



# Institute of Open and Distance Education

Faculty of Management

## Management Science

Management Science



2MBA2



**Dr. C.V. Raman University**  
Kargi Road, Kota, BILASPUR, (C. G.),  
Ph. : +07753-253801, +07753-253872  
E-mail : info@cvru.ac.in | Website : www.cvru.ac.in



# DR. C.V. RAMAN UNIVERSITY

Chhattisgarh, Bilaspur

A STATUTORY UNIVERSITY UNDER SECTION 2(F) OF THE UGC ACT

**2MBA2**

**Management Science**

**©EDMBOCIII**

2MBA2, Management science

Edition: March 2024

Compiled, reviewed and edited by Subject Expert team of University

1. Dr. Niket Shukla

(Professor, Dr. C. V. Raman University)

2. Dr. Priyank Mishra

(Associate Professor, Dr. C. V. Raman University)

3. Dr. Anshul Shrivastava

(Assistant Professor, Dr. C. V. Raman University)

Warning:

All rights reserved, No part of this publication may be reproduced or transmitted or utilized or stored in any form or by any means now known or hereinafter invented, electronic, digital or mechanical, including photocopying, scanning, recording or by any information storage or retrieval system, without prior written permission from the publisher.

Published by:

Dr. C.V. Raman University

Kargi Road, Kota, BILASPUR, (C. G.),

Ph. +07753-253801, 07753-253872

E-mail: info@cvru.ac.in

Website: [www.cvru.ac.in](http://www.cvru.ac.in)

# CONTENTS

	<b>Page No.</b>
<b>Chapter 1</b> Management Systems and Process	1
<b>Chapter 2</b> Evolution of Management Thoughts	21
<b>Chapter 3</b> Managerial Skills	66
<b>Chapter 4</b> Managerial Planning	79
<b>Chapter 5</b> Organizing and Organizational Structure Line and Staff Conflicts	100
<b>Chapter 6</b> Authority and Organisational Relationship	142





# C H A P T E R

# 1

## MANAGEMENT SYSTEMS AND PROCESS

### LEARNING OBJECTIVES

1. Definition of Management
2. Nature of Management
3. Management – A science and an Art
4. Management – An Emerging Profession
5. Management vs Administration
6. Functions of Management
7. Significance of Management

### Introduction

Management is applicable everywhere and has become the key to success in the modern world. Every organization requires making of decisions, coordination of activities, handling of people and control of operation directed towards its objectives. Numerous activities have their specific types of management problems and are discussed under such headings as farm management, management of health delivery systems, school management, public enterprise management, marketing management, production or operations management and others. All have certain elements in common. This book summarizes some of the essential concepts and techniques of management that are fundamental to various applications.

Change is an important feature of modern organizations which are managed as open systems. Significant changes take place frequently in the economic, technological, political and social environment of modern organizations. In order to keep pace with these changes, every organization requires information from the external environment and ensure healthy organization-environment interface. Certain recent changes such as revolution in information technology, liberalization of economy, trend towards globalization of economy, growth of multinational corporations, etc., have altered the relative opportunities for managers. To achieve success in managing, a manager must have a thorough knowledge of management concepts, principles and techniques and possess skills to deal with the environmental forces effectively.

### Definition of Management

It is very difficult to give a precise meaning of the term 'Management'. In the management literature, we find a large number of definitions of management given by different authors. However, the different viewpoints may be classified into the following categories, namely:

- (i) Management as an art of getting things done.
- (ii) Management as a process.

- (iii) Management as a group of managers.
- (iv) Management as a discipline

### **Management as an Art of Getting Things Done**

Mary Parker Follet defined management as “the art of getting things done through others”. This definition emphasizes that the managers achieve organizational objectives by getting work done through the workers. It represents the traditional view of management under which workers are treated as a factor of production only. This definition is incomplete in the present context. Its deficiencies are as follows:

- (1) This definition is vague as it does not identify the functions which a manager has to perform to get results from others.
- (2) It gives the impression of the manipulative character of the practice of management.
- (3) The employees are merely treated as means for getting results. In other words, their position is like a cog in the wheel. This definition ignores the needs of the workers and does not offer them human treatments.

The concept of getting things done through others further depicts that management is a sort of ‘one-way’ traffic. The workers are supposed to do whatever they are told and they have no say in the organization. Such a view cannot be accepted, particularly when the employees are educated and have faith in democracy. Therefore, the employees should not be treated as mere commodity or means to achieve certain ends. Their needs and aspirations should be given proper consideration. They must be satisfied to ensure their maximum contribution for the realization of organizational objectives.

Thus, management is certainly more than just getting things done through others. It may be viewed as a technique of getting things done through others by satisfying their needs and providing them opportunities for growth and advancement. It is appropriate to quote Harold Koontz who defined management as “the art of getting things done through and with people in formally organized groups. It is the art of creating an environment in which people can perform as individuals and yet cooperate towards attainment of group goals”. Further, managing involves certain functions such as planning, organization, staffing, leading and controlling.

### **Management as a Process**

According to McFarland, “Management is that process by which managers create, direct, maintain and operate purposive organizations through systematic, coordinated and cooperative human effort”. This definition gives us an idea about what the managers do, though it does not lay down the exact nomenclatures of the various functions of management.

Henri Fayol viewed management as a process consisting of five functions which every manager performs. “To manage is to forecast and plan, to organise, to command, to coordinate, and to control”. However, modern authors do not view coordination as a separate function of management. They consider it as the essence of managing.

The process of management involves the determination of objectives and putting them into action. In the words of George R. Terry, “Management is a distinct process consisting of activities of planning, organizing, actuating and controlling, performed to determine and accomplish stated objectives with the use of human beings and other resources”. This definition clearly identifies four functions of management.

But modern trend is to classify managerial functions into five categories, viz., (i) planning, (ii) organizing, (iii) staffing, (iv) directing (actuation or leading) and (v) controlling. As shown in Figure 1, the six Ms, i.e., men and women (human resources), materials, machines, methods, money (capital) and markets are utilized by the management to produce the goods and services desired by the society.

**The elements or functions of management are stated as follows:**

- (i) **Planning:** It means determining the objectives of the unit or activity. It also involves deciding in advance as to what is to be done, how and when.
- (ii) **Organizing:** It refers to identification of activities to be carried out, grouping of similar activities and creation of departments. Organization also leads to creation of authority and responsibility relationships throughout the enterprise.
- (iii) **Staffing:** It involves manpower planning, employment of personnel and their training, appraisal, remuneration, etc.
- (iv) **Directing:** It is a very broad function concerned with the interpersonal relations. It includes communication with subordinates, providing them leadership and also motivating them.
- (v) **Controlling:** It refers to comparing the actual performance with the plans or standards. Corrective steps are taken when the actual performance is not up to the mark.

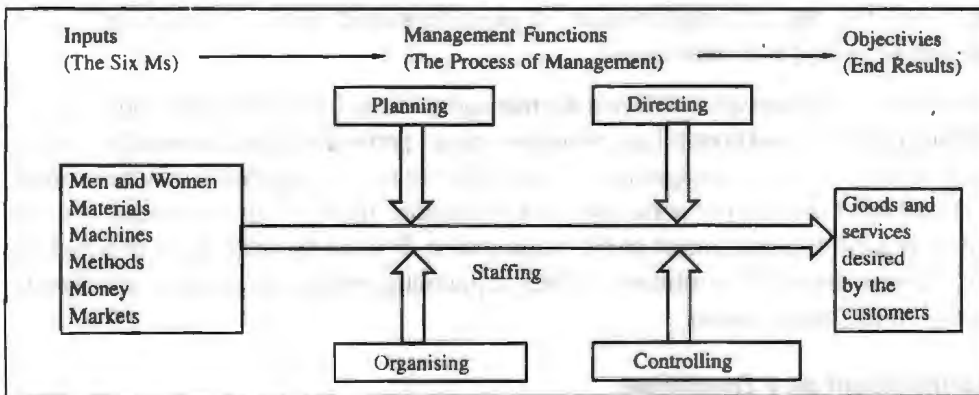

**Figure 1: The management process**

**Why is Management called a Process**

Management is called a process because it comprises a series of functions that lead to the achievement of certain objectives. As shown in Figure 2, it is a continuous process consisting of planning, organizing, staffing, directing and controlling. When a

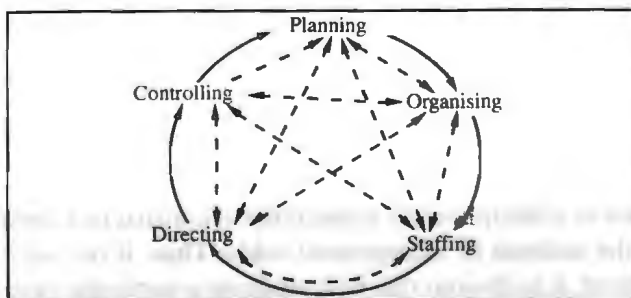

**Figure 2: Management as a continuous process**



manager reaches the last step, viz., control, his job does not end here. He will again start with planning on the basis of his observations and experience and his projection about the future. One can't say that a manager will organise only when the job of planning is over or will direct only when the stage of organizing is complete. In practice, a manager has to perform these functions simultaneously to achieve the desired objectives. Thus, management is a never-ending process.

As a process, management has two broad features:

- (i) **Management as a Continuous Process:** It does not stop anywhere. When a manager reaches the last step, viz., control, his job does not end here. Actually, he will again start with planning on the basis of his past observations and experience alongwith his projection about the future.
- (ii) **The Functions of Management are Interdependent and Interrelated:** There is an interaction between the functions as shown by dotted arrows in Figure 2. Moreover, in actual practice, there is no rigid sequence of the functions of management. Every manager has to perform these functions simultaneously to achieve the objectives of his unit.

### **Management as a Group of Managers**

The term 'management' is frequently used to denote a group of managerial personnel. When one says that 'management of this company is very efficient', it is implied that the persons who are looking after the affairs of the company are very efficient. Thus, management is the body or group of people which performs certain managerial functions for the accomplishment of predetermined goals. These people are individually known as 'managers'.

A manager is a person who performs the managerial functions of planning, organizing, staffing, directing, and controlling. Since a manager performs the managerial functions, he is a member of the management. Used in this sense, management may be termed as the group of managerial personnel. But in practice, the term 'management' is used to denote the top management of the organization. It is the top management which is concerned with goal determination, strategic planning, policy formulation and overall control of the organization.

### **Management as a Discipline**

Management has been widely recognized as a discipline or field of study. It is taught as a specialized branch of knowledge in educational institutions. As a field of study, the subject includes management concepts, principles, techniques and skills. Management is a multi-disciplinary discipline. It has drawn heavily from Anthropology, Psychology, Sociology, etc. After obtaining a diploma or degree in management, a person can try for a managerial job.

Management is both an art and a science. The knowledge, skills, techniques and principles which managers use in managing are broadly referred to as the 'fields of management'. It is regarded as an art because the performance of managerial functions requires certain skills which are a personal possession. Management is recognized as a science because it has developed certain principles, generalizations and techniques which have more or less universal application. That is why, it is taught in universities and other institutions as a discipline. As a discipline, it consists of a specific body of knowledge which the students of management study. Thus, if one says that he is a student of management, it is obvious that he is studying a particular field of learning.

## Nature of Management

Management is a distinct activity having the following salient features or characteristics:

1. **Economic Resource:** Management is an important economic resource together with land, labour and capital. As industrialization grows, the need for managers increases. Efficient management is the most critical input in the success of any organized group activity as it is the force which assembles and integrates other factors of production, namely, labour, capital and materials. Inputs of labour, capital and materials do not by themselves ensure production, they require the catalyst of management to produce goods and services required by the society. Thus, management is an essential ingredient of an organization.
2. **Goal Oriented:** Management is a purposeful activity. It coordinates the efforts of workers to achieve the goals of the organization. The success of management is measured by the extent to which the organizational goals are achieved. It is imperative that the organizational goals must be well defined and properly understood by the managers at various levels.
3. **Distinct Process:** Management is a distinct process consisting of such functions as planning, organizing, staffing, directing, and controlling. These functions are so interwoven that it is not possible to lay down exactly the sequence of various functions or their relative significance. In essence, the process of management involves decision making and putting of decisions into practice.
4. **Integrative Force:** The essence of management is integration of human and other resources to achieve the desired objectives. All these resources are made available to those who manage. Managers apply knowledge, experience and management principles for getting the results from the workers by the use of non-human resources. Managers also seek to harmonize the individuals goals with the organizational goals for the smooth working of the organization.
5. **Intangible Force:** Management has been called an unseen force. Its presence is evidenced by the result of its efforts - orderliness, informed employees, buoyant spirit and adequate work output. Thus, feeling of management is result-oriented. One may not see with the naked eyes the functioning of management but its results are apparently known. People often remark of the effectiveness (or ineffectiveness) of management on the basis of the end results, although, they can't observe it during operation.
6. **Results through Others:** The managers cannot do everything themselves. They must have the necessary ability and skills to get work accomplished through the efforts of others. They must motivate the subordinates for the accomplishment of the tasks assigned to them.
7. **A Science and an Art:** Management has an organized body of knowledge consisting of well defined concepts, principles and techniques which have wide applications. So it is treated as a science. The application of these concepts, principles and techniques requires specialized knowledge and skills on the part of the manager. Since the skills acquired by a manager are his personal possession, management is viewed as an art.
8. **System of Authority:** Management as a team of managers represents a system of authority or a hierarchy of command and control. Managers at different levels possess varying degrees of authority which gets gradually reduced as you go

down in the hierarchy. Authority enables the managers to perform their functions effectively.

9. **Multidisciplinary Subject:** Management has grown as a field of study (i.e., discipline) taking the help of so many other disciplines such as Engineering, Anthropology, Sociology and Psychology. Much of the management literature is the result of the association of these disciplines. For instance, productivity orientation drew its inspiration from Industrial Engineering and human relations orientation from Psychology. Similarly, Sociology and Operations Research have also contributed to the development of management science.
10. **Universal Application:** Management is universal in character. The principles and techniques of management are equally applicable in the fields of business, education, military, government and hospital. Henri Fayol suggested that principles are working guidelines which are flexible and capable of adaptation by every organization where the efforts of human beings are to be coordinated.

## Management – A science and an Art

Management has come to be recognized as a science recently. Prior to this, the knowledge of the practices of management was not systematically organized and experience was the only way to acquire the skills of managing. But now management has been given the shape of an organized body of knowledge by the management practitioners and scholars. This organized body of knowledge has its own distinct boundaries and fields of activity. Its study helps in gaining a rational approach to the development of means for accomplishing certain goals. That is why, management is called a science.

### As a Science

Science is a systematically organized body of knowledge based on proper findings and exact principles and is capable of verification. It is a reservoir of fundamental truths and its findings apply safely in all the situations. The generalizations are made on the basis of empirical studies and so they may be applicable in future also. Any subject which is scientifically developed and consists a subject should have the following characteristics:

- (i) It should have a systematized body of knowledge including concepts, principles and theories.
- (ii) It should have a method of scientific enquiry.
- (iii) It should establish cause and effect relationships.
- (iv) Its principles should be verifiable.
- (v) It should ensure predictable results.
- (vi) It should have universal application.

It can't be denied that management has a systematized body of knowledge pertaining to its field. But management is not as exact a science as other physical science like Astronomy, Physics, Chemistry, Biology, etc., are. The main reason for the inexactness of science of management is that it deals with the people and it is very difficult to predict their behaviour accurately. Since it is a social process, it falls in the area of "Social Sciences". Management is a universal phenomenon, but its theories and principles may produce different results in different situations. Management is a

behavioural science. Its principles and theories are situation bound because of which their applicability does not necessarily lead to the same results every time. That is why, Earnest Dale has called management a 'soft' science.

### As an Art

Art is the bringing about a desired result through the application of skills. It is concerned with the application of knowledge and skills. If a science is learnt, an art is practised. Stated differently, science is to seek knowledge and art is to apply knowledge. Thus, an art has the following features:

- (i) It denotes personal skills in a particular field of human activity.
- (ii) It signifies practical knowledge.
- (iii) It helps in achieving concrete results.
- (iv) It is creative in nature.

Every manager has to apply certain knowledge and skills while dealing with the people to achieve the desired results. Management is one of the most creative arts as it requires a vast knowledge and certain innovating, initiating, implementing and integrating skills in relation to goals, resources, techniques and results. Welding and moulding the behaviour of people at work towards achievement of certain goals in a changing environment is an art of the highest order. As an art, management calls for a corpus of abilities, skills and judgement and a continuous practice of management concepts and principles.

A manager is an artist because he applies the knowledge gained from the study of science of management for managing human and other resources. A person cannot be called a manager if he does not have the skills to apply the knowledge of management. Thus, managing does involve the use of know-how and skills for the achievement of concrete results. Like any art, management is creative in the sense that managers create new concepts and practices for further improvement. The creative managers make things happen.

From the above discussion, we can say that management is both a science and an art. It is considered a science because it has an organized body of knowledge which contains certain universal truths. It is also called an art because managing requires certain skills which are the personal possession of the managers.

Science provides the knowledge about certain things and art teaches to do certain things by the application of knowledge and skills. For instance, a medical doctor acquires the knowledge in chemistry, biology and anatomy, but the knowledge does not make him a good physician. He has to apply his knowledge intelligently. His skill in perceiving how and when to use his knowledge is very important to make him a good physician. Similarly, a manager to be successful must acquire the knowledge of science of management and also learn to apply this knowledge. A manager should be an applied scientist. He should possess not only specialized knowledge of management, but also the skill to put his knowledge into practice. Just as a doctor uses his knowledge to cure his patients, a manager should use his knowledge to solve the problems in managing men, materials, machines, methods and money.

It has been aptly remarked that management is the oldest of arts and youngest of sciences. Management is as old as the civilization. But its emergence as a scientific field of enquiry is comparatively new.



## Management – An Emerging Profession

The professionals enjoy high status in every society. Individuals desire to join a profession like medicine, chartered accountant, engineering and law. There has been a growing trend towards professionalisation of management, primarily, because of the desire of business leaders for social status and recognition.

A profession may be defined as an occupation backed by specialized knowledge and training, whose code of conduct is regulated by a professional body and which is duly recognized by the society. The basic requirements of a profession are as follows:

1. **Knowledge:** A substantial and expanding body of knowledge and information in the concerned field.
2. **Competent Application:** Skilled and judicious utilization of knowledge in the solution of complex and important problems. This requires education and training in the specified field.
3. **Professional Body:** Regulation of entry into the profession and conduct of members by the representative body.
4. **Self Control:** An established code of conduct enforced by the profession's membership.
5. **Social Responsibility:** Primarily motivated by the desire to serve others and the community.
6. **Community Approval:** Recognition of professional status by the society.

**Does management satisfy the tests of a profession?** The application of the above tests or criteria to management is examined below:

- (i) **Specialized Knowledge:** There exists a rapid expanding body of knowledge underlying the field of management. Since the beginning of this century, many thinkers on management have contributed to the field of management. Now we have systematic body of knowledge that can be used for the development of managers. Management is widely taught in the universities and other educational institutions as a discipline.
- (ii) **Competent Application–Education and Training:** MBAs are generally preferred for managerial jobs, though MBA degree is not necessary to enter this profession. Persons with degree in psychology, engineering, etc., can also take up managerial jobs. Thus, there are no standard qualifications for managers.
- (iii) **Managerial Skills can't be Learnt by Trial and Error Method:** To be a successful manager, it is essential to acquire management skills through formal education and training. Many institutes of management have been functioning in India and other countries which offer MBA and other courses in management.
- (iv) **Professional Body:** For the regulation of any profession, the existence of a representative body is a must. For example, the Institute of Chartered Accountants of India lays down the standards of education and training for those who want to enter the accounting profession. Some organizations such as the Indian Management Association and the All India Management Association have been set up in India. But none of these have any legal authority to prescribe minimum qualifications for taking up managerial posts or to regulate the conduct

of managers as is the case with the Medical Council of India and Bar Council of India.

- (v) **Self-Control or Code of Conduct:** Every profession must have a code of conduct which prescribes norms of professional ethics for its members. But there is no universally accepted code of conduct for the practising managers. The All India Management Association has prescribed a code for managers, but it has no power to take action against any manager who does not follow this code.
- (vi) **Social Responsibility:** Managers of today recognize their social responsibilities towards customers, workers and other groups. Their actions are influenced by social norms and values. That is why, managers enjoy a respectable position in the society as is the case with doctors, chartered accountants, etc.
- (vii) **Society's Approval:** The managers of modern organizations enjoy respect in the society. There is typically a positive correlation between a manager's rank and his status in the organization where he is working. This status tends to affect the manager's status outside the organization. Thus, community approves management as a profession.

It seems presumptuous to classify management as a profession. By all the benchmarks, the professionalisation of management is still far from complete. It meets the above criteria of a profession only partially as discussed below:

- (i) Though management has a well defined body of knowledge, it is difficult to say whether management meets the criterion of competent application. It is not obligatory to possess specific qualifications for being appointed as a manager. But to practice law one has to be a graduate in the Laws. Similar is the position with the medical profession. Education and training in management are also getting importance day by day in the industrial world.
- (ii) There is no professional body to regulate the educational and training standards of the managers. For instance, there is Bar Council of India to regulate the legal profession. It is encouraging to note that management associations are growing fast throughout the world. It is expected that they will be able to develop norms of behaviour for the practicing managers.
- (iii) Management does not satisfy the test of self-controls as there is no central body to lay down and enforce professional standards and code of conduct for the managers. Thus, it may be concluded that management does not fulfil all the requirements of a profession. Therefore, it can't be fully recognized as a profession. However, it is moving in that direction because:
  - The field of management is supported by a well-defined body of knowledge that can be taught and learnt.
  - Management of modern organizations requires competent application of management principles, techniques and skills. Thus, there is a great need of formal education and training in management. That is why, the demand for management degrees is increasing rapidly.
  - Managers are aware of their social responsibilities towards various groups of the society. In their actions, they are guided by their social obligations rather than their personal interests.

### Student Activity 1

“Every Manager spends a part of his time in performing administrative management functions and the remaining time on operative management functions.” Support this statement elaborately and state the difference between management and administration.

### Professionalisation of Management in India

There is a strong case for professionalisation of management in India because of the following reasons:

- (i) Professionalisation will define the duties and responsibilities of managers precisely. This will help in laying down standards of education and training for future managers.
- (ii) Professionalisation would improve the quality of management education and training. More talented and dynamic young persons would be attracted to adopt management as a career.
- (iii) Professionalisation would help in regulating the conduct of professional managers. This would strengthen ethical practices by the organizations.
- (iv) Professionalisation of management would improve the status and prestige of managers. It would remove the impression that managers are interested only in maximising wealth of shareholders. They would be seen as catalyst of change in the economy.
- (v) Business environment in future will be more challenging because of technological innovations, abrupt changes in economic policies of the government, rise of multinational corporations and increasing consciousness on the part of consumers and workers. Only the professional managers would be able to meet such challenges.

Besides the above factors, two more factors have contributed to the move towards professionalisation of management in India. First, the growth of private sector has been faster than that of the business families controlling about three-fourth of the private sector. Secondly, the growth of the public sector has given an honourable place to the professional managers in the industrial enterprises run by the Government.

It has come to be realized in India that management is a key factor in the development of the economy. Social and economic transformation is taking place at a very rapid speed. The expectations of the people from the business have changed and they have found the ways to express their expectations. People and their elected representatives have made the business enterprises understand their social obligations. No business enterprise can perform its social obligations unless it is managed by professional managers. Moreover, management of industrial enterprises has become a very complex job because of a number of factors including tough competition in the market, growth of trade union movement, increase in literacy level of the worker, and increasing participation of Government in business. All these factors have given way to the professionalisation of management in our country.

Formal education and training in management is being imparted to the students at various universities and institutes. The Institute of Chartered Management Association has also been established for the benchmarking of management education and

development of future managers. The company form of business organization has gained popularity. The divorce between management and ownership of companies has increased the need for professional managers. Even the owner-managed companies and other enterprises employ professional managers because of the specialized knowledge required in managing the different areas of business like production, finance, personnel, marketing, etc. In short, it can be said that professional status for management in India is assured because it will satisfy all the elements of a profession in the future. The society has also started recognizing management as a profession.

It is a pity that management development programmes run by the so called management institutes have been very costly. Quite often, advertisements are inserted in newspapers and professional journals inviting the practising managers or executives to participate in such programmes. The fee is within the range of ₹ 20,000 to ₹ 50,000 for some programmes of four to five days which are conducted in five star hotels. Naturally, the participants are drawn from big organizations which pay for the expenses incurred by their employees in attending such programmes. It is difficult to say that the participants and their organizations are really benefited from the so called Executive Development Programmes. The 'five star culture' has evolved at the cost of the shareholders, workers and customers of big business houses in the name of professionalisation of management.

## Management vs Administration

There has been some controversy over the use of the terms 'management', 'administration' and 'organization'. At the outset, it may be pointed out that organization is a narrower term as compared to the management process. The organization function of management deals with the division of work among individuals, creation of structure of relationship in terms of authority and responsibility and laying down the channels of communication.

A debate is very often raised as to whether or not there is a difference between 'management' and 'administration'. Conflicting views by various authors have led to some confusion over the use of these terms. American authors like Ordway Tead, Shulze, Oliver Sheldon and William Spriegel considered administration as a broader activity and management as a narrower activity. But British authors like Bench and Kimball and Kimball considered management wider than administration. The latest view is that there is no distinction between the two terms. Thus, the debate over the use of the terms management and administration has given rise to three viewpoints:

1. Administration is a higher level function concerned with the determination of policies whereas management with the implementation of policies.
  2. Management is a generic term and includes administration.
  3. There is no distinction between management and administration and both the terms are used interchangeably.
1. **Administration is a Higher-Level Function:** The first viewpoint considers administration as a determinative function and management as an executive function. William Newman, William R. Spriegel, Oliver Sheldon and Ordway Tead believe that administration involves the overall setting of major objectives, determination of policies, identifying of general purpose, laying down broad programmes, major projects and so forth. Management, according to them, refers essentially to the executive function, i.e., the active direction of human efforts with a view to getting things done. Thus, it could be said that administration, by and large, is more determinative, whereas management, by and large, is essentially executive.



2. **Management is a Generic Term:** The second viewpoint regards management as a generic term including administration. According to Brech, "Management is a social process entailing responsibility for the effective and economical planning and regulation of the operation of an enterprise in fulfillment of a given purpose. Administration is that part of management which is concerned with the installation and carrying out of the procedures by which the programme is laid down and communicated and the progress of activities is regulated and checked against plans". Thus, Brech conceived administration as a part of management. Kimball and Kimball also subscribed to this view. According to these management scientists, 'management' is put at the same pedestal at which Spriegel, Oliver, Sheldon, Shulze and Ordway Tead have put 'Administration'. Thus, the first and the second viewpoints are exactly opposite to one another.
3. **Management and Administration are Synonymous Terms:** The modern viewpoint is that there is no distinction between the terms 'management' and 'administration'. Usage also provides no distinction between these terms. The term 'management' is used for higher executive functions like determination of policies, planning, organizing, directing and controlling in the business circles while the term 'administration' is used for the same set of functions in the Government circles. So there is no difference between these two terms and they are often used interchangeably.

The distinction between management and administration may be of academic interest, but in practical life this distinction seems superfluous. Even if we accept the distinction made by Sheldon or Tead, it will be very difficult to demarcate between the so-called administrative and managerial functions because the same set of persons perform these functions.

In order to do away with the controversy, we can classify management into (i) administrative management, and (ii) operative management. Administrative management is primarily concerned with laying down policies and determination of goals whereas operative management is concerned with the implementation of the policies for the achievement of goals. But both these functions, i.e., framing of policies and executing them, are performed by the same set or group of individuals known as managers.

Figure 3 shows that every manager spends a part of his time in performing administrative management functions and the remaining time on operative management functions. However, the managers who are higher up in the hierarchy devote more time on administrative functions. They are known as 'top management'. Top management devotes a major portion of its time in determination of objectives and laying down of policies. Managers at the lower levels in the hierarchy devote comparatively less time on administrative functions and they are concerned more with directing, coordinating and control functions of management for the achievement of organizational objectives. This approach of viewing the 'management' is more practical because we do not need two groups of people to discharge administrative

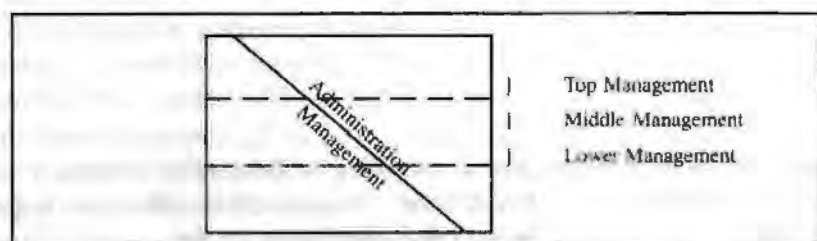

Figure 3: Management and administration

**Box 1: Difference between Management and Administration**

Basis	Management	Administration
1. Meaning	Management means getting the work done through and with others.	Administration is concerned with the formulation of objectives, plans and policies of the organisation.
2. Nature of Work	Management refers to execution of decisions. It is a doing function.	Administration relates to decision making. It is a thinking function.
3. Decision making	Management decides who shall implement the administrative decisions.	Administration determines what is to be done and when it is to be done.
4. Status	Management is relevant at lower levels of management.	Administration refers to higher levels of management.
5. Usage of Term	The term 'management' is widely used in business organisations in the private sector.	The term 'administration' is often associated with government offices, public sector and non-business organisations.

and operative management functions. In fact, every manager performs all the managerial functions though emphasis is different at various levels.

### Student Activity 2

"If you ask a manager what he does, he will most likely tell you that he plans, organizes, command, co-ordinates, and controls. Then watch what he does. Then relate what you see to these five words". Explain it elaborately.

## Functions of Management

Management of a modern business enterprise is a complex process. It is very difficult to understand the real nature of this process without studying its various facets. In the process of managing, a manager performs various functions for the achievement of pre-determined objectives. Many authorities and scholars on management have discussed the functions of management. But there is no unanimity among them about the nomenclatures of the functions of management.

It was Henri Fayol who gave for the first time a functional definition of management. According to him, "To manage is to forecast and plan, to organise, to command, to coordinate and to control". Thus, fayol analyzed the following five functions of management: (i) Forecasting and planning, (ii) Organizing, (iii) Commanding, (iv) Coordination, and (v) Control.

Ralph Davis classified managerial functions into three categories, viz., planning, organizing and control. He was of the view that command and coordination facilitate control and, therefore, should be considered as parts of it. However, some authors argue that coordination is not a separate function as it is the essence of management.

Luther Gulik coined the word 'PODSCORB' to describe the functions of management. This word is made up of the initials of following functions, namely, (i) planning, (ii) organizing, (iii) directing, (iv) staffing, (v) coordinating, (vi) reporting, and (vii) budgeting. Thus, we can say that there is no universally accepted classification of managerial functions. But at the same time, it is significant to note that though there is disagreement over the grouping and classification of management functions, there is general agreement that certain functions exist.

Joseph Massie prescribed a list of seven functions of management, namely, decision making, organizing, staffing, planning, controlling, communicating and directing. G. R. Terry described managerial functions under four heads, which are: planning, organizing, actuating, and controlling. Koontz and O'Donnell have adopted the following classification: planning, organizing, staffing, directing and controlling. They have further said, "In practice, it is not always possible to place all managerial activities neatly into these categories since the functions tend to coalesce".

The basic reason for so many classifications of functions of management is that different authors discussed them by studying different organizations. Even if we accept any one of these classifications, it should be kept in mind that these functions are not independent and they frequently overlap each other. However, for the purpose of analysis of management process, we can divide the management functions into: (1) planning, (2) organizing, (3) staffing, (4) directing and (5) controlling. These functions are briefly described below:

### **Planning**

"Planning is a mental process requiring the use of intellectual faculties, foresight and sound judgement. It is the determination of a course of action to achieve the desired result". It is the selecting and relating of facts and the making and using of assumptions regarding the future in the visualization and formation of proposed activities believed necessary to achieve desired results. It involves deciding in advance what to do, when to do it, where to do it, how to do it and who is to do it and how the results are to be evaluated. Thus, planning denotes the systematic thinking about the ways and means for the accomplishment of predetermined objectives. Goals or objectives have to be clarified first before taking any other decision. Goals provide the basis for looking into the future and for evaluating the performance with the predetermined standards.

Planning bridges the gap between where we are to where we want to be. It is a prerequisite to doing anything. Systematic planning is necessary for any business activity, otherwise it will be done in a haphazard manner. Proper planning is a must to ensure effective utilization of human and non-human resources to achieve the desired goals. It has to be done at all levels of management. The process of planning involves the following steps:

- (i) determination of goals or objectives of the enterprise
- (ii) forecasting of future environment
- (iii) search of alternative courses of action
- (iv) evaluation of various alternatives and formulation of a plan
- (v) formulation of policies and procedures
- (vi) preparation of schedules, programmes, and budgets.

### **Organizing**

Organizing is an important activity by which management brings together the human and material resources for the achievement of pre-determined objectives. Organization helps in establishing relationships among the members of the enterprise. The relationships are created in terms of authority and responsibility. Each member in the organization is assigned a specific responsibility or duty to perform and is granted the corresponding authority to perform his duty.

In the words of Louis A. Allen, "Organization involves identification and grouping the activities to be performed and dividing them among the individuals and creating authority and responsibility relationships among them for the accomplishment of organizational objectives". Thus, organizing involves the determination of activities to be performed, grouping them and assigning them to various individuals and creating a structure of authority and responsibility among the individuals to achieve the organizational goals. Organization involves the following steps:

- (i) Identification of activities required for the achievement of objectives and implementation of plans.
- (ii) Grouping of activities so as to create well defined jobs.
- (iii) Assignment of jobs to employees.
- (iv) Delegation of authority to subordinates.
- (v) Establishment of authority-responsibility relationships through out the organization.

### Staffing

The staffing function of management pertains to recruitment, selection, training, development, and appraisal of personnel. There is a controversy whether staffing is a function of every manager in the organization as there is a specializing personnel department in every organization. Since every manager is concerned with management of human resources, he must perform the staffing function. In fact, every manager is associated with the employment, training and appraisal of human resources. The personnel department is set up to provide the necessary help to managers in performing their staffing or personnel function efficiently.

Some authors do not view staffing as a separate function of management. They argue that it is part of organizing since it involves manning the positions created by organization process. It is also viewed by some as a part of direction as staffing activities are closely related to leadership, communication and motivation. However, in this book, staffing has been taken as a distinct function in view of the need to employ right type of people and to train and develop them for the well-being of the organization.

### Directing

The term 'directing' or 'direction' is generally used in every walk of life. It has got a wide interpretation these days. It is no more restricted to 'commanding' as viewed by Henri Fayol. In the words of Marshall, "Directing involves determining the course, giving orders and instructions and providing dynamic leadership". It relates to those activities which deal directly with influencing, guiding, supervising and motivating subordinates in their jobs. Thus, this function does not cease with mere issuance of directives. According to G.R. Terry, "Directing means moving to action and supplying stimulative power to group of persons". Thus, directing involves issuing instructions (or communication) to the subordinates, guiding, motivating and supervising them. These sub-functions of directing are discussed below:

- (a) **Communication:** Communication is the process of passing information and understanding from one person to another. This process is necessary for making the subordinates understand what the management expects from them. A manager has always to tell the subordinates what to do, how to do it and when to do it. He has to create an understanding in their minds with regard to these things. Communication is a two-way process. A manager to be successful must



develop an effective system of communication so that he may issue instructions, receive the reactions of the subordinates, and guide and motivate them.

- (b) **Leadership:** A manager must perform the function of leadership if he is to guide the people effectively for the achievement of organizational objectives. Leadership may be defined as the process by which a manager guides and influences the behaviour of his subordinates. A manager must possess the leadership qualities if he has to get others to follow him and accept his directions. He should also build up confidence and zeal to work along with the subordinates.
- (c) **Motivation:** A manager can get the desired results from the people working in the organization through proper stimulation or motivation. Motivation means inspiring the subordinates with a zeal to do work for the accomplishment of organizational objectives. Motivation of subordinates is necessary for getting voluntary cooperation of the subordinates. Different people are motivated by different types of rewards. The manager should study the behaviour of individuals working under him to provide them proper inducements. To some financial incentives are important while others are motivated by nonpecuniary incentives like job security, job enlargement, freedom to work and recognition by peers and management.

### Controlling

The function of controlling deals with the measurement and correction of the performance of subordinates against the pre-determined standards. E.F.L. Brech defined control as the process of checking actual performance against the agreed standards with a view to ensuring satisfactory performance. Fayol viewed control as verifying whether everything occurs in conformity with the plans adopted, the instructions issued and principles established. Controlling leads to taking corrective action if the results do not conform to plans.

The process of control involves the following steps:

- (i) **Establishment of Standards:** The management must establish standards with which the actual performance of the subordinates will be compared. The standards of performance should be laid down in unambiguous terms and should be understood by everyone in the establishment.
- (ii) **Measurement of Performance:** The actual performance of each unit and employee has to be measured in terms of quantity, quality, cost and time.
- (iii) **Appraisal of Performance:** The establishment of standards has no meaning unless they are used in actual practice. The management must provide for comparing the actual performance with the pre-established standards. The deviations from the standards should be recorded and brought to the knowledge of the management.
- (iv) **Taking Corrective Action:** When the deviations from the standards are reported to the management, it must take corrective action so that such deviations do not occur again. While taking corrective steps, management should also consider the improvement of plans and standards.

### Significance of Management

There is no substitute for management in modern organizations. As remarked by Peter F. Drucker, "Management is the dynamic, life-giving element in every business. Without it the resources of production remain resources and never become production".

An organization may have raw materials, machines, human resources and other factors, but these can't produce want satisfying products unless they are efficiently managed. Managers act as catalyst to make productive use of various resources for the accomplishment of organizational objectives.

Managing is an essential activity in every sphere of organized activity. The efficient management of human and physical resources is essential for the achievement of objectives of any group. Management pervades virtually every aspect of organized life. It is a process of taking certain decisions and putting them into action.

Both these activities, i.e. deciding and doing, are very important in every field of life. The significance of management will be more clear by going through the following points:

1. **Determination of Objectives:** The objectives of any organization are determined by the management. They are put into writing and communicated to all employees in the organization. No organization can succeed in its mission unless its objectives are identified and well defined.
2. **Achievement of Objectives:** Management is an important force for the accomplishment of the objectives of any group. The perfect coordination and integration of human and non-human resources is brought about by the management or the individuals known as 'managers'. Managers reconcile the objectives of the enterprise and those of the individuals comprising it. They direct and coordinate the activities of individuals in the use of physical resources for the achievement of pre-determined goals.

Efficient management provides leadership to the business and helps in achieving its objectives. Managing is no more restricted to the mere exercise of authority; it also involves scientific thinking, deciding and thoughtful organization, direction and control to ensure better results.

3. **Efficient Use of Resources:** The role of professional managers has increased these days. They can ensure the efficient use of various resources and increase the productivity of the enterprise. Thus, expert managers can lead the business towards growth and prosperity.
4. **Coordinated Human Efforts:** Management provides leadership and guidance to the workers. It also motivates them with the help of various incentive schemes. It reconciles their personal interests with the organizational objectives. This leads to better coordination among the human resources. This will improve the productivity of the organization.
5. **Meeting Challenges:** Management is the brain of any enterprise. All the policy decision are taken by it. Management keeps itself in touch with the current environment and supplies foresight to the enterprise. It helps in predicting what is going to happen in future which will influence the working of the enterprise. It also takes steps to ensure that the enterprise is able to meet the demands of changing environment.
6. **Economic Development:** According to Peter Drucker, "Management is the crucial factor in economic and social development". The experience of India fully illustrates Drucker's viewpoint. Indian economic history prior to her independence clearly reveals that there was no lack of human and material resources in India, but certainly there was lack of managerial personnel who could exploit the material resources with the help of human resources.

The development of country is virtually dependent upon the quality of management of its resources. It is only efficient management which enables the developing nations to make better use of material and human resources for economic development. In fact, management is "the single most critical social activity in connection with economic progress. Physical, financial and manpower resources are by themselves only passive agents; they must be effectively combined and coordinated through sound and effective management if a country is to experience a substantial level of economic growth and development. A country can have sizeable natural and manpower resources including plentiful skilled labour and substantial capital but still be relatively poor because very few competent managers are available to put these resources efficiently together in the production and distribution of useful goods and services". In short, it can be said that management is the mover and development is a consequence.

## Summary

It is very important to understand the systems framework in which an organization operates. It is very useful concept for the understanding of business operations by identifying the critical sub-systems, their inter-linkages and inter-dependence for the achievement of common objectives. The basic processes common to every management situation are those of planning, organizing, staffing, directing, and controlling. All these managerial functions are very important for the success of any organization. They all are inter-dependent and inter-related. Managers must learn the art of using these functions to their advantage to attain the objectives of the organization.

## Keywords

**Management:** The art of getting things done.

**Planning:** Determining the objectives of the unit or activity.

**Organizing:** Refers to identification of activities to be carried out, grouping of similar activities and creation of departments.

**Staffing:** Recruitment, selection, training, development and appraisal of personnel.

**Directing:** involves determining the course, giving orders and instruction and providing dynamic leadership.

**Controlling:** It deals with the measurement and correction of the performance of subordinates against the pre-determined standards.

**Process:** A series of functions that lead to the achievement of certain objectives.

**Economic Resource:** Management, land, labour and capital.

**Goal-oriented:** Purposeful activity towards achieving the goals of the organization.

**Science:** A systematically organized body of knowledge including concepts, principles and theories.

**Art:** It is the bringing about a desired results through the application of skills.

**Code of conduct:** It prescribed the norms of professional ethics for its members.

**Professionalisation:** It means defining the duties and responsibilities of the managers to improve the quality of management education and training.

**Administration:** It is a higher-level function concerned with the determination of policies.

**Top management:** Managers who are higher up in the hierarchy devoting more time on administrative functions.

## Review Questions

1. "Management is getting things done through other people". Is this definition adequate for the present day concept of management? Discuss fully.
2. "Management is the force which leads, guides and directs an organization in the accomplishment of pre-determined objectives". Discuss and give suitable definition of management.
3. Explain the features that determine the nature of management.
4. There are many definitions of management which emphasise one or the other important aspect of management. Discuss and give various characteristics of management.
5. "Management is the effective utilization of human and material resources to achieve the enterprise's objectives". Comment.
6. Is management a profession? Give arguments for your answer.
7. Clearly explain the concept and significance of management. Distinguish between management and administration.
8. Discuss the nature and scope of management. Is management a science or an art or both?
9. "Management is not a profession but is heading towards that direction". Do you agree with this statement? Give reasons in support of your answer.
10. "Management is the art of getting things done through people". Comment.
11. Describe the process of management and explain how it can be used to accomplish results in any organization?
12. Distinguish between management and administration.
13. Explain the concept of management. Review in brief the main functions of management.
14. What are the functions of a manager? Is mere knowledge of management enough to become a successful manager?
15. 'To manage is to forecast and plan, to organise, to command, to coordinate and to control'. Discuss the statement.
16. Name the various functions which constitute the process of management and discuss each of them briefly.
17. "All organizations need management". Comment.
18. Discuss clearly the significance of management from the point of view of modern business operations
19. Answer the following:
  - (a) Enumerate the elements of management process.
  - (b) Why is management called a science?
  - (c) Distinguish between management and administration.

## Further Readings

Brech, E.F.L., *Management., Its Nature and Significance.* Sir Isaac Pitman & Sons, Ltd.

Farmer, R.N. and Richman, B.M., *Comparative Management and Economic Progress,* Richard D. Irwin Inc., Homewood, Illinois.

Harold Koontz and Cyril O'Donnell, *Management,* Mc-Graw-Hill Kogakusha, Ltd.

Henri Fayol, *General and Industrial Administration,* Sir Isaac Pitman & Sons.

Marshall E. Dimock, *A Philosophy of Administration,* Harper and Row.

McFarland, Dalton E., *Management Foundations and Practices.* The Macmillan Co.

Paul E. Torgersen and Irwin T. Weinstock, *Management – An Integrated Approach.*

Peter F. Drucker, *Management: Tasks, Responsibilities and Practices.* Heinemann.

Sheldon Oliver, *The Philosophy of Management,* Sir Isaac Pitman and Sons, Ltd.

Spiegel, William R., *Principles of Business Organization and Operation,* Prentice-Hall.

Terry, George R., *Principles of Management,* Richard, D. Irwin, Inc., Homewood, Illinois.

## C H A P T E R

# 2

## EVOLUTION OF MANAGEMENT THOUGHTS

### LEARNING OBJECTIVES

1. Approaches to Management
2. Classical Theory
3. Scientific Management Approach
4. Management Process or Administrative Management Approach
5. Bureaucracy
6. Neo-Classical Theory
7. Behavioural Science Approach
8. Quantitative Approach
9. Linear Programming
10. PERT and CPM
11. Game Theory
12. Systems Approach
13. Contingency Approach
14. Operational Approach
15. Leading Management Thinkers

### Introduction

The origin of management can be traced back to the days when man started living in groups. One can argue that management took the form of leadership which was essential to coordinate the efforts of the group members in order to arrange the necessities of life. History reveals that strong men organized the masses into groups according to their intelligence, physical and mental capabilities. According to Egyptian literature of 1300 B.C., the art of management was being practiced in different forms by different people. The literature clearly indicates the recognition of the importance of organization and administration in the bureaucratic set up. Similar records exist for ancient China. According to L.S. Hsu, Confucius's parables include practical suggestions for proper public administration and admonitions to choose honest, unselfish and capable public officers.

In Greece, the existence of the Athenian commonwealth, with its councils, courts, administrators and board of general indicates the nature of management. Similarly, in Rome, the existence of Roman magistrates, with their functional areas of authority and degree of importance, indicates a scalar relationship characteristic of organization. It is believed that the secret of the success of the Roman Empire lay in the ability of Romans to organise. Through the use of the scalar principle and the delegation of authority, the city of Rome was expanded to an efficient empire.



## Approaches to Management

### *(Schools of Management Thought)*

The growth of modern management techniques began with the industrial revolution in England during the 18th and 19th centuries. A series of inventions were made by the scientists like Hargreaves, Arkwright, Crompton, Kay and Cartwright. The important inventions include "Spinning jenny", "Water frame", "Mule", "Power loom" and "Machine lathe", which completely revolutionized the commerce and industry. These led to production on large scale and introduction of division of labour. Soon joint stock companies came into being which separated the ownership and management functions. There was a great need of persons who could manage big industrial enterprises.

The above development led to the emergence to different schools of thought of management. The divergent directions of management though have caused one management writer, Harold Kootz, to call the resulting array "the management theory jungle". However, for an easier understanding of the development of management thought, we can classify the different schools of management thought as follows:

1. Classical theory:
  - (a) Scientific Management Approach.
  - (b) Management Process of Administrative Management Approach.
  - (c) Bureaucratic Organization Approach.
2. Neo-classical or Human Relations Approach.
3. Behavioural Science Approach.
4. Quantitative or Management Science Approach.
5. Systems Approach.
6. Contingency Approach.
7. Operational Approach.

Classical and neo-classical approaches constitute the 'traditional schools of management thought' and the other approaches are often termed as 'modern approaches'. These approaches are briefly discussed below:

### **Classical theory**

The classical theory represents the traditionally accepted views about organizations. In a way, it signifies the beginning of the systematic study of organizations. That is why, it is said to be the oldest school of thought about organization and their management. The classical theorists concentrated on organization structure for the achievement of organizational goals and also developed certain principles of management. Many of the classical concepts and principles hold good even today. The classical thought can be studied under three streams, namely, (a) Scientific Management, (b) Administrative Management or Management Process, and (c) Bureaucracy.

F.W. Taylor insisted on application of scientific methods to the problem of management. His focus was on division of labour, fixing everybody's work for the day and functional foremanship. That is why, Taylor's scientific management has been referred to as "machine theory". It may be noted that scientific management group emphasized efficiency of lower levels of organization. It was Henri Fayol who showed concern

for efficiency at the higher levels for the first time. Fayol who showed concern for efficiency at the higher levels for the first time. Fayol gave fourteen principles of management which he thought are universally applicable. Max Weber introduced 'bureaucracy' as a form of rational organization. It is characterized by division of labour, specialization, structure, impersonal relations, competence of personnel, etc.

### **Neo-Classical Theory or Human Relations Approach**

The neo-classical writers tried to remove the deficiencies of the classical school and suggested recognition of the need of good human relations in the organization. Their propositions are based on 'human relations studies' conducted at the Hawthorne Plant of General Electricals, U.S.A. That is why, they are also known as 'human rationalists'.

The human relations approach revealed the importance of social and psychological factors in determining workers' productivity and satisfaction. It was instrumental in creating a new image of man and the work-place. This approach put stress on communication, interpersonal relations and informal groups at the work-palace.

### **Behavioural Science Approach**

This approach emerged as a result of the contributions of psychologists, sociologists and anthropologists to the field of management. The behavioural science perspective believes that it is difficult to understand the sociology of a group separate from the psychology of the individuals comprising it and the anthropology of the culture within which it exists. Thus, the behavioural science are transactional; they are concerned with all relevant aspect of human behaviour including the interactions among all important factors.

The behavioural science approach utilizes methods and techniques of social science such as psychology, sociology, social psychology and anthropology of the study of human behaviour. Data is objectively collected and analyzed by the social scientists to study various aspects of human behaviour. The pioneers of this school reasoned that in as much as managing involves getting things done with a through people, the study of management must be centered around people and their interpersonal relations. The behaviourists concentrated on motivation, individual drives, group relations, leadership, group dynamics and so forth.

### **Quantitative or Management Science Approach**

The quantitative or mathematical approach uses pertinent scientific tools for providing and quantitative basis for managerial decisions. The abiding belief of this approach is that management problems can be expressed in terms of mathematical symbols and relationships. The basic approach is the construction of a model because it is through this device that the problem is expressed in its basic relationships and in terms of selected objectives. The users of such models are known as management scientists.

The techniques commonly used for managerial decision-making include Linear Programming, Critical Path Method (CPM), Programmes Evaluation Review Technique (PERT), Games Theory, Queuing Theory and Break-Even Analysis. The application of such techniques helps in solving several problems of management such as inventory control, production control, price determination, etc.

### **Systems Approach**

The systems approach is based on the generalization that an organization is an open system composed on inter-related and inter-dependent elements. This approach lays

emphasis on the parts of the system, the nature of their inter-dependency, goals set by the system and communication network in the system. Another basic feature of the system approach is that attention is paid towards the overall effectiveness of the systems rather than the effectiveness of individual subsystems. Further, an organization is an open system which has continuous interface with the environment. The systems approach lays a great emphasis on the adaptability of the system to the requirements of external environment.

### **Contingency Approach**

This approach is concerned with the analysis of interaction of specific organizations with their external environment and the adoption of structure to meet the requirements of the situation. Underlying idea of this approach is that the internal functioning of organizations must be consistent with the demands of technology and external environment if the organization is to be effective. This approach suggests that there is no one best way to handle any of the management problems and there is no best organizational structure to suit all situations. The application of management principles and practices should be contingent upon the existing circumstances. Functional, behaviour, quantitative and systems approaches should be applied situationally. The organization structure should be so designed that it enables the organization to have healthy interaction with external environment.

### **Operational approach**

Operational approach regards management as a universally applicable body of knowledge that can be brought to bear at all levels of managing and in all types of enterprises. At the same time, the approach recognizes that the actual problems managers face and the environments in which they operate may vary between enterprises and levels, and it also recognizes that application of science by a perceptive practitioner must take this into account in designing practical problem solutions.

### **Classical Theory**

The classical theory signifies the beginning of the systematic study of management organization. It is often called the traditional theory. It can be traced historically to the 19th century prototype industrial and military organizations. Several writers contributed to the classical thought in the early years of the 20th century. They include Taylor, Fayol, Weber, Luther Gulick, Urwick, Mooney and Reiley and many others.

The classical writers thought of the organization in terms of its purpose and formal structure. They placed emphasis on the planning of work, the technical requirements of the organization, principles of management, and the assumption of rational and logical behaviour. Thus, the classical theorists dealt almost exclusively with the anatomy of formal organization. Organization is treated like a machine and its efficiency can be increased by making each individual working in the organization efficient. For instance, F.W. Taylor emphasized on division of labour, fixing everybody's work for the day and functional foremanship. That is why, Taylor's scientific management has been referred to as 'machine theory'

The classical theory incorporates three viewpoints: (1) Taylor's Scientific Management (2) Fayol's Administrative Management; and (3) Weber's Ideal Bureaucracy (an organization based on rules and regulations, formal relations, specialization, etc.). All the three concentrated on the structure of organization for greater efficiency. Several

other trailblazers have also contributed to the classical theory. For instance, Mooney and Reiley published 'Onward Industry' in 1931 in which they attempted to find organizational universals. Subsequently, notable contributions came from Gullick, Oliver Sheldon, Urwick and many others. All these theorists were concerned with the structure of organizations and that is why their approach is also sometimes labelled as 'structural theory of organization'. Salient features of classical approach are as follows:

- (i) The classical theory laid emphasis on division of labour and specialization, structure, scalar and functional processes and span of control. Thus, they concentrated on the anatomy of formal organization.
- (ii) The classical theorists emphasis organization structure for co-ordination of various activities. They ignored the role of human element.
- (iii) The classical theory ignored the impact of external environment on the working of the organization. Thus, it treated organizations as closed systems.
- (iv) The efficiency of the organization can be increased by making each individual efficient.
- (v) The integration of the organization is achieved through the authority and control of the central mechanism. Thus, it is based on centralization of authority.
- (vi) There is no conflict between the individuals and the organization. In case of any conflict, the interests of the organization should prevail.
- (vii) The people at work could be motivated by the economic rewards as they were supposed to be 'rational economic persons'.

### Appraisal of Classical Theory

The fundamental objections against the classical theory are discussed below:

1. **Narrow View of Organization:** The value of classical theory is limited by its narrow concentration on the anatomy of formal organization. In order to achieve rationality, the classical writers ignored the human relations aspect. The interplay of individual personality, informal groups and inter organizational conflicts in the formal organization were neglected. It is said that the focus of classical theory is on 'organization without people'.
2. **Assumption of Closed System:** Classical theorists viewed organization as a closed system, i.e., having no interaction with environment. This assumption is totally unrealistic. A modern organization is an open system which has continuous interaction with the environment through the exchange of inputs and outputs and various types of information.
3. **Assumptions about Human Behaviour:** The human being were treated like any other factor of production. They were supposed to obey their superiors. The classical writers ignored the social, psychological and motivational aspects of human behaviour.
4. **Economic Rewards as Main Motivators:** The assumption that people at work can be motivated solely through economic rewards is also wrong. Several researches in human behaviour have contradicted this assumption. Non-monetary factors like better status and job enrichment can also motivate the workers.
5. **Lack of Empirical Verification:** The classical principles are mostly based on the personal experiences and limited observations of the practitioners. They are



not based on empirical research. They lack precision and comprehensive framework for analysis. Moreover, it is not clear whether these principles are action recommendations or simply definitions.

6. ***Lack of Universality of Principles:*** Classical theorists claimed that their principles have universal application. This suggests that the same principles can be applied in : (i) different organizations, (ii) different management levels in the same organization, and (iii) different functions of the same organization. The empirical researches, however, suggest that none of the principles has such characteristics. Moreover, there are many of the principles which contradict with other principles. For example, principle of specialization is quite in conflict with the principle of unity of command.
7. ***Excessive Emphasis on Rules and Regulations:*** Weber's 'ideal' bureaucracy, a major constituent of classical theory, suggested strict adherence to rules and regulations. The scope for individual initiative is thus limited. The result is red-tapism in the organization. Observation of rules and regulations becomes the main objective while the real objectives for which these rules and regulations are formed are forgotten.

## Scientific Management Approach

The impetus for the scientific management approach came from the first industrial revolution. Because it brought about such an extraordinary mechanization of industry, this revolution necessitated the development of new management principles and practices. The main contributors to scientific management were Frederick W. Taylor, Henry L. Gantt, Frank Gilbreth, Lillian Gilbreth and Harrington Emerson.

F.W. Taylor (1865-1915) was the first person who insisted on the introduction of scientific methods in management. He launched a new movement during the last decade of 19th century which is known as 'Scientific Management'. That is why, Taylor is regarded as the father of scientific management. Taylor was an American engineer who responded to the challenges of management around the turn of the century. During that period, productivity was very low, labour became extremely dissatisfied and industries had to face frequent strikes and lockouts. Taylor's contribution was a system based on science whereby lower labour cost could be achieved simultaneously with higher wages. He suggested the change in the mental attitudes of the workers and the management to bring harmony in the industry. Along with Taylor, other contributors to the scientific management approach include Henry L. Gantt, Frank Gilbreth, Lillian Gilbreth and Harrington Emerson.

Scientific management means application of scientific methods to the problems of management. Taylor advocated scientific task setting based on time and motion study, standardization of materials, tools and working conditions, scientific selection and training of workers and so on. It is to be noted that Taylor's thinking was confined to management at the shop level. However, he demonstrated the possibility and significance of the scientific analysis of the various aspects of management. To sum up, he laid emphasis on the following principles:

1. Science, not rule of thumb.
2. Harmony in group action, rather than discord.
3. Maximum output in place of restricted output.
4. Scientific selection, training and placement of the workers.
5. Almost equal division of work and responsibility between workers and managers.

The basic idea behind the principles of scientific management is to change the mental attitudes of the workers and the management towards each other. Taylor called it 'Mental Revolution' which has three implications:

- (i) all out efforts for increase in production;
- (ii) creation of the spirit of mutual trust and confidence; and
- (iii) inculcating and developing the scientific attitude towards problems.

Taylor suggested that management should try to find the best methods of doing various jobs and introduce standardized materials, tools and equipment so that wastages are reduced. The management should select right types of people and give them adequate training so as to increase the quantity and quality of production. It must create congenial working conditions for optimum efficiency of the workers. It should perform the decision-making function and should always try to give maximum cooperation to the workers to ensure that work is done according to the scientific techniques.

The workers should also revise their attitude towards the management. They should not be work-shirkers. They should be disciplined, loyal and sincere in fulfilling the tasks assigned to them. They should not indulge in wastage of resources. Both the management and the workers should trust each other and cooperate in achieving maximum production.

Thus, Taylor stood for creating a mental revolution on the part of management and workers. It is to be noted that Taylor's thinking was confined to management at the shop level. However, he demonstrated the possibility and significance of the scientific analysis of the various aspects of management. To put the philosophy of scientific management into practice, Taylor and his associates suggested the following techniques:

- (i) Scientific task setting to determine a fair days; work.
- (ii) Work study to simplify work and increase efficiency. This involves methods study, time study and motion study.
- (iii) Standardization of materials, tools equipment, costing system, etc.
- (iv) Scientific selection and training of workers.
- (v) Differential piece-wage plan to reward the highly efficient workers.
- (vi) Specialization in planning and operations through 'functional foremanship'. Foremen in the planning department include: route clerk, instruction card clear, time and cost clerk and shop disciplinarian and those in the operations department include: gang boss, speed boss, repair boss and inspector.
- (vii) Elimination of wastes and rationalization of system of control.

## Criticism of Scientific Management

Taylor's scientific management was criticized not only by the workers and managers but also by the psychologists and the general public. The main grounds of criticism are given below:

1. The use of the word 'Scientific' before 'Management' was objected because what is actually meant by scientific management is nothing but a scientific approach to management.
2. It was argued that the principles of scientific management as advocated by a Taylor were confined mostly to production management. He ignored certain other



essential aspects of management like finance, marketing, accounting and personnel.

3. Taylor advocated the concept of functional foremanship to bring about specialization in the organization. But this is not feasible in practice as a worker can't carry out instructions from eight foremen.
4. Scientific management is production-centered as it concentrates too much on the technical aspects of work and undermines the human factor in industry. It resulted in monotony of job, loss of initiative, overspeeding workers, wage reductions, job insecurity, etc.
5. Scientific management is based upon the assumption that workers are 'rational economic beings'. They are treated as mere extensions of machines devoid of any feelings and emotions. They can be made to work through monetary incentives and exercise of authority. Scientific management, thus, ignores the social and psychological needs of workers.
6. Trade unionists regarded the principles of scientific management as the means to exploit labour because the wages of the workers were not increased in direct proportion to productivity increases.

Many of the above objections were later remedied by the other contributors to scientific management like Henri L. Gantt, Frank Gilbreth, Lillian Gilbreth and Harrington Emerson. Many of the recommendations of Taylore are still being applied by the modern business undertakings. In short, it can be said that Taylore was the pioneer in introducing scientific reasoning to the discipline of management.

### **Management Process or Administrative Management Approach**

The advocates of this school perceive management as a process involving certain functions such as planning, organizing, directing and controlling. That is why, it is also called the 'functional' approach. Henri Fayol is regarded as the father of this schools. Henri Fayol defined management in terms of certain functions and then laid down fourteen principles of management which according to him have universal applicability.

Henri Fayol was a French executive who emphasized that management could be both taught and learnt. His long practical experience is reflected in his paper, "Administration industrielle et generale" (General and Industrial Management). Fayol tried to develop a theory of management. He discussed the principles of general management and argued that managerial ability can be acquired as any other technical ability. He not only recommended formal teaching in management but also practised it by founding the Centre for Administrative Studies in Paris. Thus, he was a pioneer in the field of management education. In brief, Fayol's views on management command acceptability even today because they are much in tune with the requirements of the management in the present-day world.

Fayol began by classifying all operations in business in business organizations under the following six categories:

- (i) technical (production);
- (ii) commercial (purchases and sales);
- (iii) financial (funding and controlling capital);
- (iv) security (protection);
- (v) accounting (balance sheet, costing records); and

- (vi) administrative or managerial (planning, organizing, commanding, coordinating and controlling).

Fayol pointed out that managerial activity deserved more attention. In his view, management is the process composed of five elements or functions: planning, organizing, commanding, coordination and control. Fayol observed:

- (i) to plan means to study the future and arrange the plan of operation;
- (ii) to organise means to build up the material and human organization of the business;
- (iii) to command means to make the staff do their work;
- (iv) to coordinate means to unite all activities; and
- (v) to control means to see that everything is done in accordance with the standards that have been laid down and the instructions given.

Fayol completed his theory by stating that to be effective, management should be based on the following fourteen principles:

1. Division of work,
2. Authority and responsibility,
3. Discipline,
4. Unity of command,
5. Unity of direction,
6. Subordination of individual interest to the general interest,
7. Remuneration,
8. Centralization,
9. Scalar chain,
10. Order,
11. Equity,
12. Stability,
13. Initiative, and
14. Esprit de corps (union is strength).

It is significant to point that Fayol used the word 'principle' only for convenience. He did not consider them immutable laws. However, he thought that the principles would be useful to all types of group activity. Thus, he was a universalist in this sense. His theory of management completely revolutionized the thinking of managers as throughout his treatise, there exists an understanding of the universality of the principles. Some of these principles were amplified later on by the writers like Sheldon, Urwick, Mooney and Barnard. Oliver Sheldon wrote 'The Philosophy of Management' in which he advocated social responsibility of management. Mooney and Reiley published their views on management under the title 'The Principles of Organization'. Chester I. Barnard wrote 'The Functions of the Executive' which discusses the major functions of the manager and also lays down the importance of communication in management.

## Criticism of Process of Functional Approach

Though the proponents of management process approach have made significant contribution to the development of thought, their work suffers from the following limitations:

- (i) There is no single classification of managerial functions acceptable to all the functional theorists. There is also lack of unanimity about the various terms such as management and administration, commanding and directing, etc.
- (ii) The functionalists considered their principles to be universal in nature. But many of the principles have failed to deliver the desired results in certain situations.
- (iii) The functional theorists did not consider the external environment of business.
- (iv) Fayol overemphasized the intellectual side of management. He felt that management should be formally taught, but he did not elaborate the nature and contents of management education.

## Bureaucracy

Max Weber (1864-1920), a German sociologist contributed his views on bureaucracy to the management thought. His primary contribution includes his theory of authority structure and his description of organizations based on the nature of authority relations within them. Essentially, it was Weber's contention that there are three types of legitimate authority which are as follows:

- (1) **Rational-legal authority:** Obedience is owed to a legally established position or rank within the hierarchy of a business, military unit, government, and so on.
- (2) **Traditional authority:** People obey a person because he belongs to certain class or occupies a positions traditionally recognized as possessing authority, such as a real family.
- (3) **Charismatic authority:** Obedience is based on the followers belief that a person has some special power or appeal.

Weber's theory bureaucracy recognizes rational-legal authority as the most important type in organizations. Under traditional authority, leaders are not chosen for their competence, and charismatic authority is too emotional and irrational. A bureaucratic organization which is based on rational-legal authority display the following features:

- (i) **Division of Work:** There is a high degree of division of work at both the operative and administrative levels. This leads to specialization of work.
- (ii) **Hierarchy of Positions:** There is a hierarchy of authority in the organization. Each lower position is under the control of a higher one. Thus, there is unity of command. The bureaucratic structure is hierarchical in nature. It is like a pyramid in which quantity of authority increases as one moves up the ladder in the organization.
- (iii) **Rules and Regulations:** The rules, regulations and procedures are clearly laid down by the top administration. Their benefits are as under:
  - (a) They standardize operations and decisions.
  - (b) They serve as receptacles of past learning.
  - (c) They protect incumbents and ensure equality of treatment.

- (iv) **Impersonal Conduct:** There is impersonality of relationships among the organizational members. The decisions are entirely guided by rules and regulations and are totally impersonal. There is no room for emotions and sentiments in this type of structure.
- (v) **Staffing:** The personnel are employed by a contractual relationship between the employee and employer. The tenure of service is governed by the rules and regulations of the organization. The employees get a salary every months which is based on the job they handle and also the length of service.
- (vi) **Technical Competence:** The bureaucrats are neither elected not inherited, but they are appointed through selection and the basis of selection is their technical competence. Promotions in bureaucracies are also based on technical qualifications and performance.
- (vii) **Official Records:** The administration of a bureaucratic organization is supported by an efficient system of record-keeping. The decisions and activities of the organization are formally recorded and preserved safely for future reference This is made possible by extensive filing system. The filing system makes the organization independent of individuals. The official records serve as the memory of the organization.

Weber's ideal bureaucracy has been designed to bring rationality and predictability of behavior in organizations. It is an administrative device that can help in achieving the following advantages

- (i) There is a proper delegation of authority in the organization. People are given tasks according to their competence.
- (ii) Because of rules and regulations, all actions are taken carefully. There is consistency of actions.
- (iii) The behaviour of the employees is rational. They take decisions as per laws, rules and regulations. They don't go by their whims, emotions or prejudices.
- (iv) The behaviour of the employees is predictable. It is known how they will react under different situations as guidelines are already there in writing.
- (v) Bureaucracy leads to efficiency in the organization. There is division of work leading to specialization which results in efficiency.

### **Criticism of Bureaucracy**

Criticism is not free of flaws. It may lead to many undesirable consequences such as:

- (i) The rules may be followed in letter and not in spirit. Thus, instead of providing guidelines, the rules may become source of inefficiency. The rules may be misused or misinterpreted by the persons concerned with the implementation of rules. Red tapism and technicalism may follow as a result.
- (ii) Bureaucracy does not consider informal organization and inter-personal difficulties.
- (iii) Bureaucracy discourages innovation because every employee is supposed to act as per rules and regulations or to the secondary goals.
- (iv) Goal displacement may take place in a bureaucratic organization. The bureaucrats may give priority to rules and regulations or to the secondary goals.

- (v) The bureaucratic structure is tall consisting of several layers of executives. Thus, communication from the top level to the lowest level will take a very long time.

## **Neo-Classical Theory**

### *(Human Relations Approach)*

The classical writers including Weber, Taylor and Fayol neglected the human relations aspect. The neo-classicists focussed on the human aspect of industry. They modified the classical theory by emphasizing the fact that organization is a social system and the human factor is the most important element within it. They conducted some experiments (known as Hawthorne Experiments) and investigated informal groupings, informal relationships, patterns of communication, patterns of informal leadership, etc. This led to the development of human relations approach. Elton Mayo is generally recognized as the father of the Human Relations School. Other prominent contributors to this schools include Roethlisberger, Dickson, Dewey, Lewin, etc.

The human relations approach is concerned with recognition of the importance of human element in organizations. It revealed the importance of social and psychological factors in determining workers' productivity and satisfaction. It was instrumental in creating a new image of man and the work place. The neo-classical or human relations approach put stress on inter-personal relations and informal groups at the work-place.

The human relationists argued that achievement of organizational objectives is impossible without the willing cooperation of people and such cooperation cannot be automatically secured or ordered. It has to be consciously achieved. The neo-classical approach advocated people-oriented organization structure which will integrate both informal and formal organizations.

The basic tenets of neo-classical theory or human relations approach are as under:

- (i) The business organization is a social system.
- (ii) The behaviour of an individual is dominated by the informal group of which he is a member.
- (iii) An individual employee cannot be motivated by economic incentives alone. His social and psychological needs must be satisfied to improve the level of motivation.
- (iv) In an organization, it is ultimately cooperative attitude and not the more command which yields result.
- (v) Management must aim at developing social and leadership skills in addition to technical skills. It must take interest in the welfare of workers.
- (vi) Morale and productivity go hand in hand in an organization.

### **Hawthorne Studies**

In 1927, a group of researchers led by George Elton Mayo and Fritz J. Roethlisberger at the Harvard Business School were invited to join in the studies at the Hawthorne Works of Western Electric Company, Chicago. The experiment lasted upto 1932. Earlier, from 1924 to 1927, the National Research Council made a study in collaboration with the Western Electric Company to determine the effect of illumination and other conditions upon workers and their productivity.

- (i) ***Illumination Experiment:*** This experiment was conducted to establish relationship between output and illumination. The output tended to increase every



time as the intensity of light was improved. But the output again showed an upward trend when the illumination was brought down gradually from the normal level. Thus, it was found that there is no consistent relationship between output of workers and illumination in the factory. There were some other factors which influenced the productivity of workers when the intensity of light was increased or decreased.

- (ii) **Relay Assembly Room Experiment:** In this experiment, a small homogeneous work-group of girls was constituted. Several new elements were introduced in the work atmosphere of this group. These included shorter working hours, rest pauses, improved physical conditions, friendly and informal supervision, free social interaction among group members, etc. Productivity and morale increased considerably during the period of the experiment. Morale and productivity were maintained even if improvements in working conditions were withdrawn. The researches concluded that socio-psychological factors such as feeling of being important, recognition, attention, participation, cohesive work-group, and non-directive supervision held the key for higher productivity.
- (iii) **Bank Wiring Observation Room Experiment:** This experiment was conducted to study a group of workers under conditions which were as close as possible to normal. This group comprised of 14 workers. After the experiment, the production records of this group were compared with their earlier production records. There were no significant changes in the two because of the maintenance of 'normal conditions'. However, existence of informal cliques in the group and informal production norms were observed by the researchers.

The Bank Wiring Experiment led to the following observations:

- (1) Each individual was restricting output.
  - (2) The group had its own "unofficial" standards of performance.
  - (3) Individual output remained fairly constant over a period of time.
  - (4) Departmental records were distorted due to differences between actual and reported output or between standard and reported working time.
- (iv) **Mass Interview Programme:** The researchers interviewed a large number of workers with regard to their opinions on work, working conditions and supervision. Initially, a direct approach was used whereby interviewers asked questions considered important by managers and researchers. Later, this approach was replaced by an indirect technique where the interviewer simply listened to what the employees had to say. The findings confirmed the importance of social factors at work in the total work environment.

### Contributions of Human Relations Approach or Hawthorne Studies

The human relationists proposed the following points as a result of their findings of the Hawthorne experiments:

1. **Social System:** The organisation in general is a social system composed of numerous interacting parts. The social system defines individual roles and establishes norms that may differ from those of the formal organisation. The workers follow a social norm determined by their co-workers, which defines the proper amount of work, rather than try to achieve the targets management thinks they can achieve, even though this would have helped them to earn as much as they physically can.

2. **Social Environment:** The social environment on the job affects the workers and is also affected by them. Management is not the only variable. Social and psychological factors exercise a great influence on the behaviour of workers. Therefore, every manager should adopt a sound human approach to all organisational problems.
3. **Informal Organisation:** The informal organisation does also exist within the frame work of formal organisation and it affects and is affected by the formal organisation.
4. **Group Dynamics:** At the workplace, the workers often do not act or react as individuals but as members of groups. The group determines the norms of behaviour for the group members and thus exercises a powerful influence on the attitudes and performance of individual workers. The management should deal with workers as members of work group rather than as individuals.
5. **Informal Leader:** There is an emergence of informal leadership as against formal leadership and the informal leader sets and enforces group norms. He helps the workers to function as a social group and the formal leader is rendered ineffective unless he conforms to the norms of the group which he is supposed to be incharge.
6. **Communication:** Two-way communication is necessary because it carries necessary information downward for the proper functioning of the organisation and transmits upward the feelings and sentiments of people who work in the organisation. It will help in securing workers' cooperation and participation in the decision-making process. Workers tend to be more productive when they are given the opportunity to express their feelings, opinions and grievances. This also given them psychological satisfaction.
7. **Non-economic Rewards:** Money is only one of the motivators, but not the sole motivator of human behaviour. The social and psychological needs of the workers are very strong. So non-economic rewards such as praise, status, interpersonal relations, etc. play an important role in motivating the employees. Such rewards must be integrated with the wages and fringe benefits of the employees.
8. **Conflicts:** There may arise conflicts between the organisational goals and group goals. Conflicts will harm the interest of workers if they are not handled properly. Conflicts can be resolved through improvement of human relations in the organisation.

### Student Activity 1

1. What is the relevance of neo-classical theory over classical theory?
2. Why is neo-classical theory criticized?

### Criticism of Human Relations Approach

The human relations approach has been criticized on the following grounds:

- (i) **Lack of Scientific Validity:** The human relationists drew conclusions from Hawthorne studies. These conclusions are based on clinical insight rather than on scientific evidence. The groups chosen for study were not representative in character. The findings based upon temporary groups do not apply to groups that have continuing relationship with one another. Moreover, the experiments focussed on operative employees only.

- (ii) **Over-emphasis on Group:** The human relations approach over-emphasises the group and group decision-making. But in practice, groups may create problems for the management and collective decision-making may not be possible.
- (iii) **Over-stretching of Human Relations:** It is assumed that all organisational problems are amenable to solutions through human relations. This assumption does not hold good in practice. The satisfied workers may not be more productive workers.
- (iv) **Limited Focus on Work:** The human relations approach lacks adequate focus on work. It puts all the emphasis on interpersonal relations and on the informal group. It tends to overemphasize the psychological aspects at the cost of the structural and technical aspects.
- (v) **Over-stress on Socio-psychological Factors:** The human relations approach undermines the role of economic incentives in motivation and gives excessive stress on social and psychological factors. If the wages are too low, the employees will feel dissatisfied despite good inter-personal relations at the workplace. Thus, it may be said that the human relations approach seeks to exploit the sentiments of employees for the benefit of the organisation.
- (vi) **Conflict between Organisational and Individual Goals:** It view conflict between the goal of the organisation and those of individuals as destructive. The positive aspect of conflicts such as overcoming weaknesses and generation of innovative ideas are ignored.

## Behavioural Science Approach

Under behavioural science approach, the knowledge drawn from behavioural science, namely, psychology, sociology and anthropology, is applied to explain and predict human behaviour. It focuses on human behaviour in organizations and seeks to promote verifiable propositions for scientific understanding of human behaviour in organizations. It lays emphasis on the study of motivation, leadership, communication, group dynamics, participative management, etc.

The essential characteristics of behavioural science approach are as under:

- (i) Data must be objectively collected and analyzed.
- (ii) Findings must be presented so that the distinction between cause and effect, as opposed to chance occurrences, is clear.
- (iii) Facts must be systematically related to one another within a systematic framework. Data collection alone does not constitute a science.
- (iv) The findings of a study must always be open to further examination and question.

The distinguishing feature of the behavioural sciences approach is the methodology employed in developing the research in the management discipline. The crux of the methodology lies in the collection and analysis of the relevant data. It is in this sense that this approach differs from the human relations approach. Further, the behavioural scientists made the following propositions:

- (i) An organisation is a socio-technical system.
- (ii) Individuals differ with regard to attitudes, perceptions and value systems. As a result, they behave differently to different stimuli under different conditions.

- (iii) People working in the organisation have their needs and goals which may differ from the organisational goals. Attempts should be made to achieve fusion between organisational goals and human needs.
- (iv) A wide range of factors influence inter-personal and group behaviour of people in organizations.

Many sociologists, psychologists, and social psychologists have shown considerable interest in studying the problems of management. Sociologists have contributed much to an understanding of the anatomy of organizations through their work on groups, cultural patterns, group cohesiveness, and cooperation. Among the sociologists who might be noted are Blak, Selznick, Homans, Dubin, Dalton, and Katz and Kahn. Psychologists have likewise contributed to management understanding through their illumination of the aspects of rational behaviour and influence, the sources of motivation, and the nature of leadership. Among the many in the area of individual and social psychology who have contributed materially to management are Maslow, McGregor, Argyris, Leavitt, Blake and Mouton, Sayles, Tannenbaum and his associates, Bennis, Fielder, Stogdill and Herzberg.

The behaviour school has drawn heavily on the work of Maslow. His development of need hierarchy to explain human behaviour and the dynamics of motivation process is an important contribution. Douglas McGregor built on Maslow's work in explaining his 'Theory X' and 'Theory Y'. Frederick Herzberg developed a two-factor theory of motivation. He made a distinction between the factors which either cause or prevent job dissatisfaction (hygienic factors), and those factors which actually lead to motivation (motivational factors).

In the area of leadership, Robert Blak and Jane Mouton developed and popularized the 'Managerial Grid'. Rensis Likert has identified and extensively researched four Management Systems ranging from System 1: Exploitive-Authoritative to System 4: Group Participative. Each system characterizes and organisational climate by employing several key dimensions of effectiveness such as communication, motivation, leadership and others.

To sum up, the behavioural sciences approach gives emphasis on increasing productivity through motivation and leadership. The central core of this approach lies in the following aspects of human behaviour: motivation, leadership, communication, participative management and group dynamics. The behavioural sciences have provided managers with a systematic understanding of one of the most critical factors in the process of management-the human element. Insights evolving from that understanding have been used to design work situations that encourage increased productivity. It has enabled organizations to formulate programmes to more efficiently train workers and managers, and it has effects in numerous other areas of practical significance.

### **Appraisal of Behavioural Science Approach**

The study of human behaviour is of great significance in management. Since an individual is a product of social system, his behaviour is not determined by organisational forces alone, but many forces like perception, attitudes, habits, and socio-cultural environment also shape his behaviour. Therefore, in understanding human behaviour in the organisation, all these factors must be taken into account. The behavioural approach suggests how the knowledge of human behaviour can be used in making people more effective in the organisation.

Behaviourists have enriched management theory through their contributions in the areas of group dynamics, motivation communication and leadership. However, they

**Table 1: Human Relations Approach vs. Behavioural Sciences Approach**

Human Relations Approach	Behavioural Sciences Approach
1. Human relations approach laid emphasis on the individual, his needs and behaviour.	1. Behavioural science approach stressed upon groups and group behaviour.
2. It focussed on inter-personal relationships	2. It focussed on group relationships.
3. It was based on the Hawthorne Experiments and so its scope is limited.	3. It refined the Human Relations Approach and has a wide scope. It is a much more systematic study of human behaviour in organisations.
4. It laid emphasis on informal groups motivation, job satisfaction and morale.	4. The behaviourists studied group dynamics, informal organisation leadership motivation, and participative management.

have failed in developing an integrated theory of management. Although study of human behaviour in organisations is extremely important yet management cannot be confined only to this area. There are other variable such as technology and environment which have an important bearing on the effectiveness of an organisation.

The behavioural sciences, refined as they might be, have not achieved the precision of the physical sciences. Often the complexities of the human factor and the organisational setting make exact predictions impossible. It is not uncommon for programmes based on sound behavioural principles to have unexpected results. It should also be noted that the finding of behavioural science research are tentative and require further investigation. They should not be treated as applicable to all situations. Behavioural guidelines can be helpful and profitable, but are must be taken not to accept them as being complete valid and applicable to all situations.

## Quantitative Approach

This approach is also called 'Mathematical', 'Operations Research' or 'Management Science' approach. The basic feature of the quantitative management thought is the use of mixed teams of scientists from several disciplines. This school used scientific tools for providing a quantitative base for managerial decisions. The techniques commonly used for managerial decision-making include Linear Programming, Critical Path Method (CPM), Programme Evaluation Review Technique (PERT), Games Theory, Queuing Theory and Break-Even Analysis.

The quantitative approach uses mathematical formulate for finding solutions to the problems that were previously unsolved. The abiding belief of the quantitative approach is that if management is a logical process, it may be expressed in terms of mathematical symbols and relationships. The basic approach is the construction of a quantitative model because it is though this device that the problem is expressed in its basic relationships and in terms of selected objectives. The construction of the model expresses the effectiveness of the system under study as a function of a set of variables at least one of which is subject control. The general form of operations research model is  $E = f(x_1, y_1)$ , where E represents the effectiveness of the system (profit, cost and the like)  $x_1$  the variables of the system which are subjected to control and  $y_1$  those which are not subject to control.

The quantitative approach to management has its root in the scientific management movement. Since Taylor advocated a logical sequence of problem formulation, fact finding, modelling, a tentative solution, testing, etc., his scientific approach could be classified as an early form of quantitative approach to management. A natural extension of the scientific management is the operations research.



The approach was updated so as to include development of mathematical models to represent a system under study. It may be noted that the development of models required the skills of many disciplines such as engineering, mathematics, economics, statistics, physical science, behavioural sciences and cost accountancy. The mathematical formulation enabled the managers to discover significant relationships that they could control.

Operations research (management science) came into existence during the First World War and gained popularity during the Second World War. In England, the same time, Thomas A. Edison was studying in America the process of anti-submarine warfare. However, their work did not have much impact on military operations until the Second World War broke out. Both England and the United States procured operations researchers to deal with their military problems. Operations research activity was considered to be so valuable that it was continued after the end of the War.

Another important development along with the growth in the number of quantitative techniques was the introduction of high speed digital computers. Starting in about 1970, the quantitative approach to management turned away from emphasis on narrow operations research techniques to the broader perspective of decision techniques and models building. It also incorporated computerised information systems and operations management. The latest emphasis of the quantitative approach marked a move towards a more broad-based management.

The techniques mentioned above that are used for managerial decision-making such as Linear Programming, Critical Path Method (CPM), Programmes Evaluation Review Technique (PERT), Games Theory are explained below. The application of such techniques helps in solving several problems of management such as inventory control, production control, price determination, etc.

## Linear Programming

Linear programming is the process of taking various linear inequalities relating to some situation, and finding the "best" value obtainable under those conditions. A typical example would be taking the limitations of materials and labor, and then determining the "best" production levels for maximal profits under those conditions. The use of the word "programming" here means "choosing a course of action."

In "real life", linear programming is part of a very important area of mathematics called "optimization techniques". This field of study (or at least the applied results of it) is used every day in the organization and allocation of resources. These "real life" systems can have dozens or hundreds of variables, or more. In algebra, though, you'll only work with the simple (and graphable) two-variable linear case.

The general process for solving linear-programming exercises is to graph the inequalities (called the "constraints") to form a walled-off area on the x, y-plane (called the "feasibility region"). Then you figure out the coordinates of the corners of this feasibility region (that is, you find the intersection points of the various pairs of lines), and test these corner points in the formula (called the "optimization equation") for which you're trying to find the highest or lowest value.

- The term 'Linear' is used to describe the proportionate relationship of two or more variables in a model. The given change in one variable will always cause a resulting proportional change in another variable.
- The word, 'programming' is used to specify a sort of planning that involves the economic allocation of limited resources by adopting a particular course of action or strategy among various alternative strategies to achieve the desired objective.

- Hence, Linear Programming is a mathematical technique for optimum allocation of limited or scarce resources, such as labour, material, machine, money energy etc.

### Components of Linear Programming Models

1. Objective function: is a mathematical expression that can be used to determine the total profit (or cost, etc., depending on the objective) for a given solution.
2. Decision variables: represent choices available to the decision maker in terms of amounts of either inputs or outputs.
3. Constraints: are limitations that restrict the alternatives available to decision makers. The three types of constraints are less than or equal to ( $\leq$ ), greater than or equal to ( $\geq$ ), and simply equal to ( $=$ ).
4. Parameters: Numerical values or constants.
5. Feasible solution space The set of all feasible combinations of decision variables as define by the constraints.

### Structure of Linear Programming Model

The general structure of the Linear Programming model essentially consists of three components.

- The activities (variables) and their relationships
  - The objective function and
  - The constraints
1. The activities are represented by  $X_1, X_2, X_3, \dots, X_n$ . These are known as Decision variables.
  2. The objective function of an LPP (Linear Programming Problem) is a mathematical representation of the objective in terms a measurable quantity such as profit, cost, revenue, etc.  
  
Optimize (Maximize or Minimize)  $Z = C_1X_1 + C_2X_2 + \dots + C_n X_n$  Where  $Z$  is the measure of performance variable  $X_1, X_2, X_3, X_4, \dots, X_n$  are the decision variables And  $C_1, C_2, \dots, C_n$  are the parameters that give contribution to decision variables.
  3. The constraints are the set of linear inequalities and/or equalities which impose restriction of the limited resources.

**The Effect of Constraints:** Constraints exist because certain limitations restrict the range of a variable's possible values. A constraint is considered to be binding if changing it also changes the optimal solution. Less severe constraints that do not affect the optimal solution are non-binding.

Tightening a binding constraint can only worsen the objective function value, and loosening a binding constraint can only improve the objective function value. As such, once an optimal solution is found, managers can seek to improve that solution by finding ways to relax binding constraints.

**Shadow Price:** The shadow price for a constraint is the amount that the objective function value changes per unit change in the constraint. Since constraints often are determined by resources, a comparison of the shadow prices of each constraint provides valuable insight into the most effective place to apply additional resources in order to

achieve the best **improvement** in the objective function **value**. The reported shadow price is valid up to the **allowable increase** or **allowable decrease** in the constraint.

### Assumptions of Linear Programming

Linear programming requires linearity in the equations as shown in the above structure. In a linear equation, each decision variable is multiplied by a constant coefficient with no multiplying between decision variables and no nonlinear functions such as logarithms. Linearity requires the following assumptions:

1. **Proportionality:** A change in a variable results in a proportionate change in that variable's contribution to the value of the function. Variables in LP models are assumed to exhibit proportionality. Proportionality deals with the contribution per unit of each decision variable to the objective function. This contribution is assumed constant and independent of the variable level. Similarly, the use of each resource per unit of each decision variable is assumed constant and independent of variable level. There are no economies of scale.
2. **Additivity:** Additivity deals with the relationships among the decision variables. Simply put their contributions to an equation must be additive. The total value of the objective function equals the sum of the contributions of each variable to the objective function. Similarly, total resource use is the sum of the resource use of each variable. This requirement rules out the possibility that interaction or multiplicative terms appear in the objective function or the constraints. For example, in Joe's van problem, the value of the objective function is 2,000 times the fancy vans converted plus 1,700 times the fine vans converted. Converting fancy vans does not alter the per van net margin of fine vans and vice versa. Similarly, total labour use is the sum of the hours of labour required to convert fancy vans and the hours of labour used to convert fine vans. Making a lot of one van does not alter the labour requirement for making the other.
3. **Divisibility:** The decision variables can be divided into non-integer values, taking on fractional values. Integer programming techniques can be used if the divisibility assumption does not hold. The problem formulation assumes that all decision variables can take on any non-negative value including fractional ones; (i.e., the decision variables are continuous). This assumption is violated when non-integer values of certain decision variables make little sense. A decision variable may correspond to the purchase of a tractor or the construction of a building where it is clear that the variable must take on integer values. In this case, it is appropriate to use integer programming.
4. **Certainty:** The certainty assumption is that each parameter (objective function coefficients, right-hand side, and technological coefficients) are known with certainty.

In addition to these linearity assumptions, linear programming assumes certainty; that is, that the coefficients are known and constant.

### Problem Formulation

With computers able to solve linear programming problems with ease, the challenge is in problem formulation - translating the problem statement into a system of linear equations to be solved by computer. The information required to write the objective function is derived from the problem statement. The problem is formulated from the problem statement as follows:

1. Identify the objective of the problem; that is, which quantity is to be optimized. For example, one may seek to maximize profit.
2. Identify the decision variables and the constraints on them. For example, production quantities and production limits may serve as decision variables and constraints.
3. Write the objective function and constraints in terms of the decision variables, using information from the problem statement to determine the proper coefficient for each term. Discard any unnecessary information.
4. Add any implicit constraints, such as non-negative restrictions.
5. Arrange the system of equations in a consistent form suitable for solving by computer. For example, place all variables on the left side of their equations and list them in the order of their subscripts.

The following guidelines help to reduce the risk of errors in problem formulation:

1. Be sure to consider any initial conditions.
2. Make sure that each variable in the objective function appears at least once in the constraints.
3. Consider constraints that might not be specified explicitly. For example, if there are physical quantities that must be non-negative, then these constraints must be included in the formulation.

### Transportation Problem

There is a type of linear programming problem that may be solved using a simplified version of the simplex technique called transportation method. Because of its major application in solving problems involving several product sources and several destinations of products, this type of problem is frequently called the transportation problem. It gets its name from its application to problems involving transporting products from several sources to several destinations. Although the formation can be used to represent more general assignment and scheduling problems as well as transportation and distribution problems.

The two common objectives of such problems are either:

1. Minimize the cost of shipping  $m$  units to  $n$  destinations or
2. Maximize the profit of shipping  $m$  units to  $n$  destinations.

#### *Terminology used in Transportation Problem*

- **Feasible Solution:** Non negative values of  $X_{ij}$  where  $i=1, 2, \dots, m$  and  $j= 1, 2, \dots$ . Which satisfies the constraints of supply and demand is called feasible solution.
- **Basic Feasible Solution:** If the number of positive allocations are  $(m+n-1)$ .
- **Optimal Solution:** A feasible solution is said to be optimal solution if it minimizes the total transportation cost.
- **Balanced Transportation Problem:** A transportation problem in which the total supply from all sources is equal to the total demand in all the destinations.
- **Unbalanced Transportation Problem:** Problems which are not balanced are called unbalanced.

- **Matrix Terminology:** In the matrix, the squares are called cells and form columns vertically and rows horizontally.
- **Degenerate Basic Feasible Solution:** If the number of allocations in basic feasible solutions is less than  $(m+n-1)$ .

### ***Basic Assumption behind Transportation Problem***

Let us consider a T.P involving  $m$ -origins and  $n$ -destinations. Since the sum of origin capacities equals the sum of destination requirements, a feasible solution always exists. Any feasible solution satisfying  $m+n-1$  of the  $m+n$  constraints is a redundant one and hence can be deleted. This also means that a feasible solution to a T.P can have at the most only  $m+n-1$  strictly positive component, otherwise the solution will degenerate.

It is always possible to assign an initial feasible solution to a T. P. in such a manner that the rim requirements are satisfied. This can be achieved either by inspection or by following some simple rules. We begin by imagining that the transportation table is blank i.e. initially all  $X_{ij} = 0$ . The simplest procedures for initial allocation discussed in the following section.

### ***Methods of solving Transportation Problem***

Following are the methods used to solve the transportation problem:

#### ***North-West corner rule***

The North West corner rule is the method for computing a basic feasible solution of a transportation problem, where the basic variables are selected from the North-West corner (i.e., top left corner). In this method we distribute the available units in rows and column in such a way that the sum will remain the same. The standard instructions for a transportation model are paraphrased below. We have to follow the steps given below:

1. Select the upper left corner cell of the transportation table and allocate as many units as possible equal to the minimum between available supply and demand.
2. Adjust the supply and demand numbers in the respective rows and columns.
3. If the demand for the first cell is satisfied, then move horizontally to the next cell in the second column.
4. If the supply for the first row is exhausted, then move down to the first cell in the second row.
5. If for any cell, supply equals demand, then the next allocation can be made in cell either in the next row or column.
6. Continue the process until all supply and demand values are exhausted.

#### ***Least Cost Method***

- 1) Determine the least cost among all the rows of the transportation table.
2. Identify the row and allocate the maximum feasible quantity in the cell corresponding to the least cost in the row. Then eliminate that row (column) when an allocation is made.
3. Repeat steps 1 and 2 for the reduced transportation table until all the available quantities are distributed to the required places. If the minimum cost is not unique, the tie can be broken arbitrarily.

### ***Vogel's Approximation Method (VAM)***

This method is based on the 'difference' associated with each row and column in the matrix giving unit cost of transportation  $c_{ij}$ . This 'difference' is defined as the arithmetic difference between the smallest and next to the smallest element in that row or column. This difference in a row or column indicates the minimum unit penalty incurred in failing to make an allocation to the smallest cost cell in that row or column. This difference also provides a measure of proper priorities for making allocations to the respective rows and column. In other words, if you take a row, you have to allocate to the cell having the least cost and if you fail to do so, extra cost will be incurred for a wrong choice, which is called penalty.

The minimum penalty is given by this difference. So, the procedure repeatedly makes the maximum feasible allocation in the smallest cost cell of the remaining row or column, with the largest penalty. Once an allocation is fully made in a row or column, the particular row or column is eliminated. Hence an allocation already made cannot be changed. Then you have a reduced matrix. Repeat the same procedure of finding penalty of all rows and columns in the reduced matrix, choosing the highest penalty in a row or column and allotting as much as possible in the least cost cell in that row or column. Thus eliminate another fully allocated row or column, resulting in further reducing the size of the matrix. Repeat till all supply and demand are exhausted.

A summary of the steps involved in Vogel's Approximation Method is given below:

1. Represent the transportation problem in the standard tabular form.
2. Select the smallest element in each row and the next to the smallest element in that row. Find the difference. This is the penalty written on the right hand side of each row. Repeat the same for each column. The penalty is written below each column.
3. Select the row or column with largest penalty. If there is a tie, the same can be broken arbitrarily.
4. Allocate the maximum feasible amount to the smallest cost cell in that row or column.
5. Allocate zero elsewhere in the row or column where the supply or demand is exhausted.
6. Remove all fully allocated rows or columns from further consideration. Then proceed with the remaining reduced matrix till no rows or columns remain.

### **Assignment Problem**

A special type of problem called the assignment problem is also an allocation problem. Here we have  $n$  jobs to perform with  $n$  persons and the problem is how to distribute the jobs to the different persons involved. Depending on the intrinsic capacity or merit or potential of the individual, he will be able to accomplish the task in different times. Then the objective function in assigning the different jobs to different persons is to find the optimal assignment that will minimize the total time taken to finish all the jobs by the individuals. For example, we have four different building activities say, construction of a hotel, a theatre, a hospital and a multi-storeyed building and there are four contractors competing for these jobs. Each contractor has to be assigned only one job. The allocation should aim to minimize the total time taken to complete the construction of all four activities after assigning only one job to one individual. In fact there are  $(4!)$  permutations possible for allocating 4 jobs to 4 contractors. We



have 24 possible ways and it is tiresome to list all the possible ways and find the best one. If we have more jobs to be allocated, it is even difficult to list out the different permutations of allocations, then what to speak of choosing the best combinations.

The problem may be stated formally as follows. Given an  $n \times n$  array of real numbers representing the individual return associated with assigning one item to one person. We have to find the best assignment so that the total return is optimal. Consider the following example, given below in the table.

Jobs	Men			
	A	B	C	D
1	5	6	8	7
2	4	7	6	6
3	5	4	6	5
4	6	7	4	6

Source: [http://www.zeeopedia.com/read.php?assignment\\_problems\\_mathematical\\_formulation\\_of\\_the\\_problem\\_operations\\_research&b=66&c=36](http://www.zeeopedia.com/read.php?assignment_problems_mathematical_formulation_of_the_problem_operations_research&b=66&c=36)

In the above example, the elements of the matrix represent the times taken by A, B, C and D in accomplishing the jobs 1, 2, 3 and we have to find which job is to be assigned to whom so that the total time taken will be minimum. This is the objective function. Thus, this is also an allocation problem. A solution can be found to the above problem by the algorithm used to solve the transportation problem of degenerate transportation problem. In this way only 4 cells will be allocated. This leads to problem of degenerate transportation problem. There should be  $(4 + 4 + 1) = 7$  allocations in the initial basic feasible solution, but we have only 4 allocations. Hence it is the degeneracy.

The solution to an assignment problem is based on the following theorem:

**Theorem:** If in an assignment problem we add a constant to every element of a row or column in the effectiveness matrix then an assignment that minimizes the total effectiveness in one matrix also minimizes the total effectiveness in the other matrix.

The following steps are followed to find an optimal solution.

- a) Subtract the minimum element in each row from all the elements in its row to make sure that at least we get one zero in that row.
- b) Subtract the minimum element in each column from all the elements in its column in the above reduced matrix, to make sure that we get at least one zero in each column.
- c) Having obtained at least one zero in each row and atleast one zero in each column, examine rows successively until a row with exactly one unmarked zero is found and mark ( ) this zero, indicating that assignment in made there. Mark (X) all other zeros in the same column, to show that they cannot be used to make other assignments. Proceed in this way until all rows have been examined. If there is a tie among zeros defer the decision.
- d) Next consider columns, for single unmarked zero, mark them ( ) and mark (X) any other unmarked zero in their rows.
- e) Repeat (c) and (d) successively until one of the two occurs.
  - ❖ There are no zeros left unmarked.

- ❖ The remaining unmarked zeros lie atleast two in each row and column. i.e., they occupy corners of a square.

If the outcome is (1), we have a maximal assignment. In the outcome (2) we use arbitrary assignments. This process may yield multiple solutions.

### Methods to solve Assignment Problem

Following are the methods used to solve the assignment problems:

#### *Hungarian Algorithm*

Sometimes if you proceed in the steps explained above, you get a maximal assignment, which does not contain an assignment in every row or column. You are faced with a question of how to solve the problem. In such a case, the effectiveness matrix has to be modified, so that after a finite number of iterations an optimal assignment will be in sight. The following is the algorithm to solve a problem of this kind and this is known as Hungarian algorithm. The systematic procedure is explained in different steps and a problem is solved as an illustration.

1. Starting with a maximal assignment mark (✓) all rows for which assignments have not been made.
2. Mark (✓) columns not already marked which have zeros in the marked-rows.
3. Mark (✓) rows not already marked which have assignments in the marked columns.
4. Repeat steps 2 and 3 until the chain of markings ends.
5. Draw lines through all unmarked rows and through all marked columns. (Check: If the above steps have been carried out correctly, there should be as many lines as there were assignments in the maximal assignment and we have at least one line passing through every zero.) This is a method of drawing minimum number of lines that will pass through all zeros. Thus all the zeros are covered.
6. Now examine the elements that do not have a line through them. Choose the smallest element and subtract it from all the elements the intersection or junction of two lines. Leave the remaining elements of the matrix unchanged.
7. Now proceed to make an assignment. If a solution is obtained with an assignment for every row, then this will be the optimal solution. Otherwise proceed to draw minimum number of lines to cover all zeros as explained in steps 1 to 5 and repeat iterations if needed.

### Maximization in Assignment Model

The problem of maximization is carried out similar to the case of minimization making a slight modification. The required modification is to multiply all elements in the matrix by -1, based on the concept that minimizing the negative of a function is equivalent to maximize the original function.

### Impossible Assignment

Sometimes in an assignment model we are not able to assign some jobs to some persons. For example, if machines are to be allocated to locations and if a machine cannot be accommodated in a particular location, then it is an impossible assignment. To solve the problem in such situations we attach a very highly prohibited (say ∞) cost to the cell in the matrix so that there is absolutely no chance to get the assignment with infinite cost in the optimal solution.

## **PERT and CPM**

PERT is an acronym for "Programme Evaluation and Review Technique". This was created as a means to plan and accelerate the development of the Polaris Ballistic Missile. In USA the defence department developed a nuclear missile to be launched from beneath the ocean's surface by a mobile submarine, which would be an effective deterrent against aggression by an enemy. This paved way to plan how to design, develop and plan the different stages in the production of a missile and how quickly this task could be completed. A planning and scheduling technique named PERT gave the answer to these questions.

In any new venture, uncertainties are bound to creep in. PERT incorporated these uncertainties into a model, which provides a reasonable answer to these uncertainties. There are certain statistical aspects scheduling large projects consisting of numerous activities whose completion times are uncertain and are independent of one another. PERT is an event-oriented technique. By 'event' we mean reaching a certain stage of completion of the project.

Another technique, Critical Path Method, abbreviated as CPM, has emerged simultaneously. It is also a network technique but it is concerned with obtaining the trade-off, between cost and completion date for large projects. In any project consisting of several activities each activity can be completed in a normal duration with normal cost. If we employ more persons or skilled people or given overtime to the workers, the activity could be completed in a reduced duration known as crash duration. But this involves an increased cost in the form of additional resources. With CPM the amount needed to complete the various activities is assumed to be known with certainty. So, the direct costs for the activities increase and hence the cost of the project also increases. By reducing the activity duration of some or all possible completed ahead of the schedule. This will naturally reduce the overhead cost for the entire project. On one hand the direct expenses increase, if we shorten the activity duration, but, the indirect expenses for the project are reduced. We have to strike a balance or an optimum time schedule, or a least cost schedule is to be obtained. This is the purpose of the Critical Path Method. Thus CPM is not concerned with uncertain job times as in PERT. PERT is useful in research and developmental projects, whereas CPM is mostly used in construction projects, or in situations already handled, so that the details like the normal completion time, crash duration and cost of crashing are already known.

The following are the suggested applications when PERT or CPM is found useful:

- The construction of a building or of a highway,
- Planning and launching a new product,
- Scheduling maintenance for a project,
- The manufacture and assembly of a large machine tool,
- To conduct a music or drama festival, and
- Preparation of budget for a company.

## **Game Theory**

Game theory is a slightly oddly defined subject matter. A game is any decision problem where the outcome depends on the actions of more than one agent, as well as perhaps on other facts about the world. Game Theory is the study of what rational agents do

in such situations. You might think that the way to figure that out would be to come up with a theory of how rational agents solve decision problems, i.e., figure out Decision Theory, and then apply it to the special case where the decision problem involves uncertainty about the behaviour of other rational agents. Indeed, that is really what I think. But historically the theory of games has diverged a little from the theory of decisions. And in any case, games are an interesting enough class of decision problems that they are worthy of attention because of their practical significance, even if they don't obviously form a natural kind.

Game theory is the branch of decision theory concerned with interdependent decisions. The problems of interest involve multiple participants, each of whom has individual objectives related to a common system or shared resources. Because game theory arose from the analysis of competitive scenarios, the problems are called games and the participants are called players. But these techniques apply to more than just sport, and are not even limited to competitive situations. In short, game theory deals with any problem in which each player's strategy depends on what the other players do.

Situations involving interdependent decisions arise frequently, in all walks of life. A few examples in which game theory could come in handy include:

- Friends choosing where to go have dinner
- Parents trying to get children to behave
- Commuters deciding how to go to work
- Businesses competing in a market
- Diplomats negotiating a treaty
- Gamblers betting in a card game

All of these situations call for strategic thinking - making use of available information to devise the best plan to achieve one's objectives. Perhaps you are already familiar with assessing costs and benefits in order to make informed decisions between several options. Game theory simply extends this concept to interdependent decisions, in which the options being evaluated are functions of the players' choices.

The appropriate techniques for analysing interdependent decisions differ significantly from those for individual decisions. To begin with, despite the rubric game, the object is not to win. Even for strictly competitive games, the goal is simply to identify one's optimal strategy. This may sound like a euphemism, but it is actually an important distinction. Using this methodology, whether or not we end up ahead of another player will be of no consequence; our only concern will be whether we have used our optimal strategy. The reasons for this will become clear as we continue. In gaming, players' actions are referred to as moves. The role of analysis is to identify the sequence of moves that you should use. A sequence of moves is called a strategy, so an optimal strategy is a sequence of moves that results in your best outcome. (It doesn't have to be unique; more than one strategy could result in outcomes that had equal payoffs, and they would all be optimal, as long as no other strategy could result in a higher payoff.)

There are two fundamental types of games: sequential and simultaneous. In sequential games, the players must alternate moves; in simultaneous games, the players can act at the same time. These types are distinguished because they require different analytical approaches.

### Sequential Games

To analyse a sequential game, first construct a game tree mapping out all of the possibilities. Then follow the basic strategic rule: "look ahead and reason back".

1. Look ahead to the very last decision, and assume that if it comes to that point, the deciding player will choose his/her optimal outcome (the highest payoff, or otherwise most desirable result).
2. Back up to the second-to-last decision, and assume the next player would choose his/her best outcome, treating the following decision as fixed (because we have already decided what that player will pick if it should come to that).
3. Continue reasoning back in this way until all decisions have been fixed.

That's all there is to it. If you actually play out the game after conducting your analysis, you simply make the choices you identified at each of your decisions. The only time you even have to think is if another player makes a mistake. Then you must look ahead and reason back again, to see if your optimal strategy has changed. Notice that this procedure assumes that the other players are as smart as we are, and are doing the same analysis. While this may not be the case, it is the only safe assumption. If it is correct, we will have made our best possible decision. For it to be incorrect, an opponent must choose an option not in his/her own best interests.

### Simultaneous Games

Turning to simultaneous games, it is immediately apparent that they must be handled differently, because there is not necessarily any last move. Consider a simple, but very famous example, called the Prisoner's Dilemma: two suspected felons are caught by the police, and interrogated in separate rooms. They are each told the following:

- If you both confess, you will each go to jail for 10 years.
- If only one of you confesses, he gets only 1 year and the other gets 25 years.
- If neither of you confesses, you each get 3 years in jail.

We cannot look ahead and reason back, since neither decision is made first. We just have to consider all possible combinations. This is most easily represented with a game table listing the players' possible moves and outcomes. Table below, presents the outcomes for the first prisoner, for each possible combination of decisions that he and the other prisoner could make:

**Prisoner's Dilemma Game Table**

		First Prisoner's Decision	
		<i>Confess</i>	<i>Hold Out</i>
Other Prisoner's Decision	<i>Confess</i>	10 years	25 years
	<i>Hold Out</i>	1 year	3 years

Source: [http://msl1.miu.edu/ESD10/block4/4.4\\_-\\_Game\\_Theory.pdf](http://msl1.miu.edu/ESD10/block4/4.4_-_Game_Theory.pdf)



The game table (also called a payoff matrix) clearly indicates if that the other prisoner confesses, the first prisoner will either get 10 years if he confesses or 25 if he doesn't. So if the other prisoner confesses, the first would also prefer to confess. If the other prisoner holds out, the first prisoner will get 1 year if he confesses or 3 if he doesn't, so again he would prefer to confess. And the other prisoner's reasoning would be identical. There are several notable features in this game. First of all, both players have dominant strategies. A dominant strategy has payoffs such that, regardless of the choices of other players, no other strategy would result in a higher payoff. This greatly simplifies decisions: if you have a dominant strategy, use it, because there is no way to do better.

Thus, as we had already determined, both prisoners should confess. Second, both players also have dominated strategies, with payoffs no better than those of at least one other strategy, regardless of the choices of other players. This also simplifies decisions: dominated strategies should never be used, since there is at least one other strategy that will never be worse, and could be better (depending on the choices of other players). A final observation here is that if both prisoners use their optimal strategies (confess), they do not reach an optimal outcome. This is an important theme: maximizing individual welfare does not necessarily aggregate to optimal welfare for a group. Consequently, we see the value of communication. If the two prisoners could only communicate, they could cooperate and agree to hold out so they would both get lighter sentences. But without the possibility of communication, neither can risk it, so both end up worse off.

Although it was very simple, the above example laid the groundwork for developing strategies for simultaneous games:

- If you have a dominant strategy, use it.
- Otherwise, look for any dominated strategies and eliminate them.

Many games can be solved using these steps alone. Note that by eliminating a dominated strategy, you cross off a whole row or column of the game table, which changes the remaining strategies. Accordingly, if you can eliminate a dominated strategy, you should immediately check to see if you now have a dominant strategy. If you do not, then look for another dominated strategy (there may have been more than one originally, or you may have just created one or more). You can keep iterating in this way until you either find a dominant strategy, or the game cannot be reduced any further.

Therefore, game theory is exciting because although the principles are simple, the applications are far-reaching. Interdependent decisions are everywhere, potentially including almost any endeavour in which self-interested agents cooperate and/or compete. Probably the most interesting games involve communication, because so many layers of strategy are possible. Game theory can be used to design credible commitments, threats, or promises, or to assess propositions and statements offered by others. Advanced concepts, such as brinkmanship and inflicting costs, can even be found at the heart of foreign policy and nuclear weapons strategies – some the most important decisions people make.

## Basic Terminology of Game

Following are the basic terms used in game theory:

- **Backward Induction:** Backward induction is a technique to solve a game of perfect information. It first considers the moves that are the last in the game,



and determines the best move for the player in each case. Then, taking these as given future actions, it proceeds backwards in time, again determining the best move for the respective player, until the beginning of the game is reached.

- **Common Knowledge:** A fact is common knowledge if all players know it, and know that they all know it, and so on. The structure of the game is often assumed to be common knowledge among the players.
- **Dominating Strategy:** A strategy dominates another strategy of a player if it always gives a better payoff to that player, regardless of what the other players are doing. It weakly dominates the other strategy if it is always at least as good.
- **Extensive Game:** An extensive game (or extensive form game) describes with a tree how a game is played. It depicts the order in which players make moves, and the information each player has at each decision point.
- **Game:** A game is a formal description of a strategic situation.
- **Game Theory:** Game theory is the formal study of decision-making where several players must make choices that potentially affect the interests of the other players.
- **Mixed Strategy:** A mixed strategy is an active randomization, with given probabilities, that determines the player's decision. As a special case, a mixed strategy can be the deterministic choice of one of the given pure strategies.
- **Nash Equilibrium:** Nash equilibrium, also called strategic equilibrium, is a list of strategies, one for each player, which has the property that no player can unilaterally change his strategy and get a better payoff.
- **Payoff:** A payoff is a number, also called utility, that reflects the desirability of an outcome to a player, for whatever reason. When the outcome is random, payoffs are usually weighted with their probabilities. The expected payoff incorporates the player's attitude towards risk.
- **Perfect Information:** A game has perfect information when at any point in time only one player makes a move, and knows all the actions that have been made until then.
- **Player:** A player is an agent who makes decisions in a game.
- **Rationality:** A player is said to be rational if he seeks to play in a manner which maximizes his own payoff. It is often assumed that the rationality of all players is common knowledge.
- **Strategic Form:** A game in strategic form, also called normal form, is a compact representation of a game in which players simultaneously choose their strategies. The resulting payoffs are presented in a table with a cell for each strategy combination.
- **Strategy:** In a game in strategic form, a strategy is one of the given possible actions of a player. In an extensive game, a strategy is a complete plan of choices, one for each decision point of the player.
- **Zero-sum Game:** A game is said to be zero-sum if for any outcome, the sum of the payoffs to all players is zero. In a two-player zero-sum game, one player's gain is the other player's loss, so their interests are diametrically opposed.

## Systems Approach

In the 1960s, a new approach to management appeared which attempted to unify the earlier schools of thought. This approach is commonly referred to as 'Systems Approach'. Basically, it took up where the functional process management school left off to try to unify management theory. "A system viewpoint may provide the impetus to unify management theory. By definition, it could treat the various approaches, such as the process, quantitative and behavioural ones, as subsystems in an overall theory of management. Thus, the systems approach may succeed where the process approach has failed to lead management out of the theory jungle".

### Scientific Management vs. Quantitative Approach

Scientific Management Approach	Quantitative Approach
1. It advocates use of scientific methods in managing.	1. It advocates use of mathematical and statistical techniques for solving management problems.
2. It focussed on improving efficiency of workers and machines by finding one best way of doing things.	2. It focussed on finding right answers to managerial problems.
3. The main techniques of scientific management are time and motion studies.	3. The main technique of quantitative approach is operations research.
4. It lays stress on experiment and research for improving efficiency.	4. It lays stress on developing econometric models for taking managerial decisions.
5. The conceptual base of scientific management was provided by F.W. Taylor and his associates.	5. Quantitative approach was popularised by W.C. Churchman and his associates.

The systems approach is based on the generalization that an organisation is a system and its components are inter-related and inter-dependent. "A system is composed of related and dependent elements which, when in interactions, form a unitary whole. It is simply an assemblage or combination of things or parts, forming a complex whole. Its important feature is that it is composed of hierarchy of sub-systems. The world as a whole can be considered to be a systems in which various national economies are sub-system . In turn, each national economy is composed of its various industries, each industry is composed of firms, and of course, a firm can be considered a system composed of sub-systems such as production, marketing, finance, accounting and so on". Thus, each system may comprise several sub-systems and in turn, each sub-system be further composed of sub-systems.

An organisation as a system has the following characteristics:

- (i) A system is goal-oriented.
- (ii) A system consists of several sub-systems which are interdependent and inter-related.
- (iii) A system is engaged in processing or transformation of inputs into outputs.
- (iv) An organisation is an open and dynamic system. It has continuous interface with the external environment as it gets inputs from the environment and also supplies its output to the environment. It is sensitive to its environment such as government policies, competition in the market, technological advancement, tastes of people, etc.
- (v) A system has a boundary which separates it from other systems.

### Open System Concept

A system may be closed or open. A closed system is self-dependent and does not have any interaction with the external environment. Physical and mechanical systems

are closed systems. A closed system concentrates completely on internal relationships, i.e. interaction between sub-systems only. Because of lack of interaction with environment, it is unable to monitor changes occurring in the external environment. On the other hand, an open system has active interface with the environment through the input-output process as shown in Figure 1. It can respond to the changes in the environment through the feedback mechanism. That is why modern authors consider organisation as an open system.

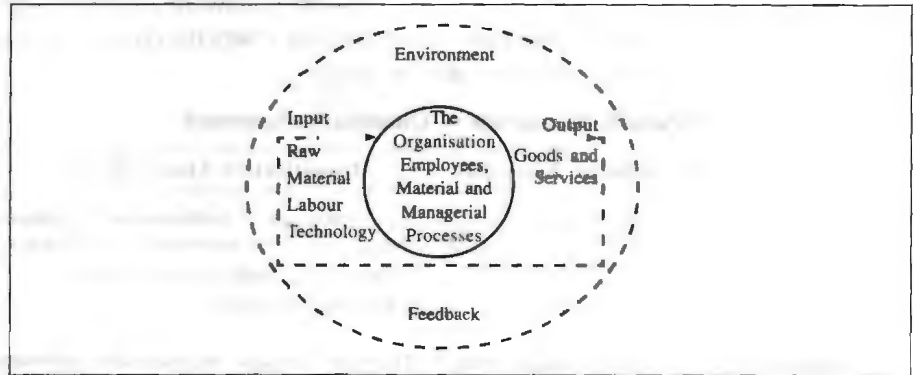

**Figure 1: Open System View of Organisation**

An open system obtains inputs, such as raw materials, layout, capital, technology and information, from the environment. Operations are performed upon the inputs and combined with the managerial process to produce desirable outputs which are supplied to the environment (i.e., customers). Through a feedback process, the environment's evaluation of the output becomes part of the inputs for further organisational activity. If the environment is satisfied with the output, business operations continue. If it is not, changes are initiated within the business systems so that requirements of the customers are fully met. This is how an open system responds to the forces of change in the environment.

## Features of Systems Approach

The systems approach is far more superior to classical and neo-classical approach because of the following features:

- (i) **Open system View of Organisation:** The classical theory treated organisation as a closed system. But moderns theory considers organisation as an open system which has continuous interaction with the environment. It gets various resources from the environment and transforms them into output desired by the environment. Due weightage has to be given to the environmental factors affecting the management of an organisation.
- (ii) **Adaptive System:** Organisation is an open system; its survival and growth in a dynamic environment demand an adaptive system which can continuously adjust to changing environment. Management tends to bring changes in the sub-systems of the organisations to cope up with the challenges of environmental forces. Since there is a provision of feedback mechanism, management can evaluate its performance and take corrective actions. The basic role of management is considered in terms of its adaptability to environment.
- (iii) **Interdependent Sub-systems:** An organisation is a system consisting of several sub-systems. For example, in a business enterprise, production, sales and other departments and sub-systems. All these sub-systems are functionally interacting and interdependent. They are used together into an organic whole through goals, authority flows, resources flows and so on.

- (iv) **Whole Organisation:** The system approach provides a unified focus to organisational efforts. It gives managers a way of looking at the organisation as a whole that is greater than the sum of its parts. The stress is laid on integration of various sub-systems of the organisation to ensure overall effectiveness of the system.
- (v) **Synergy:** The output of a system is always more than the combined output of its parts. This is called the law of synergy. The parts of system become more productive when they interact with each other than when they act in isolation.
- (vi) **Multi-disciplinary:** Modern theory of management is enriched by contributions from various disciplines like psychology, sociology, economics, anthropology, mathematics, operations research and so on.

### Appraisal of Systems Approach

The systems approach is based on the General System Theory and is of great significance to the management of modern organisation. It examines interrelationship and interdependency among organisational part and seeks to answer questions arising from these relationships. It concentrates on the working of various sub-systems so as to ensure the survival and growth of the system.

The system approach is an attempt to design an overall theory of management. Interdependency and inter-relationships between various sub-systems of the organisation is adequately emphasized. A pressure for change in one sub-system generally has a direct or indirect influence on the other sub-systems also. Thus, the systems approach acknowledges environmental influences which were ignored by the classical theory. It emphasizes adaptability (ability to respond to change) as well as efficiency. Hence, rigid rules and regulations cannot deal with uncertain and uncontrollable events.

The systems approach represents a balanced thinking on organisation and management. It stresses that managers should avoid analyzing problems in isolation and rather develop the ability for integrated thinking. It provides a unified focus to organisational efforts. It stresses the dynamic, multi-dimensional and adaptive nature of organisations. It provides a strong conceptual framework for meaningful analysis and understanding of organisations. It recognizes the interaction and interdependence among the different variables of the environment. It provides clues to the to the complex behaviour of an organisation. It warns against narrow fragmented and piecemeal approach to problems by stressing inter-relationships.

The systems approach is criticized as being too abstract and vague. It cannot easily be applied to practical problems. It does not offer specific tools and techniques for the practising manager. Moreover, this approach does not recognize differences in systems. It fails to specify the nature of interactions and interdependencies between an organisation and its external environment.

### Contingency Approach

A review of the earlier schools of management helps us to place the current approach to management in perspective. The performance results of the management process school's universalist assumptions were generally disappointing. The behavioural approach to management was incomplete. Certain quantitative techniques worked in some situations and not in others. The quantitative people could not solve behavioural problems and behavioural people could not overcome operations problems adaptable

to quantitative solutions. Many authors believe that systems based theory could solve this dilemma. But this approach is also as yet incomplete. The latest approach to management which integrates the various approaches to management is known as 'contingency' or 'situational' approach.

The contingency approach is not new. Pigors and Myers propagated this approach in the area of personnel management as early as in 1950. However, the work of Joan Woodward in the 1950s marked the beginning of the contingency approach to organisation and management. Other contributors include Tom Burns, G.W. Stalker, Paul Lawrence, Jay Lorsch, and James Thompson. They analyzed the relationship between the structure of the organisation and the environment. Thus, contingency approach incorporates external environment and attempts to bridge the theory-practice gap. It does so in the systems framework. In other words, contingency approach as regards organisation as an open and dynamic system which has continuous interaction with environment.

According to Kast and Rosenzweig, "The contingency view seeks to understand the inter-relationships within and among sub-systems as well as between the organisation and its environment and to define patterns of relationships or configurations of variables. Contingency views are ultimately directed toward suggesting organisational designs and managerial actions most appropriate for specific situations".

The contingency approach to management is based upon the premise that there is no one best way to handle any of the management problems. The application of management principles and practices should be contingent upon the existing circumstances. Functional, behavioural, quantitative and systems tools of management should be applied situationally. There are three major parts of the overall conceptual framework for contingency management: (i) environment; (ii) management concepts, principles and techniques; and (iii) contingent relationship between the first two.

A general framework for contingent management has been shown in Figure 2. However, it is an abstract depiction of the contingency model. The environment (If) is an independent variable whereas management (Then) is a dependent variable. The independent "If's" are along the horizontal axis. The goal of contingency management is to fill in as many cells of the matrix as possible. For example, in the bottom left-hand cell of the matrix, a relevant environmental condition would be identified (one or a combination of the "if's") and then be contingently related to an appropriate management (one or more of the "then's") for the most effective goal attainment possible.

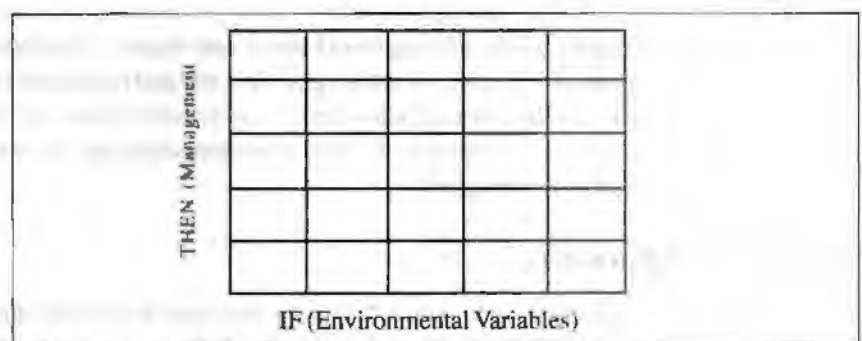

Figure 2: Conceptual Framework of Contingency Model.



The contingency theory stresses that there is no one best style of leadership which will suit every situation. The effectiveness of a particular leadership style will vary from situation to situation. For instance, participative leadership may be more effective in an organisation employing professional personnel in a high technology operation in an atmosphere of non-materialistic orientation and free expression. On the other hand, authoritarian leadership would be more effective in an organisation which employs unskilled personnel on routine tasks in social values oriented towards materialism and obedience to authority.

### Evaluation of Contingency Approach

Contingency approach guides the managers to be adaptive to environmental variables. In other words, the managers should develop situational sensitivity and practical selectivity. Adoption of this approach can be useful in the formulation of strategies, design of effective organisations, planning information systems, establishing communication and control systems, shaping motivational and leadership approaches, resolving conflicts, managing change, etc. This approach highlights the multivariate nature of organisations and explains how organisations operate under varying conditions. With its help, managers can design structures which are highly appropriate to the respective situations. If an organisation is operating in a stable environment, it can have a mechanistic structure characterized by high degree of differentiation, centralization of authority, rigid hierarchical relationships, rules and regulations, etc. But if the environment is dynamic, organic structure would be more appropriate. Organic structure is characterized by decentralized decision-making, collaborative relationships, open communication, scope for innovative decision-making, etc.

Contingency approach suggests the managers to consider environmental contingencies while choosing their style and techniques. It discounts preconceived notions and liberated the managers from dogmas and rigid behaviour. The management principles and techniques should be tailored to meet the particular situation. Readymade solutions for all the situations are not available. Contingency approach tells the managers to be pragmatic and open-minded.

#### Systems Approach vs. Contingency Approach

Systems Approach	Contingency Approach
1. It lays emphasis on the inter-dependencies and interactions among systems and sub-systems.	1. It identifies the nature of inter-dependencies and the impact of environment of organisational design and managerial style.
2. It treats all organisations alike. Size of the organisation, and its socio-cultural setting are not considered.	2. Each organisation is to be studied as a unique entity.
3. It studies organisation at the philosophical level.	3. It follows an action-oriented approach and so is pragmatic. It is based on empirical studies.
4. It does not comment on the validity of the classical principles of management.	4. It rejects the blind application of the classical principles of management.
5. It simply lays down that the organisation interacts with the environment.	5. The impact of environment on the organisation structure and managerial style is the major concern of contingency approach.

Contingency approach is an improvement over systems approach. It not only examines the relationships sub-systems of the organisation, but also the relationship between the organisation and its environment. The contingency approach seems to hold a

great deal of promise for the future development of management theory and practice. The other approaches to management can all be incorporated into the contingency framework. However, the contingency approach suffers from two limitations. Firstly, it does not recognize the influence of management concepts and techniques on environment. Secondly, literature in contingency management is yet not adequate.

## Operational Approach

Koontz, O'Donnell and Weihrich have advocated the operational approach to management. In doing so, they have attempted to draw together the pertinent knowledge management by relating it to the managerial job, i.e., what managers do. This approach recognizes that there is a central core of knowledge about managing which exists in management such as line and staff, patterns of departmentation, span of management, managerial appraisal and various managerial control techniques. Many other pertinent elements of knowledge are derived from other fields such as application of system theory, motivation and leadership, decision-making, group behaviour and cooperative systems, communication, and mathematical analysis and practices.

Operational approach to management regards management as a universally applicable body of knowledge that can be brought to bear at all levels of managing and in all types of enterprises. At the same time, the approach recognizes that the actual problems managers face and the environments in which they operate may vary between enterprises and levels. It also recognizes that application of science by perceptive practitioner must take this into account in designing practical problem solutions.

The operational approach to management is based largely on the following fundamental beliefs that:

- (i) Management is an operational process initially best dissected by analyzing the management functions.
- (ii) If the knowledge of management is to be presented effectively, clear concepts are necessary.
- (iii) Experience with managing in a variety of situations can furnish grounds for distillation of basic truths-theory and principles-which have a clarifying and predictive value in understanding and improving practice.
- (iv) Principles of management can become the focal points for useful research both to ascertain their validity and to improve their applicability.
- (v) Managing is an art (like medicine and engineering) the should rely on underlying science-concepts, theory and principles and techniques.
- (vi) While the total culture and the physical and biological universe variously affect the manger's environment, as they do in every other field of science and art, management science and theory need not encompass all knowledge in order to serve as a useful foundation of management practice.

George R. Terry has advocated the use of "modified management process" approach. This approach is quite similar to operational approach suggested by Koontz, ODonnell and Weihrich. Terry feels that such an approach should be followed which can be termed the electric process school of management, featuring the basic frame work of the process approach modified by certain theories from other appropriate schools of

management thought. Electric means “consisting of what is selected” and this term has been interpreted to indicate taking the best from what is available in the management thought and working it into a single theory moulded around the process framework as the central core.

## Leading Management Thinkers

### F.W. Taylor

F.W. Taylor was the first person who insisted on the introduction of scientific methods in management and it was he who, along with his associates, made the first systematic study of management. He launched a new movement in 1910 which is known as ‘Scientific Management’. That is why, Taylor is regarded as the father of scientific management.

Taylor was born in 1856 in Philadelphia, U.S.A. He started his career as an apprentice in a small machine making shop in 1870 and rose to the position of chief engineer of Midvale Steel Works in 1884 at the age of 28. Taylor conducted a series of experiments over a period of more than two decades. He experimented with machines tools, speed metals and the like. One of his experiments led to the discovery of high speed steel which made him very popular. Other experiments related to the way men handled materials, machines and tools which led him to the development of a coordinated system of shop management. In short, he experimented in different fields to eliminate wastages of all types, increase the efficiency of workers and provide for functional management.

Taylor was a man of strong will and convictions. He wanted to apply scientific reasoning to management. After leaving Midvale Steel Works, he joined Bethlehem Steel Company where he introduced scientific management. He was highly opposed by the management and the workers and his services were terminated unceremoniously in 1901. Taylor presented his first paper entitled ‘A Piece Rate System’ in 1895. His second paper “Shop Management” was published in 1903. It focussed attention on his philosophy of management. His famous book “Principles and Methods of Scientific Management” was published in 1911 and his other contribution was “Testimony Before the Special House Committee” which was given in 1921. It may be pointed out that the last two works were combined in one book entitled ‘Scientific Management’ in 1947 by Harper & Brothers, New York.

### Henri Fayol

Henri Fayol was born in 1841 in Finance. He joined as junior executive in a French mining company in 1860 and rose to the position of its Chief Executive in 1888. As an engineer he was fully conversant with the principles and techniques of management. His workshop experience contributed a lot to his thoughts on management. He felt that there could be a single administrative science whose principles are universally applicable, irrespective of the type of the organisation and managerial situation. Because of his emphasis on universality of management principles, he is known as ‘Universalist’.

**Comparison of Taylor and Fayol**

Taylor (Scientific Management)	Fayol (Administrative Management)
1. He paid more attention to shop and factory management.	1. He gave more emphasis on the functions of managers and the management process as a whole.
2. He worked from bottom to top level. His centre of study was the operator at the shop levels.	2. He worked from top level to downwards laying stress on unity of command, unity of direction, coordination, esprit de corps, etc.
3. His approach was a kind of efficiency movement. Thus, it had a narrow perspective.	3. He had a wider perspective. His scheme was to evolve principles which could be applied to administration in different spheres.
4. He gave stress on increasing productivity rather than on human resources.	4. He showed regard for the human element by advocating principles such as initiative, stability of service and spirit of cooperation.
5. He is known as the father of Scientific Management.	5. He is known as the father of Management Process.

Fayol published a number of papers and books in his mother tongue. His classic book, 'Administration Industrielle et generale' (1919) was originally translated as 'General and Industrial Administration' (1929). It was translated as General and Industrial Management in 1949, some thirty years after its original publication.

Fayol's long practical experience is amply reflected in his written work. He tried to develop a theory of management. He discussed the principles of general management and argued that managerial ability can be acquired as any other technical ability. He not only recommended formal teaching in management but also practised it by founding the Centre for Administrative Studies in Paris. Thus, he was a pioneer in the field of management education. In brief, Fayol's views on management command acceptability even today because they are much in tune with the requirements of the management in the present day world. He has been rightly called the father of general management.

The quote Theo Haiman, "As long as we refer to Taylor as the father of scientific management, we would do justice to Fayol and his work to call him the father of principles of management". We can conclude the contribution of Taylor and Fayol in the words of Urwick, "The work of Taylor and Fayol was, of course essentially complementary. They both realized that the problems of personnel and its management at all levels is the key to industrial success. Both applied scientific methods to this problem. That Taylor worked primarily at the operative level from the bottom of the industrial hierarchy upwards, while Fayol concentrated on the managing director and worked downwards, was merely a reflection of their very different careers. But Fayol's capacity to see and to acknowledge this publicly was an example of intellectual integrity and generosity of spirit".

**Frank and Lillian Gilbreth**

Although their contributions were numerous, the Gilberths added two especially important features to scientific management. Franck Gilbreth (1868-1924) was an engineer, and he concentrated his attention on time and motion study. Working initially with bricklayers, he analyzed the actual motions involved in a job and sought to minimize fatigue through developing the one best way to do a job. Gilbreth developed a number of new techniques to assist in time study. For example; he developed micromotion study, which used a motion picture cameral and a large clock marked off in hundredths of seconds to analyze individual motions.

Lillian Gilbreth was the wife of Franch Gilberth. She was a scholar in her own right and noted psychologist. Her renowned work "The Psychology of Management" in a way laid the foundation of human relations. She helped her husband in his work and in spreading his ideas. She called for the recognition of psychological factors and their importance to the productivity of the workers. She advocated that management should take interest in workers.

### **Henry L. Gantt (1861-1919)**

Gantt is probably best remembered for his development of task-and-bonus system and his perfection of the Gantt Chart. Taylor's differential piece rate system was an incentive plan whereby the worker was paid on the basis of his daily output. Gantt's task-and-bonus system was so structured that the worker received a day's wage even if he did not complete the task. But if he completed the task in less than the prescribed time, he received a bonus.

The Gantt Chart is still used and is the forerunner of some of the scheduling techniques. Gantt like the Gilbreths was concerned about the human factor in management. In this Yale lecture of 1915 he explicitly noted that financial incentives are only one of numerous motives which influence men. He also recognized management's responsibility to the community and was concerned about the businessman's desire for profits over community services.

### **Harrington Emerson (1853-1931)**

Harrington Emerson referred to as the 'high priest of efficiency', was an engineer by profession. He proposed twelve principles of efficiency that were, according to his, intensely practical, tested, and extremely successful. He was one of the first practising efficiency engineers, and he also advocated applying the lessons learnt by the military to the problems of business organisations.

### **Oliver Sheldon**

On the basis of his experience in his military service and association with Coca Works of Rowntree and Company, Sheldon developed the concepts which he published in 1923 in the form of a book The Philosophy of Management. In this book, he tried to distinguish between management and administration. Sheldon attempted to mix social ethics with the practicality of scientific management. He concerned himself with the totality of management and its logical position in the community. This was a novel direction for management.

### **James D. Mooney**

Mooney wrote a book Principles of Organisation and Co-authored Onward Industry with Allan C. Railey. Mooney conceived of the idea that the principle of organisation employed by all great leaders throughout history must surely be same, he, therefore, set out on a search for all available literature. He developed three principles of organisation:

1. The Principle of Coordination,
2. The Scalar Principle, and
3. The Functional Principle.



## Elton Mayo

Elton Mayo is said to be the father of Human Relations Movement. He conducted experiments in human relations and presented his findings in his book "Human Problems of an Industrial Civilization", Published in 1933. The Studies at the Hawthorne Plant of Western Electric Company under his guidance are a landmarks in development of management thought. These showed that an organisation is not merely a formal lifeless structure, but a dynamic, live and vital social system.

Mayo discussed in detail the factors that cause a change in human behaviour. He concluded that the cause of increase in the productivity of the workers is not a single factor like changing working hours or rest pauses but a combination of these and several other factors. Considerate supervision, giving autonomy to the workers, allowing the formation of small cohesive groups of workers, creating conditions which encourage and support the growth of these groups and the cooperation between workers and management lead to increase in productivity.

Mayo's contribution to management thought lies in the recognition of the fact that workers' performance is related to psychological, sociological and physical factors. Hawthorned Study was an important landmark in studying the behaviour of worker and his relationship to the job, his fellow workers and the organisation. It discarded the engineering approach (as in Scientific Management) to the problems of work. Rather it proved that informal work-groups and the opportunity to be heard and participate in decision-making have an important impact on the productivity of the workers.

## Chester I. Barnard

Like Henri Fayol, Barnad (1886-1961) was also a practitioner. He rose to the position of the president of the New Jersey Bell Telephone Company. In his famous book, The Functions of the Executive, Barnad described organisation as a social system that requires human cooperation. He also introduced the concepts informal organisation, status, and communication.

According to Barnard, formal organisation is a cooperative system in which there are persons able to communicate with each other, and are willing to contribute towards a common purpose. It is the primary duty of a manager to stimulate people to high levels of effort. Organisational success, thus, depends on the manager's ability to obtain cooperation from the organisational members.

Barnard concentrated mainly on the working and efficiency of social systems. That is why, he is also known as the father of Social System School of management thought. He started with the individual, moved to cooperative organized endeavour, and ended with the executive functions. Barnard identified the following functions of an executive: (a) the maintenance of organisational communication, (b) securing essential services from individuals in the organisation, and (c) formulating and defining the purpose. By performing these functions, the executives can achieved good human relations in the organisation.

Barnard developed a new concept of authority known as acceptance authority. He suggested that a person will accept the communication as authoritative only when four conditions are satisfied : (a) he can understand the communication, (b) he believes that it is consistent with organisational purpose, (c) he believes it to be compatible with his own personal interests, and (d) he is mentally and physically able to comply with it.

Barnard is also remembered for his views on social responsibility of management. The philosophy of social responsibility of management emphasises that management should provide fair wages and security, and also create an atmosphere conducive to the growth and development of the worker as a good employee and citizen. The management should also satisfy the other groups with whom the organisation has interaction such as investors, customers, suppliers and community.

In brief, Chester I. Barnard was a dynamic trailblazer in the field of management. He studied the inter-relationships within the organisation and suggested cooperation between management and workers to achieve the goals of the organisation. His definition of formal organisation is regarded to be a major contribution in the field of management. He studied informal groups and communication with the organisation. He also laid emphasis on the external environment of the organisation.

### **Herbert A. Simon**

Herbert A. Simon, an American political and social scientist, got the Nobel Prize in Economics in 1978. He has several publications to his credit such as *Administrative Behaviour*, 1947, *Public Administration*, 1950, *Organisation*, 1958, *The New Science of Management Decision*, 1960, *The Shape of Automation for Men and Management*, 1965.

Simon examined the accepted principles of administration and found these contradictory as well as ambiguous. Simon criticized the principles of management propagated by earlier writers like Lyndall Urwick and Gulick. He decried these principles as 'myths', 'slogans' and 'homely proverbs'. He pointed out inherent contradiction in them. This led him to evolve a new approach to administrative organisation. This approach is known as decision theory approach. He felt that organisations are decision-making centres. For the effectiveness of the organisation all the decisions should be rational.

### **Douglas McGregor**

Douglas McGregor is popular for his "Theory X" and "Theory Y", which he presented in his book "The Human Side of Enterprise". He was a behavioural scientist and his central concern was the application of behavioural science research to the practice of management. He argued that the traditional organisation and management practices were based on certain assumptions about human nature such as an average being does not like work inherently, avoids responsibility and has little ambition. The assumptions are contained in Theory X which is based on the notion of cause and effect. McGregor's observation of human behaviour led him to formulate a different set of assumptions about human nature which he called theory Y. He found that people are active and they take initiative and like work and responsibility. He suggested participative management and managing by objectives for the motivation of such employees.

### **Rensis Likert**

Rensis Likert, a former director of the Institute of Social Research at the University of Michigan, conducted extensive research in the field of Leadership with the help of his associates. He enunciated four basic styles which he presented in his 'New Patterns of Management' published in 1961 and 'The Human Organisation' published in 1967. These styles of leadership are:

1. Exploitative-Authoritative.
2. Benevolent-Authoritative.

3. Consultative-Democratic.
4. Participative-Democratic.

### **Peter F. Drucker**

Born in Vienna in 1909, Peter Drucker is a contemporary write on management practice. The ideas he put forward in “The Practice of Management” many years ago are still basic tenets of management throughout the globe. Drucker’s extensive writings are a landmark in the management field. He is a legendary figure in management thought through his writings and consultancy.

Drucker viewed management as the ‘dynamic, life-giving element in an organisation’ which converts resources into result . He wrote about management at it is rather than as it should be. He maintained that management can never be an exact science. He laid more emphasis on practical experience than on formal degree in management or administration. He introduced the concept of management by objectives and self-control in early fifties. He maintained that economic performance is the ultimate test of effectiveness of management. He argued that a company can make a social contribution only if it is profitable. Drucker has also been concerned with futurity. He stressed that a manager operates in a turbulent environment. In order to be successful, he must predict environment and adapt his organisation to the environmental changes.

Peter Drucker is a contemporary management thinker. His works ‘The Practice of Management (1954), ‘Managing for Result’ (1964), ‘The Effective Executive’ (1967), ‘The Age of Discontinuity’ (1969) and ‘Management: Tasks, Responsibilities and Practices’ (1974) are most significant. The Practice of Management is a very useful guide to managers. “Managing for Results’ enables an executive to see his business in a better perspective. It tells how the executive can find the right things to do. It emphasis that economic performance is the specific function and business exists on account of economic performance. The ‘Effective Executive’ presents a systematic study of practices essential for the success of executives. This is regarded to be an indispensable book for executives. Drucker has discussed five principles in detail, viz, time management, personal contribution to the organisation, making strength productive, establishment of priorities and effective decision-making.

‘The Age of Discontinuity’ (1968) focussed on changes in technology and their implications for the economy. It emphasises the effects of shifts from manual work to mental work. Drucker mentioned the sharp discontinuities between the patterns and trends of the part fifty years and those of the future. For solving the problems which can make the society liveable, and understanding of the discontinuities is essential.

Management: Task, Responsibilities and Practices’ (1974) is a very comprehensive book. It is a compendium of Peter Drucker on management. This book discusses systematically the tasks of management and the nature of organisation. Drucker is of the view that in the success of managers lies the working of institutions and, in turn, the working of the society. He felt that manager need both a based competence and a will to perform. His observations are based on experience. Drucker treats management ‘not so much a science as an organized body of knowledge’.

Thus, Drucker’s contributions are substantial to different areas of management. His writings and thoughts bear testimony to his deep insights into the practice of management. He is renowned all over the world for his practicability and sophistication of views. His extensive writings are a landmark in contemporary management.

## Student Activity 2

### Summarize

The contributions of :

- Modern management thought
- Human relation school.
- Scientific management.
- Hawthorne study.

## Summary

The study of Organization and management is a must to understand the underlying principles of management. Various schools of thoughts have put forward theories to better understand the scope of management in organization. Management theory is yet one of the pivotal approaches employed to analyze the concept of management and organization. Commonly used analysis of approaches to organization and management is the three-fold categorization pivotal of classical, human relations and systems. The classical writers placed emphasis on purpose and structure, on the technical requirements of the organisation, on principles of management, and on the assumption of rational and logical behaviour. The human relations writers emphasized the importance of the informal organisation and the psychological and social needs of people at work. The systems approach attempts to integrate the work of the classical and human relations writers. Attention is focused on the organisation as a whole and the interactions between technical and social variables. The organisation is seen as an open system in continual interaction with the external environment.

More recent forms of analysis include contingency theory and social action. Contingency theory highlights possible means of differentiating between alternative forms of structures and systems of management.

It might be that the study of organisations is moving towards a more scientific value approach. But whatever the balance between philosophy and science, a knowledge of management theory will help with the complexities of management in modern work organisations.

## Keywords

**Classical theory:** It concentrates on the structure of the organization for the achievement of organizational goals and certain principles of management.

**Scientific management:** It emphasizes efficiency of lower levels of organization.

**Administrative Management:** Concerned with the determination of policies.

**Bureaucracy:** A form of rational organization characterized by division of labour, specialization, structure, impersonal relations, competence of personnel etc.

**Neo-Classical Theory:** This approach emphasizes on the importance of social and psychological factors in determining workers' productivity and satisfaction.

**Human relationists:** The neo-classical writers who were instrumental in creating a new image of man and the work place.

**Behavioral Science Approach:** This approach utilizes methods and techniques of social science, which emphasizes on motivation, individual drives, group relations, leadership, group dynamics and so forth.

**Quantitative Approach:** It uses scientific tools for providing a quantitative basis for Managerial decisions. It believes that management problems can be expressed in terms of mathematical symbols and relationships.

**Systems Approach:** It is based on the generalization that an organization is an open system composed of inter-related and inter-dependent elements.

**Contingency Approach:** It is concerned with the analysis of interaction of specific organizations with their external environment and the adoption of structure to meet the requirements of the situation.

**Operational Approach:** It regards management as a universally applicable body of knowledge that can be brought to bear at all levels of managing and in all types of enterprises.

**System:** A system is composed of related and dependent elements which when in interactions form a unitary whole.

**Closed system:** A closed system is self-dependent and there is no interaction of the system with the external environment.

**Open system:** An open system interacts with the environment obtaining inputs such as raw material, layout, capital, technology etc and operations are performed upon the inputs to produce desired outputs with the application of feedback process.

**Adaptive system:** A system, which can continuously adjust to changing environment.

**Synergy:** Law of synergy implies that the output of a system is always more than the combined output of its parts.

## Review Questions

1. Describe various Schools of Management Thought prevalent from time to time.
2. Write a note on the evolution of management thought. What are the recent trends in management thought?
3. Explain the evolution of management thought from the early pioneers to modern times.
4. Write an explanatory note on Henri Fayol's contribution to modern management.
5. Write an explanatory approach to the Scientific Management approach to the study of management.
6. "Fayol is considered as the father of modern management theory". Discuss.
7. Distinguish between Taylor and Fayol as far as the development of management thought is concerned.
8. Write short notes on:
  1. Human Behaviour School
  2. Mathematical School
  3. Operational Approach.
9. Discuss the contribution of Behavioural and System scientists to the development of management thought.
10. Distinguish between the following:
  - (a) Contingency approach and systems approach.
  - (b) Scientific management and quantitative approach.



11. Write a short note on Human Relations Approach to Management.
12. Distinguish between Human Relations and Scientific Management approach to Management.
13. Discuss in brief the contributions of Behavioural Science Approach and System Approach to the study of management.
14. Discuss the Systems Approach to the study of Management.
15. (a) What is systems approach to management? Explain the salient features of this approach.  
 (b) What are the major contributions of the Hawthorne experiments to the present day organisations?
16. "Elton Mayo is known as the father of Human Relations School". Comment.

### Further Readings

George C.S. *The History of Management Thought*, Second Edition, PHI.

Brech, E. F. L. *Organization: The Framework of Management*, Second Edition, Longman.

**MANAGERIAL SKILLS****LEARNING OBJECTIVES**

1. Levels of Management
2. Managerial Skills
3. The Job of a Manager
4. Managerial Roles

**Introduction**

The term 'Manager' conveys different meanings to different people as there are no prescribed duties and qualifications of a manager. In a big enterprise, there are two distinct classes of employees, viz., (a) operative employees and (b) personnel employed to supervise other employees. The personnel of second category are termed as managers. In the words of Edwin B. Flippo, "A manager is one who exercises authority and leadership over other personnel; the president (chief executive or general manager) of a company is certainly a manager and so also is the departmental head or a foreman." Thus, chief executive, departmental heads, section officers, foremen and supervisors are all managers as they are responsible for instructing and guiding other personnel.

**Levels of Management**

The term 'levels of management' refers to a line of demarcation between various managerial positions in an organisation. The number of levels of management increase when the size of the business and workforce increases. There is a limit to the number of subordinates a person can supervise. Levels of management are increased so as to achieve effective supervision.

The number of levels of management cannot be increased to an unlimited extent because it may create many problems. It may complicate the communication process and make coordination and control difficult. Therefore, it is desirable to restrict the number of levels of management. But the feasible span of control should not be widened to restrict the number of managerial levels. According to Urwick, "In determining the number of levels which are necessary, prime regard should be given to the span of control and not vice versa. Forcing managers to exceed their feasible span of control merely in order to reduce the number of levels will increase administrative and social distance".

In most of the big organisations, there are generally four levels of management, namely, top management, upper middle management, middle management and lower level or first line management. These have been shown in Figure 1.

**Top Level Management**

Top management of a company consists of the Board of Directors and the Chief Executive or the Managing Director. It is the ultimate source of authority and it

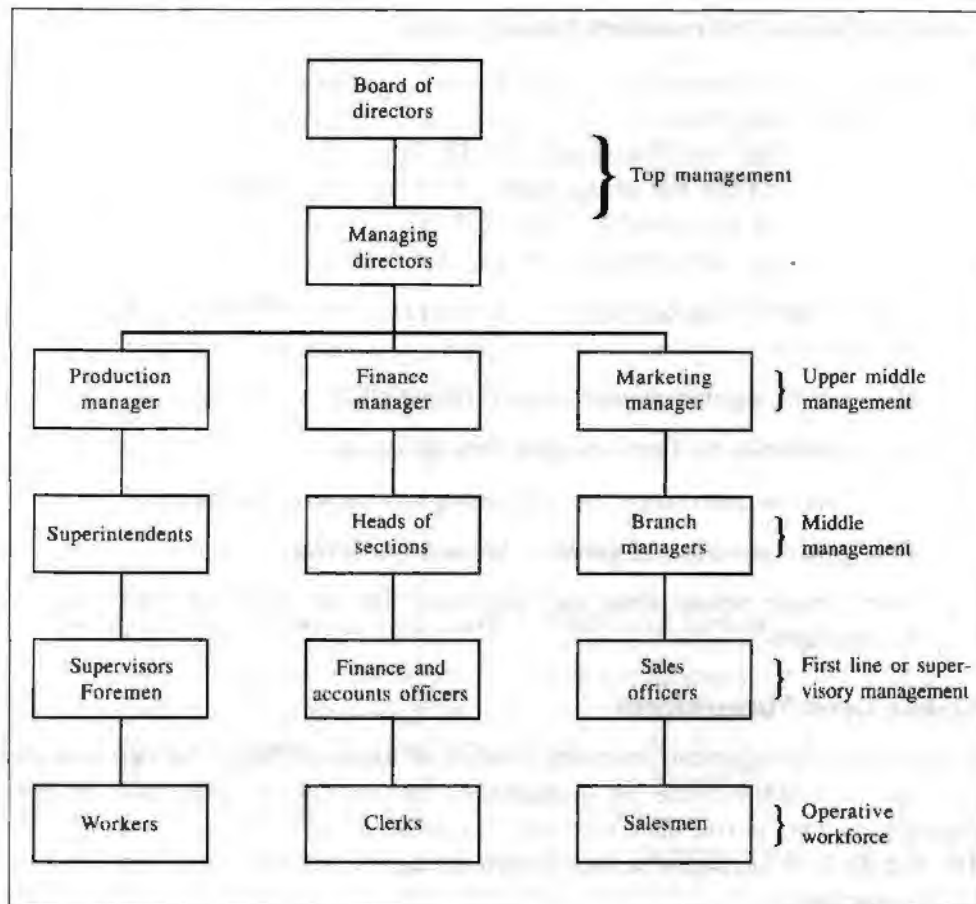

**Figure 1: Levels of Management**

establishes goals and policies for the enterprise. It is accountable to the owners of the business for the overall management. Top management also approves the decisions of the middle level management. It can issue orders and instructions and lay down guidelines which must be followed by the lower levels.

The responsibilities of the chief executive position include the interpreting of organisational policies and communicating the goals of the organisation. The chief executive thinks and takes decisions for the long run welfare of the enterprise. He puts into effect the policy decisions taken by the Board and maintains effective coordination in the organisation.

The functions performed by the top management are stated below:

- (i) Top management lays down the objectives of the enterprise.
- (ii) It prepares strategic plans and policies for the enterprise.
- (iii) It issues necessary instructions for the preparation of departmental budgets, schedules, procedures, etc.
- (iv) It appoints the executives for the middle-level.
- (v) It coordinates the activities of different departments.
- (vi) It controls the activities of all department with the help of reports, memoranda, etc.
- (vii) It builds and maintains relations with the outside public.

### **Upper Middle or Intermediate Management**

Upper middle management consists of heads of various divisions. As shown in Figure 1, Production Director, Finance Director and Marketing Director comprise the intermediate or upper middle management. The heads of functional divisions are in constant touch with the top management. They are responsible for the effective performance of their functional divisions. They pursue the policies and programmes laid down by the top management. They perform the following functions:

- (i) Upper middle management lays down plans and policies for the middle management.
- (ii) They put the top management's plans into practice.
- (iii) They coordinate the functioning of their divisions.
- (iv) They appraise and control the functioning of middle management.
- (v) They give directions and guidance to the lower levels.
- (vi) They prepare reports about the progress of their divisions for use by the top management.

### **Middle Level Management**

Middle level management generally consists of heads of functional departments. They are responsible to the top management for the efficient functioning of their departments. They devote more time to the organisation and functions of management. The middle level managers include branch managers, superintendents and heads of various sections.

Mary c. Niles, in her book 'Middle Management', has laid down the seven functions of middle management, which are as follows:

- (i) To run the details of the organisation, leaving the top managers as free as possible of their irresponsibilities.
- (ii) To cooperate in making a smoothly functioning organisation.
- (iii) To understand the interlocking of departments in major policies.
- (iv) To achieve the coordination between the different parts of the organisation.
- (v) To build up a contented and efficient staff where reward is given according to capacity and merit and not according to chance or length of service.
- (vi) To develop leaders for the future by broad training and experience.
- (vii) To build a team spirit where all are working to provide a product or service wanted by the society.

As shown in Figure 1, middle management may be upper middle management and lower middle management. In small organisations, there is only one layer of middle management. But where both of these exist, it is the upper middle management that gets authority direct from the top management.

### **Supervisory or Lower Level Management**

Supervisory management refers to those executives whose work is to control and direct operative employees. This level includes supervisors, foremen, finance and accounts officers, sales officers, etc. The essential feature of this level is that managers at this level are in direct contact with the operative employees. They are more

concerned with direction and control functions of management as compared to planning and organizing. They implement the policies of top management communicated to them by the middle level managers.

Managers at the lowest level are also known as first line supervisors. They represent a link between the management and the workers. The important functions of a supervisor or lower level executive are listed below:

- (i) To plan and organise the activities of the group.
- (ii) To arrange for necessary material, machines, tools, etc., for workers and to provide them the necessary working environment.
- (iii) To provide training to the workers.
- (iv) To supervise and guide the subordinates.
- (v) To solve problems of the workers.
- (vi) To communicate workers' problems to the higher level management.

### Intensity of Management Functions at Different Levels

From the above discussion, it can be concluded that all managers, top, middle and first line perform the same managerial functions. The main difference between their jobs in terms of management functions is emphasis. As shown in Figure 2, the top management spends more time on planning and organizing than does the middle and first line management. The middle management spends more time on directing and controlling than the top management. The first line managers devote less time on planning and organizing and more time on directing and controlling. Thus, the time and effort spent on different functions will depend on the level on which the manager is placed in the managerial hierarchy.

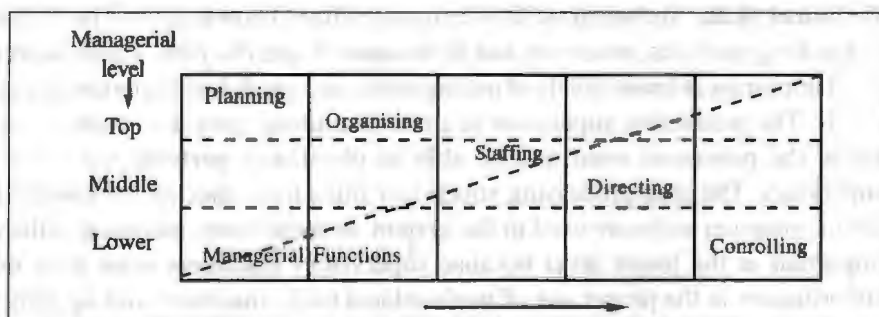

Figure 2: Management functions at different levels

### Managerial Skills

The job of a manager demands a mixture of many types of skills, whether he belongs to a business organisation, an educational institution, a hospital or a club. A manager is successful when he is able to make a smooth functioning team of people working under him. He is to reconcile, coordinate and appraise the various viewpoints and talents of people working under him towards the organisation goals. He has also to plan and organise the operations of the enterprise so that the subordinates are able to use the material resources in the best possible manner. For this, he must use the various skills in appropriate degrees.

We can broadly classify the skills required by managers into the following three categories: (i) Conceptual skills (ii) Human skills, and (iii) Technical skills as shown in Figure 3. Technical skills deal with jobs, human skills with persons and conceptual



skills with ideas. The three types of skills are interrelated and they are required by all managers. But the proportion or relative significance of these skills varies with the level of management.

Top management	Conceptual Skills	Human skills	Technical skills	Strategic planning and decision making
Middle management				Coordinating and planning for implementation
First-line management				Implementation

Figure 3: Managerial Skills

- (i) **Conceptual Skills:** Conceptual skill is the ability to see the organisation as a whole, to recognize interrelationships among different functions of the business and external forces and to guide effectively the organisational efforts. Conceptualisation requires extensive knowledge, imagination and ability to see the 'big picture' of the organisation. Conceptual skills are used for abstract thinking and for the concept development involved in planning and strategy formulation. Conceptual skills involve the ability to understand how the parts of an organisation depend on each other. A manager needs conceptual skills to recognize the interrelationships of various situational factors and, therefore, make decisions that will be in the best interests of the organisation.
- (ii) **Human Skills:** Human skills are essential to work with others and achieve their cooperation. Human skills are the abilities needed to resolve conflicts, motivate, lead and communicate effectively with others. Because all work is done when people work together, human relations skills are equally important at all levels of management. Every manager should be able to communicate effectively and also understand what thoughts others are trying to convey.
- (iii) **Technical Skills:** Technical skills refer to specialized knowledge and proficiency in handling methods, processes and techniques of specific jobs. These skills are most important at lower levels of management and much less important at upper levels. The production supervisor in a manufacturing plant, for example, must know the processes used and be able to physically perform the tasks he supervises. The data processing supervisor must have specialized knowledge about computer software used in the system. In most cases, technical skills are important at the lower level because supervisory managers must train their subordinates in the proper use of work-related tools, machines and equipment.

Besides the above skills, the managers, particularly at upper organisational levels, must also have design skills. These involve competencies to solve organisational problems in the light of the prevailing external environment of the organisation.

**Importance of Skills at Different Levels**

There are various levels of management and the managers at various levels perform all the functions of management though in varying degrees. Thus, the level of skills required at different managerial levels will be different as shown in Figure 3. Conceptual skills are critical in top executive positions whereas technical skills are very essential for lower level management. Technical skills can be learnt easily, but other skills cannot be learnt unless an individual has the potential and capacity and an inner urge to learn them.

Conceptual skills are highly important for top management which is responsible for formulating long range plans and policies for the whole business. Human skills are

important at all levels of management. This should be obvious as management is the process of getting things done through and with people. At every level, managers interact and work with other human beings. But technical skills are most important for the first line management which has to administer the use of equipments, tools, processes and procedures. The relative importance of technical skills decreases as one moves up to higher levels of management.

### Qualities of a Good Manager

In order to succeed in managing, a manager should possess the following qualities:

1. **Education:** A manager must be well-educated. In addition to general education, he must have specific education in business management/administration. Knowledge of business environment is also important to deal with the problems which the organisation may have to face in the future.
2. **Training:** Management skills are not inborn qualities. They are to be acquired through training. Therefore, it is necessary for a good manager to have some sort of training in the branch of management where he is working or going to work.
3. **Intelligence:** A manager should have somewhat higher level of intelligence than the average human beings. He should have the ability to think scientifically and analyze the problems accurately.
4. **Leadership:** Every manager is supposed to provide guidance and leadership to a number of subordinates. He should be able to channelize the energies of the subordinates for the achievement of organisational objectives. The manager can motivate the subordinates effectively if he has got leadership qualities.
5. **Foresight:** A good manager should have an open mind. He should be receptive to new ideas. He should be able to foresee the problems which might be faced by the business. Only through his foresightedness, he can take good decisions.
6. **Maturity:** A good manager should have broad interests. He should be emotionally mature and have balanced temperament. He should have high frustration tolerance also.
7. **Technical Knowledge:** A manager should have sufficient knowledge of the techniques of production being used in the enterprise. Adequate technical knowledge is necessary so that he may not be befooled by the subordinates.
8. **Human Relations Attitude:** An effort should be made to try and develop social understanding. He should treat his subordinates as human beings. A manager should try to maintain good relations with them. He should understand their problems and offer helping hand to them.
9. **Self-Confidence:** A manager should have self-confidence. He should take decisions after scientific analysis and implement them with full dedication. He should not shirk in taking initiative.

#### Student Activity 1

A manager's job is varied and complex. Managers need certain skills to perform the duties and activities associated with being a manager. Robert L. Katz found that managers need three essential skills or competencies: technical, human, and conceptual. Explain these three skills.

## The Job of a Manager

Management is **planning, organizing, staffing, directing** and controlling for the accomplishment of organisational goals. Any person who performs these functions is a manager. The first line manager or supervisor or foreman is also a manager because he performs these functions. The difference between the functions of top, middle and lowest level management is that of degree. For instance, top management concentrates more on long-range planning and organisation, middle level management concentrates more on co-ordination and control and lowest level management concentrates more on direction to get the things done from the workers. Every manager is concerned with ideas, things and people. Management is a creative process for integrating the use of resources to accomplish certain goals. In this process, ideas, things and people are vital inputs which are to be transformed into output consistent with the goals.

Management of ideas implies use of conceptual skills. It has three connotations. First, it refers to the need for a practical philosophy of management to regard management as distinct and scientific process. Secondly, management of ideas refers to the planning phase of management process. Lastly, management of ideas refers to creativity and innovation. Creativity refers to generation of new ideas and innovation refers to transforming idea into viable realities and utilities. A manager must be imaginative to plan ahead and to create new ideas.

Management of things (non-human resources) deals with the design of production system and acquisition, allocation and conversion of physical resources to achieve certain goals. Management of people is concerned with procurement, development, maintenance and integration of human resources in the organisation. Every manager has to direct his subordinates to put the organisation plans into practice.

The greater part of every manager's time is spent in communicating and dealing with people. His efforts are directed towards obtaining information and evaluating progress towards goals or targets and then taking corrective action. Thus, a manager's job primarily consists of management of people. Though, it is his duty to handle all the productive resources, but human factor is more important. A manager cannot convert the raw material into finished products himself; he has to take the help of others to do this. The greatest problem before any manager is how to manage the personnel to get the best possible results. The manager in the present age has to deal efficiently with the people who are to contribute for the achievement of organisational goals.

Peter Drucker has advocated that the managerial approach to handle workers and work should be pragmatic and dynamic. Every job should be designed as an integrated set of operations. The workers should be given a sufficient measure of freedom to organise and control their work environment. It is the duty of every manager to educate, train and develop people under him so that they may use their potentialities and abilities to perform the work allotted to them. He is also to help them in satisfying their needs and aspirations through incentives. For getting best contribution from the people working under him, he must provide them with proper environment. The manager must create a climate which brings in and maintains satisfaction and discipline among the people. This will increase organisational effectiveness.

## Managerial Roles

A role consists of the behaviour patterns expected of a manager within an organisation or a functional unit. Henry Mintzberg conducted a comprehensive survey on the subject of managerial roles and integrated his findings with the results of a study of

five practising chief executives. He identified ten basic roles performed by managers at all levels from foremen to chief executives and classified them under three heads: (1) interpersonal, (2) informational, and (3) decisional. These roles—organized sets of behaviours belonging to a position—describe what managers actually do, whereas functions of managers had historically described what managers should do.

The work of managers at all level is extremely complex and open-ended, at times more artistic than scientific. Although the specific activities of managers at different levels vary, they have important elements in common. Each plays a similar role (an organized set of behaviours) that is generally accepted as appropriate in a given situation. The crux of Mintzberg's work is the identification of ten managerial roles. Mintzberg acknowledged that a degree of arbitrariness is involved in the selection of these particular classifications, but he justified it pragmatically since manager role analysis and classification serves a useful purpose. Table 1 helps us to see managerial work across different levels and to integrate some of the vast amount of fragmented information on the subject. The ten managerial roles are described below.

### Interpersonal Roles

The following three interpersonal roles help managers keep their organisations running smoothly:

- (i) **Figurehead Role:** It describes the manager as a symbol, required by the status of his office, to carry out a variety of social, legal and ceremonial duties. A manager assumes this role because of the position occupied. It consists of such duties as signing certain documents required by law and officially receiving visitors.
- (ii) **Leader Role:** It describes the manager's relationship with his subordinates, his role to hire, train and motivate them. As a leader, the manager must bring the needs of the subordinates in accord with those of his organisation. The manager is also accountable for the activities of the subordinates.
- (iii) **Liaison Role:** It focuses on the managers; dealings with people outside his own organisation. The manager serves as a liaison between the organisation and outside contacts such as customers, suppliers, community and others.

### Informational Roles

Receiving and transmitting information are integral aspects of a manager's job. Managers need information for taking decisions and they pass on necessary informations to others to facilitate their tasks. The three informational roles are discussed below:

- i. **Monitor Role:** It refers to the manager's continually seeking and receiving relevant information in order to be well-informed. Much of the information is privileged; he alone receives it because of the contacts he develops in his liaison role and because of his status in the leader's role. He receives information usually through his network of contacts.
- ii. **Disseminator Role:** In this role, the manager passes on important information to subordinates. Some of this is factual information but some is based on the manager's analysis and interpretation of events. In either case, it is the manager's responsibility to ensure that subordinates have the information they need to carry out their duties.
- iii. **Spokesperson Role:** Managers act as spokesperson or representative of the organisation. They transmit information to people outside their units. They

represent the organisation in dealing with customers, suppliers, government departments, etc. In this role, the managers also speak for their subordinates to the superiors.

**Decisional Roles**

Information is the basic input to decision making for managers. Therefore, decision making roles of managers are as follows:

- i. **Entrepreneur Role:** In this role, the manager takes the initiative for bringing about change in his organisation. He looks for problems and opportunities and initiates steps to deal with them. He is thus an initiator and innovator.
- ii. **Disturbance Handler Role:** In this role, the manager takes charge when his organisation faces a major disturbance or crisis such as loss of a key executive, cancellation of an order, a strike, the destruction of a facility, etc.
- iii. **Resource Allocator Role:** In this role, the manager decides who will get what in the organisation. He schedules his own time according to his priorities; he designs his organisation, decides who will do what and allocates authority to take all important decisions.
- iv. **Negotiator Role:** In this role, the manager takes charge whenever his organisation must enter into crucial negotiations with other parties. His presence is required because he has the information and authority to make the 'real time' decisions that difficult negotiations require.

Mintzberg emphasized on the inseparability of these ten roles and advocated for viewing them as forming a 'Gestals' – an integrated whole. For example, status, as manifested in the interpersonal roles, brings information to the manager and it is this information (together with the status) that enables him to perform the decision making role effectively. Further, he observed that different managers emphasise different roles.

**Table 1: Mintzberg Roles of Managers**

Interpersonal Roles			
Figurehead	Leader	Liaison	
Performs symbolic duties: bestows honours, makes speeches, serves on.	Motivates, inspires, sets an example, legitimizes the powers of subordinates.	Maintains relationship with other organisations, government, industry groups, etc.	
Information Roles			
Monitor	Disseminator	Spokesperson	
Observes, collects and reviews data on the meeting of standards, notes compliance.	Transmits information and judgements about internal and external environments.	Speaks for the organisation. Lobbies and defends. Engages in public relations.	
Decisional Roles			
Entrepreneurs	Disturbance Handler	Resource Allocator	Negotiator
Initiates changes. Authorizes action. Sets goals. Formulates plans.	Handles conflicts and complaints. Counters actions of competitors.	Approves budgets, schedules and promotions. Sets priorities.	Works out agreements with customers, suppliers and agencies.



The managers in many organisations work with each other to establish the organisation's long range goals and to plan how to achieve them. They also work together to provide one another with the accurate information needed to perform tasks. Thus, managers act as channels of communication within the organisation.

**Managers are responsible and accountable:** Managers are responsible for seeing that specific tasks are performed successfully. They are usually evaluated on how well they arrange for these tasks to be accomplished. Managers are responsible for the actions of their subordinates. The success or failure of subordinates is a direct reflection of managers' success or failure. All members of an organisation, including those who are not managers, are responsible for their particular tasks. The difference is that managers are held responsible or accountable, not only for their own work, but also for the work of subordinates.

**Managers balance competing goals and set priorities:** At any given time, the manager faces a number of organisational goals, problems and needs, all of which compete for the manager's time and resources (both human and material). Because such resources are always limited, the manager must strike a balance between the various goals and needs. Many managers, for example, arrange each day's tasks in order of priority. In this way, managerial time is used effectively.

A manager must also decide who is to perform a particular task and must assign work to an appropriate person. Although, ideally each person should be given the task he would most like to do, this is not always possible. Sometimes individual ability is the decisive factor and a task is assigned to the person most able to accomplish it. But sometimes a less capable worker is assigned a task as a learning experience. And, at times, limited human or other resources dictate decisions for making work assignments. Managers are often caught between conflicting human and organisational needs and so they must identify priorities.

**Managers think analytically and conceptually:** To be an analytical thinker, a manager must be able to break a problem down into its components, analyze those components and then come up with a feasible solution. But even more important, a manager must be a conceptual thinker, able to view the entire task in the abstract and related it to other tasks. Thinking about a particular task in relation to its larger implications is no simple matter. But it is essential if the manager is to work towards the goals of the organisation as a whole as well as towards the goals of an individual unit.

**Managers make difficult decisions:** No organisation runs smoothly at all times. There is almost no limit to the number and types of problems that may occur - financial difficulties, problems with employees, or differences of opinion concerning an organisation policy, to name just a few. Managers are expected to come up with solutions to difficult problems and to follow through on their decisions even when doing so may be unpopular.

**Managers are mediators:** Organisations are made up of people and people disagree or quarrel quite often. Dispute with a unit of organisation can lower morale and productivity and they may become so unpleasant or disruptive that competent employees decide to leave the organisation. Such occurrences hinder work towards the goal of the unit or organisation; therefore, managers must at times take on the role of mediator and iron out disputes before they get out of hand. Settling conflicts requires skill and tact. Managers who are careless in their handling conflicts may later on find that they have only made matters worse.

The brief description of the managerial roles and responsibilities shows that managers must "change hats" frequently and must be alert to the particular role needed at a

given time. The ability to recognize the appropriate role to be played and to change roles readily is a mark of an effective manager.

### Student Activity 2

1. Discuss situations where you, as the human resource manager, might employ either a democratic or autocratic style of management
2. What is involved in being an effective manager?
3. What are some of the concerns to be considered by managers when working within different bureaucracies?
4. In today's world of work, characterized by a changing workforce, new information, communication technology and globalization, managers need to be skillful in their roles and flexible, adaptable and innovative.
  - a. What are the roles and skills that all managers must possess and the challenges they have to face?
  - b. Is it important for managers to be viewed as leaders?
  - c. Describe 'flexible working' and explain the reasons for the increase in 'flexible working' in today's business environment.
5. A newly appointed middle manager has come to you for advice. "I've taken over a team of 10 people," he says. "The previous manager was lenient and never complained when they failed to do what they'd promised, or missed deadlines. I'm trying to change this, but they think I'm being unreasonable and strict. How can I turn the situation around?"
  - a. Explain why the people in the team regard their new manager's behavior as "unreasonable and strict".
  - b. To resolve the problem, what should the manager do?

### Summary

The skills of a professional changes from level to level in the organisation. Managers at the top level require more of conceptual and design skills whereas at the lower level technical skills are needed more. Managers working at the middle level act as a bridge between the top level and lower level. They are supposed to translate the policies made by the top level into technical form which can be appreciated at the lower level in the organisation. Once they are implemented and the feedback comes middle managers have to again translate the technical details into a form which can be understood at the top level. Hence the need for almost equal level of technical and conceptual skills at the middle level. It is important to understand that human skills required are equally important at all the levels in the organisation and no one can escape from it. Every manager must learn the art of making everybody feel delighted.

### Keywords

**Manager:** A manager is one who exercises authority and leadership over other personnel.

**Levels of management:** It refers to a line of demarcation between various managerial positions in an organization.

**Top-level management:** It is the ultimate source of authority and it establishes goals and policies for the enterprise.

**Upper middle management:** This level of management is responsible for the effective performance of their functional divisions.

**Middle level management:** It consists of middle level managers who are responsible to the top management for the efficient functioning of departments.

**Supervisory Management:** It refers to those executives whose work is to control and direct operative employees.

**Managerial skills:** These are the skills required by managers, which include conceptual skills, human skills and technical skills.

**Conceptual skill:** It involves the ability to understand how the parts of an organization depend on each other.

**Human Skills:** Human skills are the abilities needed to resolve conflicts, motivate, lead and communicate effectively with others.

**Technical skills:** It refers to specialized knowledge and proficiency in handling methods, processes and techniques of specific jobs

**Role:** A role consists of the behavior patterns expected of a manager within an organization or a functional unit.

**Interpersonal roles:** It consists of figurehead role, leader role and liaison role, which help managers to keep their organizations running smoothly.

**Information roles:** Managers need information for taking decisions and they pass on necessary information to others to facilitate their tasks. It includes monitor role, disseminator role and spokesperson role.

## Review Questions

1. "Management is concerned with ideas, things and people". Comment.
2. "The job of a manager is to manage workers and work". Examine this statement.
3. What do you understand by the term 'Levels of Management'? Briefly describe the different levels of management.
4. Illustrate different levels of management with the help of a suitable chart.
5. What functions and duties are associated with top and middle management in a modern industrial unit? Explain briefly.
6. Write an explanatory note on the skills required by managers.
7. Explain the different types of skills required by managers and comment on their relative importance at different levels in the organisation.
8. What roles are performed by the managers? Explain each role in the context of a business enterprise.
9. Discuss Henry Mintzberg's classification of basic roles performed by managers in modern organisations.
10. Write explanatory notes on the following:
  - (a) The Manager and his job.
  - (b) Interpersonal roles of managers.
  - (c) Conceptual skills.

11. Answer the following:

- (a) Briefly explain the various levels of management.
- (b) What are the functions of top management?
- (c) State the skills required of a manager.
- (d) Why are human skills important?
- (e) What are the interpersonal roles of managers?
- (f) Briefly explain the decisional roles of managers as stated by Mintzberg.

**Further Readings**

Mintzberg, Henry, *The Nature of Managerial Work*, New York, Harper & Row.

Mintzberg, Henry, *A New Look at the Chief Executive's Job*, *Organisation Dynamics*, Winter.

# C H A P T E R

# 4

## MANAGERIAL PLANNING

### LEARNING OBJECTIVES

1. Principles of Planning
2. The Process of Planning
3. Essential Requirements of an Effective Plan
4. Derivative Plans
5. Planning Premises
6. Business Forecasting

### Introduction

Planning is the most basic of all management functions since it involves deciding of future course of action. The other functions of management, viz., organizing, staffing, directing and controlling, must reflect proper planning. A manager organizes, directs and controls to ensure the accomplishment of predetermined goals according to plans. Thus, planning logically precedes the execution of all other managerial functions. Although, all the functions intermeshed in practice, planning is unique in the sense that it establishes the objectives for the group effort and lays down steps to accomplish them before the manager proceeds to perform other functions.

### Definition of Planning

Planning is the process of deciding in advance what is to be done, who is to do it, how it is to be done and when it is to be done. It is the determination of a course of action to achieve the desired results. It bridges the gap from where we are to where we want to go. It makes it possible for things to occur which would not otherwise happen. Planning is a mental process requiring the use of intellectual faculties, imagination, foresight and sound judgement. In the words of Koontz, O'Donnell and Weihrich, "Planning is an intellectually demanding process; it requires the conscious determination of courses of action and the basing of decisions on purpose, knowledge and considered estimates".

Planning involves anticipation of future course of events and deciding the best course of action. It is basically a process of thinking before doing. "To plan is to produce a scheme for future action: to bring about specified results, at specified cost, in a specified period of time. It is a deliberate attempt to influence, exploit, bring about and control the nature, direction, extent, speed and effects of change. It may even attempt deliberately to create change, remembering always that change (like decision) in any one sector will in the same way affect other sectors". Planning is a deliberate and conscious research used to formulate the design and orderly sequence of actions through which it is expected to reach the objectives. Thus, we can say that planning is a systematic attempt to decide a particular course of action for the future. It leads



to determination of objectives of the group activity and the steps necessary to achieve them. From this, we can conclude that planning is the selecting and relating of facts and the making and using of assumptions regarding the future in the visualization and formulation of proposed activities believed necessary to achieve desired results.

### Nature of Planning

The nature of planning can be highlighted by studying the following characteristics:

- (i) **Planning is an Intellectual Activity:** Planning involves vision and foresightedness to decide the things to be done in future. It bridges the gap between where we are and where we want to go. It is not a simple process. It involves use of mental skills for the achievement of group objectives.
- (ii) **Planning Involves Selection among Alternatives:** Planning is a choice activity. The planning process involves finding of alternatives and selection of the best alternative to achieve specified objectives. Thus, decision making is an integral part of planning. Every manager finds himself surrounded by many alternatives. He has to pick up the best one.
- (iii) **Planning is Forward-Looking:** Planning means looking ahead. It is carried out to achieve some objectives in future. It may involve forecasting of future events such as customers, demand, competition, government policies, etc. In other words, the manager attempts to handle future events effectively through the process of planning. Thus, planning is futuristic in nature.
- (iv) **Planning is Related to Objectives:** Every plan specifies the objectives to be attained in the future and steps necessary to reach them. As Billy E. Gotez said, "Plans forecast which actions will tend towards the ultimate objective...Managerial planning seeks to achieve a consistent, coordinated structure of operation focused of desired ends".
- (v) **Planning is the Most Basic of all Management Functions:** Since managerial operations in organizing, staffing, leading, and controlling are designed to support the accomplishment of enterprise objectives, planning logically precedes the execution of all other managerial functions.
- (vi) **Planning is a Pervasive Function of Management:** Planning is a function of all managers, although, the character and breadth of planning will vary with their authority and with the nature of policies and plans outlined by their superiors.

### Is Planning Really Necessary

Planning is an activity of a highly ubiquitous character. Every function of business is planned in most of the enterprises as is evident from the fact that there are production plans, sales plans, financial plans, purchase plans, research and development plans and so on. This is done because of the necessity to ensure proper utilization of human and material resources to achieve the objectives of the business. Without proper planning, the affairs of any enterprise are most likely to be haphazard. Less important task may be done ahead of more important one or the same piece of work may be done by different individuals using different procedures or methods. There may be unnecessary repetition of certain business operation leading to wastage of efforts and resources. In short, without plans, action must become merely random activity, producing nothing but chaos. Therefore, planning is a must to achieve a consistent and coordinated structure of operations focussed on desired objectives.

Henri Fayol explained the importance of planning as a management function. According to him, "the maxim, Managing means looking ahead, gives some idea of the importance attached to planning in the business world, and it is true that if foresight is not the whole of management, at least it is an essential part of it... The plan of action is, at one and the same time, the result envisaged, the line of action to be followed, the stages to go through, and the methods to use". George Terry viewed planning as basic to the other managerial functions. Without the activities determined by planning, there would be nothing to organize, no one to actuate and no need to control. This stresses the importance of planning in the management process. Thus, planning is a prerequisite to good management.

Planning provides a rational approach to predetermined objectives as it requires a lot of systematic mental exercise on the part of planners. Planning helps in selecting from among alternative future courses of action for the enterprise as a whole and for its every department. It lays down clearly what every segment of the enterprise should do to achieve the organizational objectives. No organisation can achieve its objectives without proper planning because of certain obvious reasons. These reasons are as follows:

- i. Growing complexities of modern business because of rapid technological changes and keen competition in the market.
- ii. Rapid social, economic and political changes.
- iii. Recognition of social responsibilities.
- iv. Growth of trade unionism.
- v. Uncertainties caused by trade cycles.
- vi. Shortage of certain resources.
- vii. Increasing government control over business.
- viii. Need for research and development activities.
- ix. Fluctuations in macro and micro-economic variables.

These are the challenges before the managers of modern era which can be dealt with effectively only through proper planning. Looking at the significance of planning, management of every organisation should give due weightage to the planning function. Good planning is the foundation of efficient management.

### **Benefits of Planning**

Good planning can result in the following advantages:

- i. ***Focuses Attention on Objectives:*** Since all planning is directed towards achieving enterprise objectives, the very act of planning focuses attention on these objectives. Laying down the objectives is the first step in planning. If the objectives are clearly laid down, the execution of plans will also be directed towards these objectives.
- ii. ***Ensures Economical Operation:*** Planning involves a lot of mental exercise which is directed towards achieving efficient operation in the enterprise. It substitutes joint directed effort form uncoordinated piecemeal activity, even flow of work for uneven flow and deliberate decisions for snap judgements. This helps in better utilization of resources and thus minimizing costs.

- iii. **Reduces Uncertainty:** Planning helps the managers in performing their function of control. Planning and control are inseparable in the sense that unplanned action cannot be controlled because control involves keeping activities on the predetermined course by rectifying deviations from plans. Planning helps control by furnishing standards of control. It lays down objective and standards of performance which are essential for the performance of control function.
- iv. **Facilitates Control:** Planning helps the managers in performing their function of control. Planning and control are inseparable in the sense that unplanned action cannot be controlled because control involves keeping activities on the predetermined course by rectifying deviations from plans. Planning helps control by furnishing standards of control. It lays down objectives and standards of performance which are essential for the performance of control function.
- v. **Encourages Innovation and Creativity:** Planning is basically the deciding function of management. It helps innovative and creative thinking among the managers because many new ideas come to the mind of manager when he is planning. It creates a forward looking attitude among the managers.
- vi. **Improves Motivation:** A good planning system ensures participation of all managers which improves their motivation. It improves the motivation of workers also because they know clearly what is expected of them. Moreover, planning serves as a good training device for future managers.
- vii. **Improves Competitive Strength:** Effective planning gives a competitive edge to the enterprise over other enterprises that do not have planning or have ineffective planning. This is because planning may involve expansion of capacity, changes in work methods, changes in quality, anticipating tastes and fashion of people and technological changes, etc.
- viii. **Facilitates Coordination:** Planning secures unity of direction towards the organizational objectives. All the activities are directed towards the common goals. There is an integrated effort throughout the enterprise. It will also help in avoiding duplication of efforts. Thus, there will be better coordination in the organisation.

### Limitations of Planning

Sometimes, planning fails to achieve the desired results. There are many causes of failure of planning in practice. These are discussed below:

1. **Lack of Reliable Data:** There may be lack of reliable facts and figures over which plans may be based. Planning loses its purpose if reliable information is not available or if the planner fails to utilize the reliable information. In order to make planning successful, the planner must determine the reliability of facts and figures and must base his plans on reliable information only.
2. **Lack of Initiative:** Planning is a forward looking process. If a manager has a tendency to follow rather than lead, he will not be able to formulate good plans. Therefore, the planner must take the required initiative. He should be an active planner and should take adequate follow up measures to see that plans are understood and implemented properly.
3. **Costly Process:** Planning is time consuming and expensive process. This may delay action in certain cases. But it is also true that if sufficient time is not given to the planning process, the plans so produced may prove to be unrealistic.

Similarly, planning involves costs of gathering and analyzing information and evaluation of various alternatives. If the management is not willing to spend on planning, the results may not be good.

4. **Rigidity in Organizational Working:** Internal inflexibility in the organisation may compel the planners to make rigid plans. This may deter the managers from taking initiative and doing innovative thinking. So the planners must have sufficient discretion and flexibility in the enterprise. They should not always be required to follow the procedures rigidly.
5. **Non-acceptability of Change:** Resistance to change is another factor which puts limits on planning. It is a commonly experienced phenomenon in the business world. Sometimes, planners themselves do not like change and on other occasions they do not think it desirable to bring change as it makes the planning process ineffective.
6. **External Limitations:** The effectiveness of planning is sometimes limited because of external factors which are beyond the control of the planners. External stringencies are very difficult to predict. Sudden break-out of war, government control, natural havocs and many other factors are beyond the control of management. This makes the execution of plans very difficult.
7. **Psychological Barriers:** Psychological factors also limit the scope of planning. Some people consider present more important than future because present is certain. Such persons are psychologically opposed to planning. But it should not be forgotten that dynamic managers always look ahead. Long range well-being of the enterprise cannot be achieved unless proper planning is done for future.

### Measures to Overcome Limitations of Planning

Some people say that planning is a mere ritual in the fast changing environment. This is not a correct assessment of managerial planning. Planning may be associated with certain difficulties such as non-availability of data, lethargy on the part of planners, rigidity of procedures, resistance to change and changes in external environment. But these problems can be overcome by taking the following steps:

1. **Setting Clear-cut Objectives:** The existence of clear-cut objectives is necessary for efficient planning. The overall objectives should not only be understandable but rational also. The overall objectives of the enterprise must be the guiding pillars for determining the objectives of various departments. This would help in having coordinated planning in the enterprise.
2. **Management Information System:** An efficient system of management information should be installed so that all relevant facts and figures are made available to the managers before they perform the planning function. Availability of right type of information will help in overcoming the problems of complete understanding of the objectives and resistance to change on the part of the subordinates.
3. **Careful Premising:** The planning premises constitute a framework within which planning is done. They are the assumptions to be made regarding future happenings. In other words, it is a prerequisite to determine future settings such as marketing, pricing, Government policy, tax structure, business cycle, etc., before giving the final shape to the overall business plan. The planning premises should be set up very carefully. Due weightage should be given to the relevant



factors at the times of premising. It may be pointed out that the premises which may be of strategic significance to one enterprise may not be of equal significance to another because of size, nature of business, nature of market, etc.

4. **Business Forecasting:** Business is greatly influenced by economic, social, political and international environment. The management must have a mechanism of forecasting changes in such environment. Good forecasts will contribute to the effectiveness of planning.
5. **Dynamic Managers:** The persons concerned with the task of planning should be dynamic in outlook. They must take the required initiative to make business forecasts and develop planning premises. A manager should always keep in mind that planning is looking ahead and he is making plans for future which is highly uncertain.
6. **Flexibility:** Some element of flexibility must be introduced in the planning process because modern business operates in an environment which keeps on changing. For achieving effective results, there should always be a scope to make necessary addition, deletion, or alteration in the plans as is demanded by the circumstances.
7. **Availability of Resources:** Determination and evaluation of alternatives should be done in the light of resources available to the management. Alternatives are always present in any decision problem. But their relative plus and minus points are to be evaluated in the light of the resources available. The alternative which is chosen should not only be concerned with the objectives of the enterprise, but also capable of being accomplished with the help of the given resources.
8. **Cost-Benefit Analysis:** The planners must undertake cost-benefit analysis to ensure that the benefits of planning are more than the cost involved in it. This necessarily calls for establishing measurable goals, clear insight to the alternative courses of action available, premising reasonably and formulation of derivative plans keeping in view the fact that environment is fast-changing.

## Principles of Planning

The important principles of planning are discussed below:

1. **Principle of Contribution to Objectives:** The purpose of plans and their components is to develop and facilitate the realization of organizational aims. Long range plans should be interwoven with medium range plans which, in turn, should be meshed with short range ones in order to accomplish organizational objectives effectively and economically.
2. **Principle of Pervasiveness of Planning:** Planning is found at all levels of management. Strategic planning or long range planning is related to top management, while intermediate and short range planning are the concern of middle and operating management respectively.
3. **Principle of Limiting Factors:** Planning must take the limiting factors (manpower, money, machines, materials and management) into account by concentrating on them when developing alternative plans, strategies, policies, procedures and standards.
4. **Principle of Flexibility:** Flexibility should be built into organisation plans. Possibility of error in forecasting and decision making and future uncertainties are the two common factors which call for flexibility in managerial planning.



The principle of flexibility states that management should be able to change an existing plan because of change in environment without undue cost or delay so that activities keep moving towards established goals. Thus, an unexpected slump in demand for a product will require change in sales plan as well as production plan. Changes in these plans can be introduced only when these possess the characteristic of flexibility. Adapting plans to suit future uncertainties or changing environment is easier if flexibility is an important consideration while planning.

Both short-term and long-term plans need to have the element of flexibility. However, flexibility is more important in long range plans. The reason is not difficult to trace. Possibility of error or uncertainty is much higher for long-term plans than for short-term plans. However, the management can have flexibility in planning only within limits. External and internal rigidities and pressures greatly limit flexibility in managerial planning. Thus, the existing patterns of human behaviour, policy and procedure rigidities, union pressures, government policy and legal requirements are some important inflexibilities which restrict adaptability of plans to changing environment.

5. **Principle of Navigational Change:** This principle requires that managers should periodically check on events and redraw plans to maintain a course towards the desired goal. It is the duty of the navigator to check constantly whether his ship is following the right direction in the vast ocean to reach the destination as scheduled. The navigator changes the path of ship in case it is not going on the right path. In the same way, a manager should check his plans to ensure that these are progressing as required. He should change the direction of his plans if he faces unexpected events. It is useful if plans contain an element of flexibility. But built-in flexibility in plans does not mean that plans get revised automatically. It is the responsibility of the manager to adapt and change direction of plans to meet the challenges of constantly changing environment. In this regard, the role of a manager is analogous to the role of navigator of a ship which changes its course if it is not going on the right path.
6. **Principle of Commitment:** An organisation should plan in the future for a period of time sufficient to fulfil the commitments of the organisation. This principle helps in determining the length of the planning period. It suggests that the time period covered by planning should be related to the commitments of the organisation. If the commitments are defined in terms of long-term goals, the resources should be procured and deployed by the long-term plans to realize the goals.

## Types of Planning

We can classify planning on the basis of the following dimensions:

1. Organizational Level: Corporate, divisional and functional planning.
2. Focus: Strategic, operational and tactical planning.
3. Time Period: Long-range, medium-range and short-range planning.

## Levels of Planning

Based on organizational levels, planning exercise may take the form of (i) corporate planning, (ii) divisional planning and (iii) sectional or unit planning.

- (i) **Corporate Planning:** Corporate planning may be defined as a systematic and comprehensive process of planning taking account of the resources and capability of the organisation and the environment within which it has to operate and viewing the organisation as a total corporate unit. Corporate planning is strategic in nature and it covers the entire spectrum of organisational activities. It lays down the basic objectives, policies and strategies for the organisation as a whole. It usually covers a long period of five years or even more than this.

Corporate planning provides for future contingencies and attempts to match the organisational resources with the opportunities and threats in the external environment. Plans at the corporate level are formulated by the top level managers and they integrate various divisional and functional plans of the enterprise.

- (ii) **Divisional Planning:** Divisional planning relates to a particular division or department. Thus, it sets the objectives, policies and programmes of a particular division or department in tune with the corporate plans of the enterprise. The divisional plans, For instance, financial planning is the responsibility of finance manager and sales budget that of marketing manager.
- (iii) **Sectional or Unit Planning:** Sectional or unit planning is highly specific as it is done to achieve the divisional objectives. Its focus is to lay down detailed plans for a particular unit for the day-to-day guidance of personnel working there. The first-line managers are responsible for developing plans for their units in the light of the divisional plans. Such plans are more specific and detailed as compared to divisional and corporate plans.

### Student Activity 1

According to you what is the importance of planning and what type of planning do you think is very important. Explain in detail by giving their advantages and disadvantages.

### Focus of Planning

The focus of managerial planning may be on developing (i) strategic (ii) operational and (iii) tactical plans as discussed below:

- (i) **Strategic Planning:** Strategic planning is the process of deciding the objectives of the organisation and determining the manner in which the resources of the enterprise are to be deployed to realize the objectives in the uncertain environment.

A strategy represents the general direction of the organisational efforts. It is the way in which the management choose to utilize the organisation resources to reach its objectives. It involves multi-lateral relationships among the organisation, its resources and the environment. Strategic plans are made by the top management of the firm after taking into account the firm's strengths and weaknesses in the light of internal and external environment.

- (ii) **Operational Planning:** Operational planning is concerned with the efficient use of the resources already allocated and with the development of a control mechanism to ensure efficient operation so that organisational objectives are achieved. It lays down programmes, budgets, projects policies, procedures, rules, etc., to implement the strategic plan. In other words, an operational plan (also

Strategic Planning vs. Operational Planning		
Basic	Strategic	Operational Planning
1. Time Span	It covers a long period of time depending upon the nature of business and its environment.	It covers a short-term perspective upto one year.
2. Level of Management	It is done by the top level managers.	It is done by the middle level and lower level managers.
3. Scope	It covers the whole enterprise.	It may cover specific departments or functional areas of business.
4. Primacy	Strategic plans are based on organisational objectives and they precede operational plans.	Operational plans are based on strategic plans and they succeed strategic plans.
5. Details	Strategic plans contain relatively less details and are less specific.	Operational plans contain greater details and so are more specific.
6. Resources	Strategic plans are concerned with the acquisition and allocation of new resources.	Operational plans are made to utilise the given resources efficiently.
7. Environment	Strategic plans are made in the light of external environment. They are generally based on long-term forecasts of techno-logical changes, economic changes, socio-political changes, etc.	Operational plans are focused on the internal environment of the firm so as to make effective use of firm's resources.

called tactical planning) involves laying down how the firm's resources of the organisation will be used to help the firm achieve its objectives.

Operational plans provide the details of how the strategic plans will be accomplished. In other words, the details that activate the strategic plan are domain of operational planning. An operational plan is often more specific than a strategic plan.

- (iii) **Tactical Planning:** Tactical plans are made for short-term moves and maneuvers things necessary for supporting the strategic plans and achieving firm's objectives. They are required to meet the challenges of sudden changes in the environmental forces. For instance, tactical plans may be made to handle a sudden fall in the demand of firm's products of unexpected move by a competitor. Tactical planning may also become necessary to secure big orders by changing the price policy, terms of credit and discount, etc. The nature of a tactical plan is dictated by the threats posed by the environment.

### Range or Time Span of Planning

Business plans may be classified on the basis of time span covered into three categories, namely (i) long range (ii) medium range, and (iii) short range.

- (i) **Long Range Planning:** Long Range planning is the process of establishing long-term goals, working out strategies, policies and programmes to achieve these goals. In other words, long range planning sets long-term goals for the enterprise and formulates strategic plans for attaining these goals. It involves an attempt to anticipate, analyze and make decisions about basic problems which have significant effects well beyond the present operating horizon of the enterprise. Long range planning is done by the top management.

Long range planning generally covers a period ranging from 5 years to 20 years or even more. The period will vary from organisation to organisation. It may be five years for a departmental store and at least twenty-five years for a company intending to take up the production of timber. The purpose of long range planning may include technological leadership, increase in market share, globalization of production and marketing, public image, etc.

Long range planning may involve capital budgeting, product planning, project planning, acquisition of competing units. It may involve a complete change in outlook of the business. It deals with the broad technological, financial and competitive aspects of the business. Because of this, long range planning is associated with a great deal of uncertainty. Its success will be determined by the ability of the organisation to predict and deal with the environment.

- (ii) **Intermediate or Medium Range Planning:** Intermediate plans are made to support the medium term plans. They may relate to development of new products and markets, product publicity, increasing return on investment from the existing products and markets, etc. They are more detailed than the long range plans. Coordination between different departments is given greater emphasis.

Medium-term planning usually covers a period of more than one year but less than five years. The length of period may vary from one business to another depending upon the nature of business, risks and uncertainties, government control, changes in technology, nature of market, etc.

- (iii) **Short Range Planning:** Short range planning relates to period of upto one year, generally. Such plans are made to achieve short-term goals. Short range planning is concerned more with the current or near-future operations of the enterprise. It may be considered as a step by step approach to medium and long range planning. Short range plans are instrumental in implementing long-term plans. They are quite specific in nature such as change of product design, training of workforce, reduction of inventory levels, preparation of production budget and

BOX 2

Long-range, Medium-range and Short range Planning			
Basic	Long range Planning	Medium range Planning	Short range Planning
1. Time Span	Time horizon is generally more than five years.	Time horizon is more than one year, but less than five years.	Time span is restricted upto one year.
2. Focus	It is focused on the external environment of the business.	It is focussed on the long range plans and internal environment of business.	Its main focus is on internal environment of business. Linkage between various elements of business is greatly emphasised.
3. Uncertainty	It is very high.	It is moderate.	It is low.
4. Specificity	The actions are less specified.	The actions are specified, but details are lacking.	The actions are highly specified and detailed.
5. Linkage	It is linked with the corporate objectives.	It is linked with long range planning.	It is instrumental in implementing medium and long range planning.
6. Means	Strategies and long-term policies are formulated.	Policies, procedures, programmes and projects are quite often used.	Methods, rules, budgets, schedules, etc., are employed.

so on. Short-range planning is generally action-oriented and is the responsibility of lower level managers.

## The Process of Planning

It is difficult to specify the steps in the planning process for all organizations because of their differences in size and complexity. Nevertheless, it is possible to suggest some important steps for effective planning. The steps which are applicable to the most types of plans are discussed below:

- (i) **Establishing Objectives:** Planning is an intellectual process which an executive carries out before he does any job with the help of other people. But while planning, the question which must arise in the mind of the executive is "what is the objective of doing the job?" So the first step in planning is the determination of objectives. Objectives provide direction to various activities in the enterprise. Planning has no utility if it is not related to objectives.

The establishment of objectives can, at times, be more important than the objectives themselves since their establishment emphasizes how various people and units fit into the overall organisation framework. The formalization of this process can also be used to motivate individuals to achieve objectives which they have helped to establish. Objectives clarify the tasks to be accomplished. Overall objectives define what is to be accomplished in the general terms. The derivative objectives define what is to be accomplished in general terms. The derivative objectives focus on more details, that is, what is to be accomplished, where action is to take place, who is to perform it, how it is to be undertaken and when it is to be accomplished.

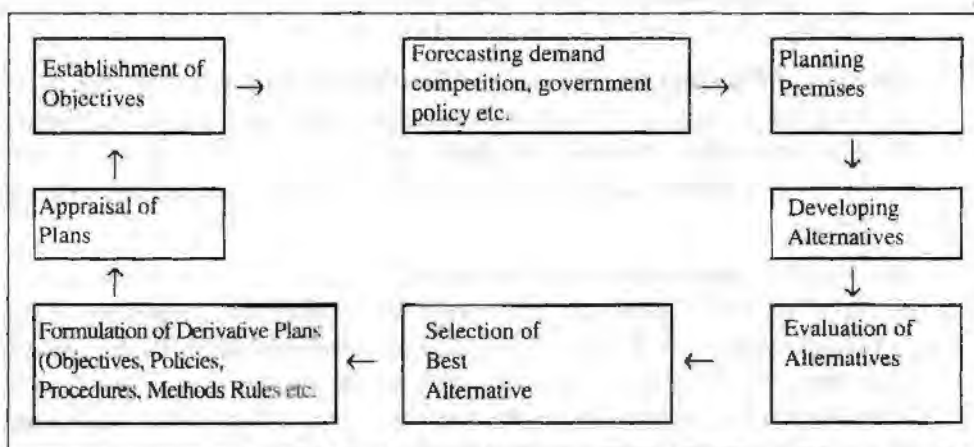

Figure 1: Steps in planning

- (ii) **Collection of Information and Forecasting:** Sufficient information must be collected in order to make the plans and sub-plans. Necessary information includes the critical assessment of the current status of the organisation together with a forward look at the environment that is anticipated. The assessment of external environment may consider the strong and weak points of the organisation. Collection of information and making forecasts serve as an important basis of planning.
- (iii) **Development of Planning Premises:** This step involves making assumptions concerning the behavior of internal and external factors mentioned in the second step. It is essential to identify the assumptions on which the plans will be based.



Assumptions denote the expected environment in the future and are known as 'planning premises'. Again, forecasting is important in premising. It helps in making realistic assumptions about sales, costs, prices, products, technological developments, etc., in the future. The assumptions alongwith the future forecasts provide a basis for the plans. Since future environment is so complex and uncertain, it would not be realistic to make assumptions in greater details about every environmental factor. It is advisable to limit premising to those factors which are critical or strategic to the planning process.

- (iv) **Search of Alternatives:** Usually, there are several alternatives for any plan. The planner must try to find out all the possible alternatives. Without resorting to such a search, he is likely to be guided by his limited imagination. At the time of finding or developing alternatives, the planner should try to screen out the most unviable alternatives so that there are only a limited number of alternative for detailed analysis. It may be noted that determination of alternative plans can be a time consuming task because objectives which have been established initially may be found to be inflexible. It is also possible that the assumption need revision in the light of the changed circumstances.
- (v) **Evaluation of Alternatives:** Once alternative action plans have been determined, they must be evaluated with reference to considerations like cost, long range objectives, limited resources, expected payback, risk and many intangible factors to select the satisfactory course of action. Many quantitative techniques are available to evaluate alternatives. The manager may take the help of these techniques to reach the most objective result. The best possible alternative may be chosen by the manager after detailed analysis. Sometimes, evaluation of available alternatives may disclose that two or more courses are advisable and so the concerned manager may decide to choose two or more alternatives and combine them to suit the requirements of the situation.
- (vi) **Selection of Plan and Development of Derivative Plans:** The final step in the planning process is to select the most feasible plan and develop derivative plans. The plans must also include the feedback mechanism. The hierarchy of plans must be both integrated and flexible to meet the changing internal and external environment.

The derivative plans are required to support the basic or overall plans because the latter cannot be executed effectively unless they are supported by the derivative or sub-plans. The derivative plans are developed within the framework of the basic overall plan. For instance, if an airline decides to acquire a fleet of new planes, it will be followed by the development of a host of derivative plans dealing with the employment and training of various types of personnel, the acquisition of spare parts, the installation of maintenance facilities, scheduling, advertising, financing and insurance.

### Essential Requirements of an Effective Plan

An effective plan is one which helps in the better management of the enterprise. In order to be effective, a plan should possess the following characteristics:

- (1) **The Plan should be Specific:** The more specific it is, the less chance there is for it to be misinterpreted. Objectives should be clearly defined. The means for carrying out the plan should also be indicated in unambiguous terms.
- (2) **The Plan should be Specific:** The more specific it is, the better it is. If facts are not available, reasonable assumptions must be made about the future.

- (3) **The Plan should be Complete and Integrated:** A plan is said to be complete when it is comprehensive enough to cover all actions expected from integrated one when various administrative plans are so welded into one another that the whole undertaking operates at the peak of its efficiency.
- (4) **The Plan should be Flexible:** No plan is infallible nor can it cover all possible contingencies. Conditions under which a plan will be most effective change as do the variables and factors on which the plan is formulated. Therefore, it is essential to introduce some flexibility in every plan.
- (5) **The Plan should be Capable of being Controlled:** Effective planning of business activities depends upon the ability to foresee with utmost accuracy the nature and requirements of future events relating to industry in general and the business undertaking in particular. Therefore, the plan must distinguish between controllable future environment for better administrative control.

## Derivative Plans

Planning consists of several components or derivative plans that are generally bound together. These components are also known as plans. They include projects, policies, programmes, strategies, procedures, methods and budgets. Now we shall discuss these plans which could be classified into (1) standing plans; and (2) single-use plans.

- (1) **Standing Plans:** The operational plans of a business organisation consist of a number of sub-plans or derivative plans which may be grouped into two broad headings, namely, standing plans, and single use plans. The standing plans are made to be used time and again. They are formulated to guide managerial decisions and actions on problems which are of recurring nature. That is why, standing plans are also known as 'repeated use' plans. Standing plans include policies, procedures, methods and rules and regulations.

Standing plans are formulated to achieve unity and uniformity of efforts in meeting repetitive situations arising at various levels of the enterprise. They are thus effective devices of coordination. They act as ready guides to deal with recurring problems. They help in the effective management of business enterprise in several respects as stated below:

- (i) Standing plans facilitate delegation of authority to lower levels without abdication of accountability at successively higher levels.
- (ii) They are effective means of achieving the goals of the enterprise. Goals may tend to be vague, complex, multidimensional and, sometimes, conflicting with one another in the absence of standing plans. In order to overcome such difficulties, it is essential to develop a hierarchy of policies, methods, procedures and rules to serve as ready frames of reference whenever there is some difficulty in taking a managerial decision.
- (iii) Standing plans help in achieving coordination in the enterprise. They tend to achieve consistency, uniformity and unity of efforts in the enterprises.
- (iv) Standing plans ensure quick action whenever need arises because there is no need to repeat the reasoning and analysis required initially to design a standing plan whenever a similar situation arises. Thus, they are great labour-saving devices as they provide frames of reference for tackling recurring situations.

- (v) Standing plans facilitate better administrative control. They provide the rational bases of evaluating the results of efforts of persons working at the various levels in the enterprise.
- (2) **Single-use Plans:** Single-use plans are made for handling non-recurring problems. They are also known as 'specific' plans as they are tailored to fit the

**BOX 3**

<b>Distinction between Standing and Single-Use Plans</b>	
<b>Standing Plans</b>	<b>Single-use Plans</b>
<ol style="list-style-type: none"> <li>1. It is made to meet a situation which is of recurring nature.</li> <li>2. It is used time and again.</li> <li>3. It is made to achieve uniformity and unity of efforts in meeting repetitive situations throughout the enterprise.</li> <li>4. The examples of repetitive use plans are:                             <ul style="list-style-type: none"> <li>(i) Policies</li> <li>(ii) Procedures</li> <li>(iii) Methods</li> <li>(iv) Rules.</li> </ul> </li> </ol>	<ol style="list-style-type: none"> <li>1. It is made to meet a particular situation only.</li> <li>2. It is used for a specific purpose only.</li> <li>3. It is made to cater to a particular situation. It ceases to exist after its purpose is served.</li> <li>4. The examples of single-use plans are:                             <ul style="list-style-type: none"> <li>(i) Programmes</li> <li>(ii) Projects</li> <li>(iii) Budgets.</li> </ul> </li> </ol>

specific situations. A single use plan is formulated to handle a non-repetitive, novel and unique problem. It can't be used again and again. It becomes obsolete after its purpose has been achieved. The examples of single-use plans are, programmes, projects and budgets.

**Planning Premises**

Planning involves taking of decisions by the management on the basis of assumptions of what is likely to happen in the future. These assumptions may be referred to as planning premises since they constitute the basis of planning. Such assumptions are nothing but forecasts about the likely shape of events in future. Every manager assumes that certain entities will behave in a particular way. The assumptions are not merely based on experience or intuition but also on systematic prediction with the help of quantitative techniques.

Planning premises constitute the framework within which planning is done. They provide the bedrock upon which the future course of action is based. In order to have effective planning, the plans must be based on sound premises. Therefore, the premises should be based on systematic forecasting. Though, derivation of premises in the form of forecasts is a rigorous form of research activity which involves huge cost, it is essential to enhance the effectiveness of planning. These forecasts are based upon both past events as well as expected events. It is wrong to say that only future estimates are taken as planning premises. Past events are a useful guide for deriving reliable planning premises.

**Types of Planning Premises**

- (i) **Internal and External:** The internal premises include those originating from the sales forecast, the existing policies and programmes of the organisation, capital investment policies, philosophy of management, etc. The abilities and skills of the workers are also significant internal premises. The external premises,

on the other hand, are derived from the external environment of the business. They relate to the political, economic, social and technological forces in which the organisation operates and the conditions which influence demand for the organisation's products. These factors are generally beyond the control of an organisation.

- (ii) **Controllable, Semi-controllable and Non-controllable:** Factors like materials, money and machines are controllable to a great extent. In these areas, management has maximum control over the future commitments. Semi-controllable premises are those assumptions about future which are under the partial control of a business like labour relations and marketing policy. Non-controllable premises are entirely beyond the scope of business as, for instance, government policy, international trade agreements, wars, natural calamities, innovations, etc.
- (iii) **Tangible and Intangible:** Tangible premises are those which are capable of being expressed in terms of quantitative units. Intangible premises are not measurable quantitatively. They include such factors as goodwill of the business, public relations, employee attitude and morale, etc.

### Significance of Planning Premises

Planning premises are assumptions providing a background on which the planning process is based. The very nature of planning requires that in all circumstances, some assumptions be made regarding future happenings. Therefore, before drawing up a master plan for a concern, it is necessary to determine future settings such as markets, prices, tax structure, government policies, trade cycles, etc. The selection of planning premises and their use in planning depend upon the skill and experience of the planners. But the difficulty normally faced by the planners is twofold: (i) selecting what premises to use; and (ii) evaluating the benefits obtained from the use of the premises.

Planning premises are not always the same for all industries, or even units in the same industry. Premises which may be of strategic importance to one industry may not be of strategic importance to another due to size of the business, nature of business and other variables. For example, passenger load factor is a strategically important issue to air and road transport industries while the same is not at all important to other industries. Likewise in closely regulated industry, the policies and practices of the government have great relevance for planning premises whereas the same is less significant in unregulated industries.

The effectiveness of planning will be determined by the quality of forecasts or premises on which it is based. If the premises are properly assessed, it will be possible to develop reliable plans for future.

### Planning Premises: Some Illustrations

In order to illustrate the types of planning premises the business enterprises should have, three industries, namely, cement, sugar and liquor have been chosen. The important planning premises in these lines of business are listed below.

#### Cement Industry

- (a) Internal premises – capital investment, scope for expansion in the future, sales forecasts.
- (b) External premises – product market, location, availability of raw materials.
- (c) Tangible premises – production capacity, scope for expansion.

- (d) Semi-controllable premises – labour policy, pricing policy, share of the firm in the market.
- (e) Uncontrollable premises – government policy regarding plant location and tax structure.

### **Sugar Industry**

- (a) Internal premises – capital investment and sales forecasts.
- (b) External premises – product market, location and availability of raw materials.
- (c) Tangible premises – production capacity, scope for expansion.
- (d) Semi-controllable premises – existing and future share of the company in the market.
- (e) Uncontrollable premises – Government licencing policy; taxation policy and socio-cultural factors, multinational corporations.

### **Business Forecasting**

Forecasting is a systematic attempt to probe future with the help of known facts. It is the "research procedure to discover those economic, social and financial influences governing business activity, so as to predict or estimate current and future financial, production and marketing operations" Thus, forecasting is the process of predicting future systematically. The result of this process is known as forecasts.

### **Significance of Forecasting**

Forecasting is an essential element of planning. It means estimating future on a systematic basis. Almost every business executive makes forecasts of one thing or the other. The need to foresee future on a systematic basis was very well emphasized by Henri Fayol. He was of the opinion that the entire planning in business is made up of a series of separate plans, called forecasts. L. Urwick also visualized the pervasiveness of forecasting in every aspect of business. According to him, "The man who engages staff usually has an eye to future organisational requirements". Thus, forecasting is a necessary activity for any business right from its birth.

Forecasting has assumed great importance in the modern business world which is characterized by growing competition, rapidity of changes in environment, fast technological changes and increased government control. It offers the following advantages:

- (i) It helps in effective planning by providing a scientific and reliable basis for anticipating future operations such as sales, production, inventory, supply of capital and so on.
- (ii) Forecasting aims at reducing the area of uncertainty that surrounds management decision-making with respect to cost, production, sales, profits, pricing, etc. If the future were known with certainty, there would have been no need of forecasting. But the future is highly uncertain and so there is a great need to have an organized system of forecasting in the organisation.
- (iii) Making and reviewing of forecasts on a continuous basis will compel the managers to think ahead and to search for the best possible decisions with a dynamic approach.



- (iv) Forecasting is necessary for efficient managerial control as it can disclose the areas where control is lacking. Forecast of sales a must in order to control the costs of production and the productivity of personnel. Forecasting will help in anticipating the areas where there is great need to be attentive to control the costs.

### **Limitations of Forecasting: The limitations of forecasting are as under:**

- (i) Though forecasting is a necessity in a modern business, it should not be forgotten that all forecasts are subject to a degree of error and they can never be made with a hundred percent accuracy. Guesswork can never be omitted from forecasting, though it can be reduced with the help of modern quantitative techniques.
- (ii) The quantitative techniques with the help of which forecasts are made have also got certain limitations. These techniques are based on certain assumptions. So the conclusions derived by the application of quantitative models can be no better than the assumptions on which they are based.
- (iii) Managers often neglect to examine whether the forecasts are supported by reliable information. Managers must use their knowledge, experience and available information with a great degree of skill and take care to make forecasts more dependable.

### **Steps in Forecasting**

The process of business forecasting involves the following steps:

- (i) **Understanding the Problem:** The first step in the forecasting process is the understanding of real problem about which forecasts are to be made. A manager must know clearly the purpose of forecasting. Forecasts may be made in regard to technological conditions, sales, choice of people, availability of finance and so forth. The clear understanding of the scope of forecasting will help the manager to probe the relevant information only.
- (ii) **Developing the Groundwork:** At this stage, the manager will try to understand what changes in the past have occurred. He can use the past data on performance to get a speedometer reading of the current rate (say of sales or production) and how fast this rate is increasing or decreasing. This will help in analyzing the causes of changes in the past.
- (iii) **Selecting and Analyzing Data:** There is a definite relationship between the choice of statistical facts and figures and the determination of why business fluctuations have occurred. Statistical data cannot be selected intelligently unless there is proper understanding of the business fluctuations. The reasons of business fluctuations will help in choosing the relevant information. After selecting the data, they are analyzed in the light of past changes. Statistical tools can be used to analyze the data.
- (iv) **Estimating Future Events:** Future events are estimated on the basis of analysis of past data. Here, the manager must use his past experience and judgement. He must know clearly what he expects in the future in the light of overall organisational objectives. He should make an estimate of future business from a number of probable trends revealed by the systematic analysis of data. The estimated results can be compared with actual results in the future. This will help in refining the process of forecasting.



## Techniques of Forecasting

The various techniques of forecasting may be classified into two major categories:

(i) Quantitative and (ii) Qualitative. Quantitative techniques apply various statistical tools to data for predicting future events. They include Time Series Analysis, Regression Analysis, Econometric Models and Extrapolation. Qualitative techniques employ mainly human judgement to predict future such as Historical perspective (business barometers), Panel Consensus, Delphi Method and Relevance Tree Method. These methods are used where data is not readily available. For instance, quantitative methods cannot be used to forecast technological environment. A brief discussion of various quantitative and qualitative methods of forecasting is given below.

1. **Time Series Analysis:** Time series analysis assists to identify and explain:

- (i) Any regular or systematic variation in the series of data which is due to some seasons; and
- (ii) Cyclical trends that repeat every two or three years or more.

With the help of time series analysis, a trend line can be fitted (by using the method of least squares) which is the best indicator of the trend. Time series analysis provides an initial approximation forecast that takes into account the empirical regularities which may be expected to persist. After the seasonal effects have been identified and measured, the original data may be adjusted for these influences, yielding a new historical time series consisting of the trend and seasonally adjusted data. The new time series may be used in the analysis and interpretation of cyclical and residual influences. This method has certain limitations also. Since the future does not always reflect the past, the time series analysis may give misleading results in some cases. Moreover, this method can be used only when data of several years are available.

2. **Regression Analysis:** Regression analysis is the means by which we can select from among the many possible relationships between different variables which are relevant to forecasting. If two variables are functionally related, then the knowledge of one will make possible an estimate of the other. For instance, if it is known that advertising expenditure and sales are correlated, then we can find out the probable increase or decrease in sales with the given increase or decrease in the advertising expenditure. Regression analysis also helps in forecasting where there is one dependent variable and several independent variables. The help of computer programmes may be sought to solve the regression equations that are very complex and time consuming.

3. **Econometric Models:** Econometrics refers to the application of mathematical economic theory and statistical procedures to economic data in order to verify economic theory and statistical procedures to economic data in order to verify economic theorems and to establish quantitative results. Econometric models take the form of a set of simultaneous equations. The number of equations may be very large in some cases. So the help of electronic data processing equipment may be sought to solve these equations. It is also significant to point out that the development of an econometric model requires sufficient data so that the correct relationships can be established. The econometric models reveal, in quantitative terms, the way in which various aspects of a problem are interrelated.

4. **Extrapolation:** This technique is used frequently for sales forecasting and other estimates when other forecasting methods may not be justified. It is the simplest method of forecasting. In many forecasting situations, it can be expected more

reasonably that the variable will follow its already established path. Extrapolation assumes the relative consistency in pattern of past movements in some time series. If this assumption is taken, the problem is to determine accurately appropriate trend curve and the values of its parameters. Numerous trend curves are suitable for business forecasting. They include arithmetic trend, semi-log trend, modified exponential trend, logistic curve, etc. Selection of an appropriate curve depends on empirical and theoretical considerations relevant to the forecasting problem.

5. **Historical Perspective (Business Barometers):** Historical perspective technique uses business barometers to make business forecasts. The term 'barometer' is used to indicate the economic situations. The assumption behind the use of business barometers, i.e., various indices, is that past patterns tend to repeat themselves in the future and that the future can be predicted with the help of certain happenings of the present. The various barometers which can be used in forecasting include gross national product, wholesale prices, consumer prices, industrial production, volume of money supply, stock exchange quotations, etc. Some of these index numbers may also be combined into a general index of business activity. The general index refers to general conditions of commerce and industry. However, this composite index may show quite contrary tendencies from those of some of its components. So proper care must be taken while using the index numbers for business forecasting. If the business barometer being used is reliable, it will reduce the chances of wrong forecasting.
6. **Panel Consensus Method:** Under this method, data is presented openly to a group of experts. The list of experts related to particular problem area is prepared with great care and the experts are brought together to have a face-to-face discussion and arrive at a consensus forecast. Such a forecast is expected to prove better as compared to a forecast made by one expert. Several experts can determine a better forecast than one working along.
7. **Delphi Method:** This method enjoys respectability due to its scientific minds of the people who possess the necessary expertise in the pertinent or related areas. Under this method, a panel of experts related to a particular problem area is prepared. Instead of bringing these experts together to have a face-to-face discussion, they are kept apart and their identity is kept secret from one another. This is done to prevent experts from being influenced by others and to eliminate the possibility of the emergence of a band-wagon mentality. The opinions of the experts are solicited by eliciting their response to a carefully prepared questionnaire. The answers collected are studied carefully to separate the answers to questions on which a general consensus has emerged. The experts who have differed with majority opinion are fed back the results of the first round of survey and are requested to communicate the reasons for their divergence. Similarly, in the case of such questions on which wide difference of opinion has surfaced, the same process is employed to narrow down the differences. The process of successive feedbacks and seeking of opinions continues until the experts re-evaluate their estimates and a better convergence of opinion emerges or at least the scatter of opinions gets narrowed. The final results are taken as the forecasts. It should be noted that the Delphi method would not give only one answer in all the cases.
8. **Relevance Tree Method:** In its normative application, the purpose of the relevance tree method is to help the business in determining objectives and predicting ways to attain them. According to this method, the feasibility of the future objective is judged first of all, and then by working backwards, attempt

is made to find the technological innovations needed to achieve the objective. In its exploratory application, the relevance tree method is similar to the decision tree method of decision making. It is used to develop alternatives and to determine the most desirable course of action.

### Student Activity 2

Prepare an assignment on: Business forecasting and take any one of the Industry Manufacturing or Retailing and purpose your Planning process and various techniques of Forecasting.

### Summary

The function of management starts with planning. It logically precedes the execution of all other managerial functions. It is the determination of a course of action to achieve the desired results. It bridges the gap between where we are to where we want to be. It is a mental process which requires the use of intellectual faculties, imagination, foresight and sound judgment. There are various types of plans on the basis of organisational level, focus, and time period. But the basic steps of planning remains the same and are applicable on all the types of plans. Adequate balance between rigidity and flexibility is crucial for the success of plans. Plans must be made in a manner so that control can be exercised otherwise they may go haywire. It must be complete and should be capable of integrating all the areas.

### Keywords

**Forecasting:** is a systematic attempt to probe future with the help of known facts.

**Time Series analysis:** Identify and explain any regular or systematic variations in the series of data which is due to some reasons and cyclical trends that repeat every two or three years or more.

**Regression analysis:** Regression analysis is the means by which we can select from among the many possible relationships between different variables which are relevant to forecasting.

**Econometric models:** The economic model reveal, in quantitative terms, the way in which various aspects of a problem are interrelated.

**Extrapolation:** This technique is used frequently for sales forecasting and other estimates when other forecasting methods may not be justified. Historical perspectives (Business Barometers): Historical perspectives techniques was business barometers to make business forecasts.

**Panel consensus method:** Data is presented openly to a group of experts.

**Delphi method:** A panel of experts related to a particular problem area is prepared and are kept apart and their identity is kept secret from one another.

**Relevance tree method:** The purpose of the relevance tree method is to help the business in determining objectives and predicting ways to attain them.

**Planning:** Planning is the process of deciding in advance what is to be done, who is to do it, how it is to be done and when it is to be done. It is the determination of a course of action to achieve the desired results.

**Principle of flexibility:** Principle of flexibility states that management should be able to change and existing plan because of change in environment without undue cost of delay.

**Principle of navigational change:** This principle requires that managers should periodically check on events and redraw plans to maintain a course towards the desired goal.

**Corporate planning:** Defined as a systematic and comprehensive process of planning taking account of the resources and capability of the organization and the environment within which it has to operate and viewing the organization as a total corporate unit.

**Divisional Planning:** Divisional planning relates to a particular division or department.

## Review Questions

1. "Managerial planning seeks to achieve a coordinated structure of operations". Comment.
2. "Without planning, an enterprise would soon disintegrate, its actions would be as random as leaves scampering before an autumn wind and its employees as confused as ants in an upturned anthill". Elaborate the statement and examine the significance of planning in the managerial process.
3. "Managerial planning is more of a ritual in a fast changing environment". Comment.
4. "Planning is a mere wastage of time and money". Comment.
5. Discuss the causes of ineffectiveness of planning. How can they be cured?
6. What do you understand by planning? What should be done to overcome its limitations?
7. What do you understand by planning premises? What are their different types? How does correct assessment of planning premises help in preparation of reliable plans?
8. Explain various kinds of planning based on time horizon and levels of management.
9. Why is it necessary to determine the time span of managerial planning? How is long-term planning different from short-term planning?
10. What is Planning? State what advantages does planning confer to an organisation?
11. Explain briefly the principle of flexibility and navigational change with regard to managerial planning. Distinguish between short-term planning and long-term planning.
12. Explain the significance of policies in management. Briefly describe the process of policy formulation.
13. What is Business Forecasting? How would you say that scientific forecasting is a must for dependable planning? Describe the main steps in business forecasting.
14. Explain 'planning premises'. List the planning premises, you would have as a manufacturer, of any ONE of the followings: (i) Cement, (ii) Sugar, (iii) Liquor.
15. Discuss briefly the various techniques of forecasting.

## Further Readings

Billy E. Goetz, op. cit.

Cyril L. Hudson., *Business Organization and Operation*, Staples Press.

*General and Industrial Management*, Sir Isaac Pitman & Sons.

George R. Terry., *Principles of Management*, Richard D. Irwin, Inc. Homewood, Illinois.

Harold Koontz., *Cyril O'Donnell and Heinz Wehrich, Management*, McGraw-Hill, Kogakusha Ltd.

Kenneth H. Killen., *Management — A Middle Management Approach*, Houghton Mifflin Co.

*Management Planning and Control.*, McGraw-Hill Book Co.

## ORGANIZING AND ORGANIZATIONAL STRUCTURE LINE AND STAFF CONFLICTS

### LEARNING OBJECTIVES

1. Organization Structure
2. Principles of Organization
3. Span of Management
4. Organization Charts
5. Organization Manuals
7. Forms of Organization Structure

### Introduction

Organization is the backbone of management. Without efficient organization, no management can perform its functions smoothly. Sound organization contributes greatly to the continuity and success of the enterprise. Once A. Carnegie, an American industrialist said, "Take away our factories, take away our trade, our avenues of transportation, our money. Leave nothing but our organization and in four years we shall have re-established ourselves". That shows the significance of managerial skills and organization. However, good organization structure does not by itself produce good performance - just as good constitution does not guarantee great presidents, or good laws a moral society. But a poor organization structure makes good performance impossible, no matter how good the individuals may be. The right organizational structure is the necessary foundation; without it the best performance in all other areas of management will be ineffectual and frustrated.

Sound organization brings about the following advantages:

1. Facilitates attainment of the objectives of the enterprise.
2. Facilitates optimum use of resources and new technological development.
3. Facilitates growth and diversification.
4. Stimulates creativity and innovation.
5. Facilitates effective communication.
6. Encourages better relations between the labour and the management.
7. Increases employees' satisfaction and decreases employee turnover.

### Concept of Organization

The term 'organization' connotes different things to different people. Many writers have attempted to state the nature, characteristics and principles of organization in their own way. For instance, to the sociologist organization means a study of the



interactions of the people, classes, or the hierarchy of an enterprise; to the psychologist organization means an attempt to explain, predict and influence behaviour of individuals in an enterprise; to a top executive it may mean the weaving together of functional components in the best possible combination so that an enterprise can achieve its goals. The word 'organization' is also used widely to connote a group of people and the structure of relationships. In order to clearly understand the nature and characteristics of organization, we shall study it under the following heads:

- (i) Organization as a group of persons;
- (ii) Organization as a structure of relationships;
- (iii) Organization as a function of management; and
- (iv) Organization as a process.

### **Organization as a Group**

Organization is very often viewed as a group of persons contributing their efforts towards certain goals. The evolution of organization dates back to the early stages of human civilization when two or more persons began to cooperate and combine together for fulfilling their basic needs of food, clothing, shelter and protection of life. Organization begins when people combine their efforts for some common purpose. It is a universal truth that an individual is unable to fulfil his needs and desires alone because he lacks strength, ability and resources. So he seeks cooperation of other people who have similarity of goals.

Barnard defined organization as an identifiable group of people contributing their efforts towards the attainment of goals. "An organization comes into existence when there are a number of persons in communication and in relationship to each other and are willing to contribute towards a common endeavour". People form groups or organizations and pool their efforts by defining and dividing various activities, responsibility and authority. As such an organization has the following characteristics:

- (i) It represents cooperative relationships of two or more persons.
- (ii) It is created to achieve certain common objectives.
- (iii) The group members are in a position to communicate with each other.
- (iv) The group lays down rules and regulations to regulate the behaviour of group members.

Communication is the first major characteristic of an organization. An organization comes into existence and then continues because people are in a position to communicate with one another. It is also essential that they are willing to cooperate with one another for the achievement of their goals. They must contribute their efforts voluntarily towards certain objectives. The existence of common objectives is a must, otherwise the members of the group will not be able to stay together for a long time. Lastly, group members lay down the rules and regulations and the formal structure of relationship among themselves. These are necessary for the proper coordination of the efforts of different individuals in the organization.

### **Organization as a Structure of Relationships**

Some people view organization in a very narrow sense by defining it as a framework of duties and responsibilities through which an undertaking functions. "Organization is no more than the framework within which the responsibilities of management of an enterprise are discharged". According to this definition, organization sets up the scope

of activities of the enterprise by laying down the structure of relationships. If organization is merely recognized as a structure, it will be viewed as a static thing used to explain formal relationships. But an organization is a dynamic entity consisting of individuals, means, objectives and relationships among the individuals. An organization is certainly more than a chart. It is the mechanism through which management directs, coordinates and controls the activities of the enterprise.

### Organization as a Function

Organization is one of basic functions of management. It involves the determination and provision of whatever capital, materials, equipment and personnel may be required for the achievement of certain predetermined goals. By performing this function, management brings together human and non-human resources to form a manageable unit (which is also identified as an organization). Thus, organization is a process of integrating and coordinating the efforts of manpower and material resources for the accomplishment of certain objectives. Just as planning is applied to every other managerial functions, the process of organization is also used in every aspect of management. For instance, organization of the planning department is essential for the formulation of plans and policies. Similarly, organization of other managerial functions is also necessary.

### Organization as a Process

Organization is the process of establishing relationships among the members of the enterprise. The relationships are created in terms of authority and responsibility. Each member in the organization is assigned a specific responsibility or duty to perform and is granted the corresponding authority to perform his duty.

According to Louis A. Allen, "Organization involves identification and grouping the activities to be performed and dividing them among the individuals and creating authority and responsibility relationships among them for the accomplishment of organizational objectives".

As a process, organizing is concerned with arranging in a logical and orderly manner all the activities of the organization. It specifies how the duties are to be divided among the departments and the employees. It also creates relationship of one job to the other jobs and lays down the scope or limits of authority and responsibility of each job.

Organizing involves the following steps:

- (i) **Determination of Objectives:** Organization is always related to certain objectives. Therefore, it is essential for the management to identify the objectives before starting any activity. It will help the management in the choice of men and materials with the help of which it can achieve its objectives. Objectives also serve as the guidelines for the management and the workers. They bring about unity of direction in the organization.
- (ii) **Identification and Grouping of Activities:** If the members of the group are to pool their efforts effectively, there must be proper division of the major activities. Each job should be properly classified and grouped. This will enable the people to know what is expected of them as members of the group and will help in avoiding duplication of efforts. For instance, the total activities of an industrial organization may be divided into major functions like production, purchasing, marketing, financing, etc. and each such function is further subdivided into various

jobs. The jobs, then, can be classified and grouped to ensure the effective implementation of the other steps.

- (iii) **Assignment of Duties:** After classifying and grouping the activities into various jobs, they should be allotted to the individuals so that there are round pegs in round holes. Each individual should be given a specific job to do according to his ability and made responsible for that. He should also be given the adequate authority to do the job assigned to him.
- (iv) **Developing Authority-Responsibility Relationships:** Since so many individuals work in the same organization, it is the responsibility of management to lay down structure of relationships in the organization. Everybody should clearly know to whom he is accountable. This will help in the smooth working of the enterprise by facilitating delegation of responsibility and authority.

### Nature of Organization

The nature of organization will be clear by studying the following features:

- (i) **An Organization Connotes Group of Persons:** McFarland has defined organization as an identifiable group of people contributing their efforts towards the attainment of goals. People form groups or organization to accomplish common objectives and pool their efforts by defining and dividing various activities, responsibility and authority.
- (ii) **Communication is the nervous system of organization:** The organizational members are able to communicate with each other and they coordinate their activities. No organization can survive without an efficient system of communication.
- (iii) **Organizing is a Basic Function of Management:** It is essential for the achievement of organizational objectives. Organizing is done in relation to all other functions of management, namely, planning, staffing, directing and controlling and all the areas of business, namely, purchasing, production, marketing, personnel, etc. The organizing function is performed by all the managers.
- (iv) **Organizing is a Continuous Process:** It is not a one step function. Managers are continuously engaged in organizing and reorganizing. The nature of the process or organization has been described by The Haimann as follows. "Organization is a process of defining and grouping the activities of the enterprise and establishing authority relationships among them".
- (v) **Organizing is Always Related to Objectives:** Whether it is organization of the entire enterprise or a part of it, organizing is influenced by objectives. The operations are divided and authority and responsibility are determined to achieve the predetermined objectives.
- (vi) **Organization Connotes a Structure of Relationships:** The structure of relationships created by the management is referred to as 'formal organization'. But an organization also includes the network of social relationships that arise between people working together. Such relationships are known as 'informal organization'. The study of both formal and informal relationships is necessary to understand the nature of any organization.
- (vii) **Organization Involves a Network of Authority and Responsibility Relationships:** Various positions are created and specific tasks are assigned to them. To perform the tasks, each position is delegated adequate authority. Authority and responsibility relationships throughout the organization must be

clearly defined to achieve coordination and to avoid conflicts between individuals and departments.

### Significance of Organization

A sound organization can contribute to the success of an enterprise in many ways. As a matter of fact, it is the backbone of management. It helps the performance of other functions of management like planning, staffing, direction and controlling. Sound organization can help in achieving enterprise objectives in the following ways:

1. ***Clear-cut Authority Relationships:*** Organization structure allocates authority and responsibility. It specifies who is to direct whom and who is accountable for what results. The structure helps an organization member to know what his role is and how it relates to other roles.
2. ***Pattern of Communication:*** Organization structure provides the patterns of communication and coordination. By grouping activities and people, structure facilitates communication between people centered on their job activities. People who have joint problems to solve often need to share information.
3. ***Location of Decision Centres:*** Organization structure determines the location of decision making in the organization. A departmental store, for instance, may follow a structure that leaves pricing, sales promotion and other matters largely up to individual departments to ensure that varied departmental conditions are considered. In contrast, an oil refinery may concentrate on production, scheduling and maintenance decision at top levels to ensure that interdependencies along the flow of work are considered.
4. ***Balancing of Activities:*** Organization structure creates the proper balance and emphasis of activities. Those more critical to the enterprise's success might be placed higher in the organization. Research in a pharmaceutical company, for instance, might be singled out for reporting to the general manager of the managing director of the company. Activities of comparable importance might be given roughly equal levels in the structure to give them equal emphasis.
5. ***Stimulating Creativity:*** Sound organization structure stimulates creative thinking and initiative among organizational members by providing well-defined patterns of authority. Everybody knows the area where he specializes and where his efforts will be appreciated.
6. ***Encouraging Growth:*** An organization structure provides the framework within which an enterprise functions. If it is flexible, it will help in meeting challenges and creating opportunities for growth. A sound organization structure facilitates growth of enterprise by increasing its capacity to handle increased level of activity.
7. ***Making Use of Technological Improvements:*** A sound organization structure which is adaptable to changes can make the best possible use of latest technology. It will modify the existing pattern of authority-responsibility relationships in the wake of technological improvements.

In short, existence of good organization structure is essential for better management. Properly designed organization can help to improve team work and productivity by providing a framework within which the people can work together most effectively. While building the organization structure, it is essential to relate the people to design. The organization structure which has technical excellence may be quite useless for practical purposes because it is not suited to the needs of the people. Thus, an organization structure should be developed according to the needs of the people in the organization.



## Organization Structure

An organization structure denotes the authority and responsibility relationships between the various positions in the organization by showing who reports to whom. It is a set of planned relationships between groups of related functions and between physical factors and personnel required for the achievement of organizational goals.

Organization involves establishing an appropriate structure for the goal seeking activities. The structure of an organization is generally shown on an organization chart or a job-task pyramid. It shows the authority and responsibility relationships between various positions in the organization. It is significant to note that the organization structure is directly related to the attainment of the organization objectives. For instance, if an undertaking is in production line, the dominant element in its organization chart would be manufacturing and assembling. A good organization structure should not be static but dynamic. It should be subject to change from time to time in the light of the changes in the business environment.

### Developing the Organization Structure

There are two types of structural variables, namely, basic structure and operating mechanism. Designing of basic structure involved such central issues as how the work of the organization will be divided and assigned among positions, groups, departments, divisions, etc. and how the coordination necessary to achieve organizational objectives will be brought about. But operating mechanism, on the other hand, includes such factors as information system, control procedures, rules and regulations, system of reward and punishment, etc.

The development of organization structure deals with two facts, namely (i) the functions which are to be performed and (ii) the form of structure. The first fact requires the determination of activities, the organization needs and division of these activities keeping in mind degree of specialization it can afford. The second fact, i.e., form of structure, requires a detailed study and application of many organizational principles and practices.

Organization structure establishes formal relationships among various positions in the enterprise. The formal relations may be classified into the following categories:

- (i) Relations between the senior and the subordinates and vice-versa;
- (ii) Relations between the specialist position and the line positions;
- (iii) Staff relations; and
- (iv) Lateral relations.

### Differentiation and Integration of Activities

Differentiation and integration of activities relationships are very important considerations in organization designing. Differentiation may be defined as the differences in cognitive and emotional orientation among managers in different functional departments and the differences in formal structure among these departments. Integration, on the other hand, refers to the quality of the state of collaboration that is required to achieve unity of effort. System approach suggests that since various departments are integral part of the whole system, they should not be considered in isolation of others. But since each department is interacting with the environment in a different way, various departments are likely to develop some degree of differentiation depending upon the nature of environment. Therefore, designing of structure of one



department may be different from that of the other. But the overall objective of organizational designing should be integration of activities and authority roles and relationships existing in different departments.

### Determining the Kind of Structure

Organization structure is an indispensable means towards business objectives. Wrong structure will seriously deter the enterprise from achieving its objectives. Thus, it is essential that a great deal of care should be taken while determining the organization structure. Peter Drucker has suggested three specific ways to find out what kind of structure is needed to attain the objectives of a specific business, which are discussed below.

1. **Activities Analysis:** It is the first stage in building an organization structure which involves finding out what activities are needed to attain the objectives of the enterprise. Each business undertaking has a set of functions to perform such as manufacturing, purchasing, marketing, personnel, accounting, etc. These functions can be identified after proper analysis. It may be pointed out that in every organization, one or two functional areas of business dominate. For instance, printing is an important function of a printing firm and designing is an important activity of the readymade garments manufacturer.

After the activities have been identified and classified into functional areas, they should be listed in the order of importance. It is advisable to divide and subdivide the whole work into smaller homogeneous units so that the same may be assigned to different individuals. For instance, the Chief Executive may divide the whole activities into various functional departments and delegate authority to the departmental managers. The departmental managers may be assisted by deputy managers, deputy managers by assistant managers and so on. It should be remembered that the job constitutes the basic building block in designing an organization structure.

2. **Decision Analysis:** What decisions are needed to obtain the performance necessary to attain objectives? What kind of decisions are they? On what level of the organization should they be made? What activities are involved in or affected by them? Which managers must therefore participate in the decisions? Though, it is difficult to predict the content (kind) of decision problems which will arise in future, yet the subject-matter has a high degree of predictability. Analysis of the foreseeable decisions shows the structure of top management the enterprise needs and the nature of authority and responsibility different levels of operating management should have.

Peter Drucker has emphasized four basic characteristics, viz., (i) the decision degree of futurity in the decision; (ii) the impact that decision has on other functions; (iii) the character of the decision as determined by a number of qualitative factors, such as basic principles of conduct, ethical values, social and political beliefs, etc.; and (iv) whether the decisions are periodically recurrent or rare as recurrent decision may require general guidelines whereas a rare decision is to be treated as a distinctive event.

3. **Relations Analysis:** With whom will a manager-in-charge of an activity have to work? Such other questions of relation, e.g., line and staff relations, between subordinates and superior will also help in deciding the structure of the organization. As said earlier, downward, upward and sideways relations must be analyzed to determine the organization structure.

## Principles of Organization

As a tool of management, organization is expected to facilitate the achievement of certain objectives. In order to facilitate the achievement of objectives, management thinkers have laid down certain statements from time to time, from certain generally accepted understandings which may be called the principles of organization. The principles are guidelines for planning an efficient organization structure. Therefore, a thorough understanding of the principles of organization is essential for good organization. The important principles of organization are discussed below:

1. **Consideration of Objectives:** An enterprise strives to accomplish certain objectives. Organization serves as a tool to attain these objectives. The objectives must be stated in clear terms as they play an important role in determining the type of structure which should be developed. The principle of consideration of objectives states that only after the objectives have been stated, an organization structure should be developed to achieve them.
2. **Division of Work and Specialization:** The entire work in the organization should be divided into various parts so that every individual is confined to the performance of single job, as far as possible, according to his ability and aptitudes. This is also called the principle of specialization. More a person continues on a particular job, the better will be his performance.
3. **Definition of Jobs:** Every position in the organization should be clearly defined in relation to other positions in the organization. The duties and responsibilities assigned to every position and its relationship with other positions should be clearly defined so that there may not be any overlapping of functions.
4. **Separation of Line and Staff Functions:** Whenever possible, line functions should be separated from staff activities. Line functions are those which accomplish the main objectives of the company. In many manufacturing companies, the manufacturing and marketing departments are considered to be accomplishing the main objectives of the business and so are called the line functions and other functions like personnel, plant maintenance, financing and legal are considered as staff functions.
5. **Chain of Command:** There must be clear lines of authority running from the top to the bottom of the organization. Authority is the right to decide, direct and coordinate. The organization structure should facilitate delegation of authority. Clarity is achieved through delegation by steps or levels from the top position to the operating level. From the chief executives, a line of authority may proceed to departmental managers, to supervisors or foremen and finally to workers. This chain of command is also known as scalar principle of organization.
6. **Parity of Authority and Responsibility:** Responsibility should always be coupled with corresponding authority. Each subordinate must have sufficient authority to discharge the responsibility entrusted to him. This principle suggests that if a plant manager in a multi-plant organization is held accountable for all activities in his plant, he should not be subject to orders from company headquarters specifying the quantity of raw materials he should buy or from whom he should purchase raw materials. If a supervisor is responsible for the quality of work of his department, he should not be asked to accept as a member of his workforce an employee who has been hired without consulting him.
7. **Unity of Command:** No one in the organization should report to more than one supervisor. Everyone in the organization should know whom he reports and who

reports to him. Stated simply, everyone should have only one boss. Receiving directions from several supervisors may result in confusion, chaos, conflicts and lack of action. So each member of the organization should receive directions from and report to one superior only. This will avoid conflict of command and help in fixing responsibilities.

8. **Exceptional Matters:** This principle requires that organization structure should be so designed that managers are required to go through the exceptional matter only. All the routine decisions should be taken by the subordinates, whereas problems involving unusual matters and policy decisions should be referred to higher levels.
9. **Span of Supervision:** The span of supervision means the number of persons a manager or a supervisor can direct. If too less number of employees are reporting to a supervision, his time will not be utilised properly. But, on the other hand, there is a limit to the number of subordinates that can be efficiently supervised by an executive. Both these points should be kept in mind while grouping and allocating the activities to various departments. It is difficult to give a definite number of persons a manager can direct. It will depend upon the nature of the work and a number of other factors.
10. **Balance of Various Factors:** There should be proper balance in the formal structure of the organization in regard to factors having conflicting claims, e.g., between centralization and decentralization, span of supervision and lines of communication and authority allocated to departments and personnel at various levels.
11. **Communications:** A good communication network is essential to achieve the objectives of an organization. No doubt the line of authority provides readymade channels of communication downward and upward, still some blocks in communication occur in many organizations. The confidence of superior in his subordinates and two-way communication are the factors that unite an organization into effectively operating system.
12. **Flexibility:** The organization structure should be flexible so that it can be easily and economically adapted to the changes in the nature of business as well as technical innovations. Flexibility of organization structure ensures the ability to change with the environment before something serious may occur. So the organization structure should be such that it permits expansion and contraction without disrupting the basic activities.
13. **Continuity:** Change is the law of nature. Many changes take place outside the organization. These changes must be reflected in the organization. For this, the form of organization structure must be able to serve the enterprise and to attain its objectives for a long period of time.

## Span of Management

The term 'span of management' is also known as 'span of control', 'span of supervision' and 'span of authority'. It represents a numerical limit of 'subordinates to be supervised and controlled by a manager. It is an important principle of sound organization. This principle is based on the theory of relationships propounded by V.A. Graicunas, a French management consultant. Graicunas analyzed superior-subordinate relationship and developed a mathematical formula based on the geometric increase in complexities of managing as the number of subordinates increases.

## Graicunas' Theory

Graicunas showed mathematically that a number of direct, group and cross relationships exist between a manager and his subordinates. The number of these relationships increase with the increase in the number of the subordinates. He said that an executive having four subordinates under him is required to deal with (i) 4 direct single relationships, (ii) 12 cross relationships and (iii) 28 group relationships, i.e., in all forty-four relationships. He derived these on the basis of the following formula:

$$\begin{aligned} \text{No. of direct relationships} &= n \\ \text{No. of cross relationships} &= n [n - 1] \\ \text{No. of group relationships} &= n [2n - 1 - 1] \\ \text{Total No. of relationships} &= n [2n/2 + (n - 1) \text{ or } n [2n - + n - 1] \end{aligned}$$

Where n represents the number of subordinates.

The last formula reveals that possible relationships with variable number of subordinates rise very rapidly as shown in the following table:

**Table 1: Possible Relationships with Variable Number of Subordinates**

No. of Subordinates	No. of Relationships
1	1
2	6
3	18
4	44
5	100
6	222
7	490
8	1,080
9	2,376
10	5,210
12	24,708
18	23,59,602

Though, Graicunas gave mathematical formulae for finding out the number of relationships, his approach suffers from various shortcomings, such as ignoring the importance of relationships, frequency of relationships and the factors which determine the span. Moreover, he left out certain possible relationships, particularly in cross relationships. However, his theory gives an important indication that an executive must think twice before increasing his span because increase of one subordinate will increase relationships manifold. Graicunas suggested that an executive can effectively manage 222 relationships which arise out of six subordinates. However, he failed to list factors which govern the span of supervision in practice.

Span of control refers to the number of subordinates an executive can supervise. The concept is central to the classical theory of organization. Proper span of control is considered a necessity for effective coordination. The view in the traditional theory has been that a small span is better than a large one because an executive must have intimate and direct contact with his subordinates. The ideal ratio was considered to be 15 to 25 subordinates for first level supervision and 5 to 8 subordinates in executive spans.

## Impact of span of Supervision

The number of persons an executive supervises has an important influence on the nature of organization structure. If the span is large, it means that fewer levels are needed in the organization. The structure would tend to be flat and wide. Presumably the possibility of communication blockages would be minimized because more people

report directly to the top executive. If the span is small, the structure would be narrow and deep. There would be more levels in the organization. More people will have to communicate to the top manager through intervening layer of executives. The possibility of communication blockages and distortions would increase.

For instance, if there are 256 persons in an organization and all are reporting to one executive, there will be one level of management. If it is thought that only four subordinates should directly report to the chief executive, then the number of management levels will increase to two as four executives directly report to the top executive and each executive controls 64 persons as shown in Figure 1. This structure is flat as the span of control is very large at the lowest level and there are only two layers of management. If it is thought that an executive can manage only 4 subordinates effectively, the number of managerial levels will increase to four as shown in Figure 2. This will make the organization structure look like a tall pyramid.

**Wide Span of supervision:** When the span of supervision is wider, the number of executives needed to supervise the workers will be less. This will make the organization

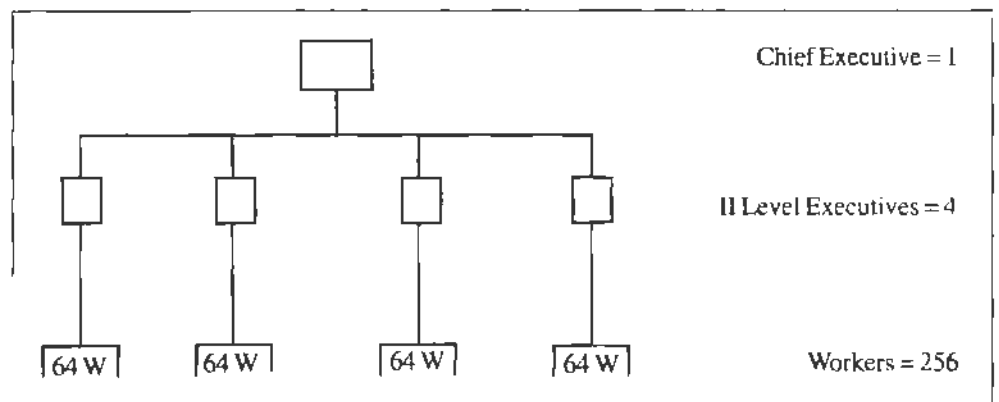

Figure 1: Flat structure (Span of control = 64 workers)

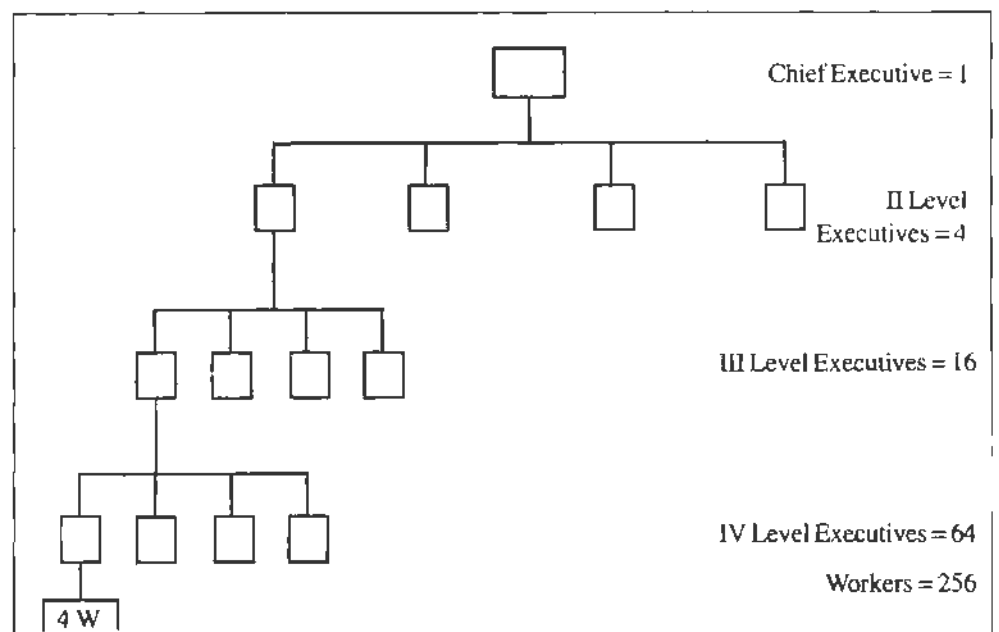

Figure 2: Tall structure (Span of control = 4 workers)



structure wide. Such a structure would be less expensive because of less overhead costs of supervision. Since the number of levels is less, there will be better communication between the worker and the management and better coordination. However, the quality of performance is likely to deteriorate because one executive cannot effectively supervise a large number of subordinates. He will not be able to devote sufficient time in directing each and every subordinate.

**Narrow Span of Supervision:** The narrow span of supervision will lead to a tall structure and to an increase in the executive payroll as compared to the flat structure. Another drawback is that the additional layers of supervision will complicate communication from the chief executive down to operative employees and back up the line. There will also be a problem of effective coordination of the activities of different persons in the organization because of more levels of executives. However, the narrow span of supervision has the benefit of better personal contacts between the supervisors and the subordinates. It facilitates tight control and close supervision. Tall organization structure gives sufficient time to an executive for developing relations with the subordinates.

In recent years, there has been a controversy about the significance of the concept of span of control. The transformation in the style of decision making has had an inevitable bearing on question relating to the number of people an executive can supervise. Moreover, the use of delegation and decentralization is highly advocated these days. It is realized that narrow span of control is an effective means of forcing the executives to delegate. It is also argued that if an executive has enough number of subordinates to supervise. Moreover, the use of delegation and decentralization is highly advocated these days. It is realized that narrow span of control is an effective means of forcing the executives to delegate. It is also argued that if an executive has enough number of subordinates to supervise, there is a point beyond which intimate control becomes very difficult. But how this point should be determined is the main question.

### Factors Determining Span of Supervision

The span of control varies from individual to individual, time to time and place to place. The factors which determine the span of control are discussed below:

1. **Ability of the Managers:** Individuals differ in various qualities like leadership, decision making and communication. The span may be wider if the manager possesses these skills in greater degree as compared to others.
2. **Time available for Supervision:** The span should be narrow at the higher levels because top managers have less time available for supervision. They have to devote the major portion of their time to planning, organizing, directing and controlling. Each top manager will delegate the task of supervision to his subordinates who have to devote comparatively less time on the important functions of management.
3. **Nature of Work:** When the spans are narrowed, the levels in the organization increase. This involves delegation of authority and responsibility. If the work is of a routine and repetitive nature, it can easily be delegated to the subordinates.
4. **Capacity of Subordinates:** If the subordinates are skilled, efficient and knowledgeable, they will require less supervision. In such a case, the superior may go in for a wider span.
5. **Degree of Decentralization:** Under decentralization, the power to make decisions is delegated to the lower levels. The span of management will be narrow in such cases so as to exercise more and more control.

6. **Effectiveness of Communication:** An effective system of communication in the organization favours large number of levels because there will be no difficulty in transmission of information in spite of a large number of intervening layers.
7. **Control Mechanism:** The span of control also depends upon the control mechanism being followed. Control may be followed either through personal supervision or through reporting. The former favours narrow span and the latter favours a wide span.

To sum up, it can be said that an executive should be expected to supervise a reasonable number of subordinates. What is reasonable depends on a variety of factors like individual differences in executives, number and capacity of subordinates, the nature of work, availability of time, ease of communication, internal checks and controls and degree of delegation in the organization. If the span of control is narrow, there will be more organizational levels, which in turn may impede communication. If the number of levels is reduced and the span of control is widened, the supervisory load may become too heavy. Sound management requires a proper balance between supervisory load and organization levels.

## Organization Charts

An organization chart is a diagrammatical form which shows important aspects of an organization including the major functions and their respective relationships. In other words, it is a graphic portrayal of positions in the enterprise and the formal lines of communication among them. It provides a bird's eye view of the relationships between different departments or divisions of an enterprise as well as the relationships between the executives and subordinates at various levels. It enables each executive and employee to understand his position in the organization and to know to whom he is accountable. Thus, it is obvious that an organization chart has the following characteristics:

1. It is a diagrammatical presentation.
2. It shows principal lines of authority in the organization.
3. It shows the interplay of various functions and relationships.
4. It indicates the channels of communication.

The organization chart should not be confused with the organization structure. An organization chart is merely a type of record showing the formal organizational relationships which management intends should prevail. It is, therefore, primarily a technique of presentation. It presents diagrammatically the lines of authority and responsibility among different individuals and positions. It may be either personnel or functional. Personnel organization chart depicts the relationships between positions held by different persons. Functional organization chart depicts the functions or activities of each unit and sub-unit in the organization.

**Master and Supplementary Charts:** Master chart shows the whole structure of the enterprise portraying all positions and relationships. It provides a clear picture of the entire organization structure. Supplementary charts are used to show separately department wise structure portraying the positions and relationships within each department. Such charts are popular in big organization where it is difficult to show the necessary details through the master chart.

**Advantages of Organization Chart:** The advantages of an organization chart are as follows:

- (i) It is tool of administration to tell the employees how their positions fit into the total organization and how they relate to others.
- (ii) It shows at a glance the lines of authority and responsibility. It is a reliable blueprint of how the positions are arranged. From it, the individuals can sense the limits of their authority and can see who their associates are, to whom they report and from whom they get instructions.
- (iii) It serves as a valuable guide to the new personnel in understanding the organization and for their training.
- (iv) It provides a framework of personnel classification and evaluation systems.
- (v) It plays a significant part in organization improvement by pointing out inconsistencies and deficiencies in certain relationships. When management sees how its organization structure actually looks, it may discover some unintended relationships.

**Limitations of Organization Chart:** While the organization chart is an important tool of management, its mere existence does not ensure effective organization because of the following limitations:

- (i) Organization chart shows only the formal relationships and fails to show the informal relations within the organization. In modern enterprises, informal relationships exert important influence on various decisions.
- (ii) It shows the lines of authority, but is not able to answer the questions like how much authority can be exercised by a particular executive, how far he is responsible for his functions and to what extent he is accountable.
- (iii) It shows a static state of affairs and does not represent flexibility which usually exists in the structure of a dynamic organization.
- (iv) It introduces rigidity in the relationships. Updating is not possible without disturbing the entire setup.
- (v) Faulty organization chart may cause confusion and misunderstanding among the organizational members. Moreover, it gives rise to a feeling of superiority and inferiority which causes conflicts in the organization.
- (vi) It does not show the relationships which exist actually in the organization but shows only the 'supposed to' relationships.

Despite these limitations, an organization chart is a must for all enterprises. It can serve as a useful tool of management. It is a reliable blueprint of how positions are related to each other. It shows the employees how their positions fit into the organization and how they relate to others. It is a must to create a proper understanding about the organization structure.

### **Types of Organization Charts**

There are three types of organization charts, viz., (a) Vertical, i.e., from top down; (b) Horizontal, i.e., from left to right; and (c) Circular or concentric. These are briefly discussed below:

- (a) **Vertical Chart:** Most organizations use this type of chart which presents the different levels of organization in the form of a pyramid with senior executive at

the top of the chart and successive levels of management depicted vertically below that. Thus, lines of command proceed from top to bottom in vertical lines as shown in Figure 3.

- (b) **Horizontal Chart:** Horizontal charts which read from left to right are occasionally used. The pyramid lies horizontally instead of standing in the vertical position. The line of command proceeds horizontally, i.e., from left to right showing top level at the left and each successive level extending to the right as shown in Figure 4. However, this chart does not decrease the importance of levels. But it is feared that some people may make erroneous inferences about differences in status and importance of various echelons.
- (c) **Circular Chart:** In this chart, top positions are located in the centre of the concentric circle. Positions of successive echelons extend in all directions outward from the centre. Positions of equal status lie at the same distance from the centre on the same concentric circle. This chart shows the flow of formal authority from the chief executive in many directions. The main weakness of this chart is that it is often confusing.

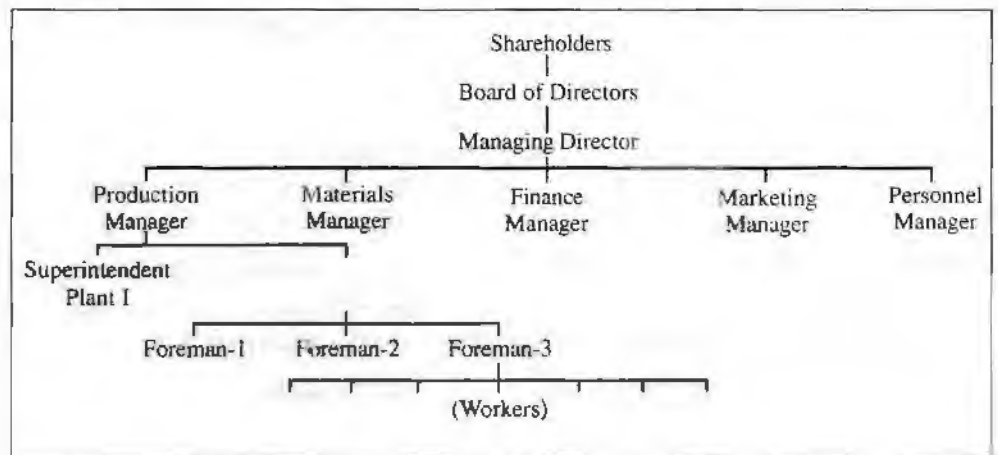

Figure 3: Vertical Chart

## Organization Manuals

An organization chart shows who has authority over whom, but it does not show the extent of authority or the duties each person in the organization is expected to perform, except in so far as duties are implied by job titles. For this reason, big undertakings prepare organization manuals that include job descriptions and other information in addition to the charts. A job description includes factual statements of job contents in terms of its duties and responsibilities.

An Organization Manual is an authoritative guide to the company's organization. It consists of records of top management decisions, standard practices and procedures and the descriptions of various jobs. It is maintained in a loose leaf book from for the guidance of the personnel of the company. If the employees are not supplied with this information adequately, they will approach their superiors for proper information and guidance, causing interruption of work and resulting in wastage of superior's time and energy along with their own time.

## Types of Manuals

Manuals may be classified under a variety of headings, some of which are: (1) policy manual, (2) operations manual, (3) organization manual, (4) rules and regulation manual and (5) departmental manual. These are discussed below:

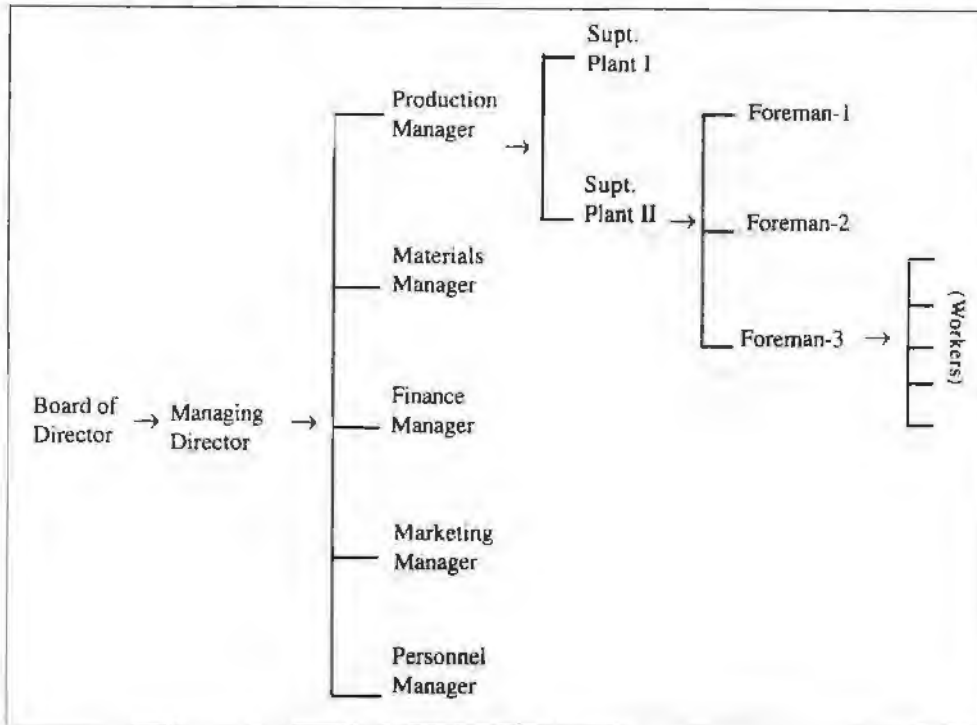

Figure 4: Horizontal chart

1. **Policy Manual:** It is prepared to state the policies of the enterprise. It is a basic guide to action. Policy manual describes the overall limitations within which activities are to take place and thus reveals the broad courses of managerial action likely to take place under certain conditions. It, as a matter of fact, contains decisions, resolutions and pronouncements of the management of the enterprise. Policy manuals are very helpful for providing the framework on which all actions are based.
2. **Operations Manual:** It is prepared to inform the employees of established methods, procedures and standards of doing the various kinds of work. It lists the authorized steps and supplements them by the use of diagrams, sketches, charts, etc. Such a manual gives an overview of the procedures to be used in each of the various departments and divisions.
3. **Organization Manual:** It explain the organization, the duties and responsibilities of various departments and their respective subdivisions. It may consist of portrayal of the formal chain of responsibilities and authorities among different persons working in the enterprise. The level of authority and responsibility of each executive is indicated in the manual so as to avoid conflict in the organization in future. Promotional charts may be included in the organization manual which will show possible promotional lines throughout the entire organization.
4. **Rules and Regulations Manual:** It gives concise information about the operating rules and employment regulations. It may also explain to employees various



benefit plans including group insurance, hospitalization and credit facilities. It prescribes the rules regarding the use of library, cafeteria, recreation club, etc. It also gives the regulations like hour of work, timings, procedure for taking leaves, etc. It is actually a handbook of employment rules.

5. **Departmental Practice Manual:** It contain procedures for a particular department. It deals in detail with the internal policies, organization and procedures of one department. It shows with the help of charts and diagrams the inter-departmental relationships. For instance, the Filing Manual will contain the organization of Filing Department, responsibilities of various jobs, relationships between the employees and the standard procedures for doing the different operations. Similarly, other departments may have such manuals.

**Advantages of Manual:** A manual can lead to the following benefits:

1. It contains, in written form, all important decisions relating to internal organization of the enterprise.
2. It contains rules and regulations and various instructions in a written form. These need not be explained to the employees time and again.
3. It avoids jurisdictional conflicts by avoiding overlapping of authority. The sources of authority are also clear.
4. It enables the new employees to know the various procedures and practices in the shortest possible time. They can know the responsibilities of their jobs and their relationships with other jobs.
5. It enables quick decisions as instructions and policies are stated in definite words.

**Drawbacks of Manual:** A manual may suffer from the following limitations:

1. Small enterprises cannot afford to have a manual because its preparation is a costly and time consuming process.
2. Manual may bring rigidity in the organization by putting the standardized procedures and practices in writing. It leaves little scope of individual's initiative and discretion.
3. Manual may put on record those relationships which no one would like to see exposed.

### **Preparation of Manual**

The organization manual is prepared by the experts who have the detailed knowledge about the organization. The experts should clearly know the objectives of preparing the manual before collecting the information for putting in the manual. Usually, the companies want that the manual should cover a wide range of information. In such cases, it is advisable to carefully arrange the information in some logical fashion. An organization manual may be divided into three parts, viz., (i) Introductory; (ii) Administrative; and (iii) Procedural.

The introductory part contains the following information:

- (a) Nature of the enterprise.
- (b) Objectives of the enterprise.
- (c) Location of the enterprise.
- (d) Organization structure.

The administrative part contains the following information:

- (a) Purpose of the manual.
- (b) Policies of the management.
- (c) Areas of major organizational problems.
- (d) Job descriptions.
- (e) Rules and regulations.
- (f) Organization charts.

The procedural part of the manual contains the following information:

- (a) Instructions relating to the performance of standardized jobs.
- (b) Instructions relating to performance of non-standardized jobs.
- (c) Specimen forms to be used.

The preparation of manuals is too expensive. If no provisions made their revision, their utility will be reduced after any major change. So they must be kept up to date, otherwise employees will not follow such manuals after some time and will discard them. Then the need will be felt of having a new manual and its preparation is very lengthy process. Therefore, revision of the manuals should be made as often as practicable to incorporate the changes that have taken place. If the manuals are in loose-leaf form, new pages with new information may be substituted in place of old ones. In this way, manuals will not remain static. They will undergo change with the changes in the business and its environment.

## Forms of Organization Structure

Organization requires the creation of structural relationship among different departments and the individuals working there for the accomplishment of desired goals. The establishment of formal relationships among the individuals working in the organization and to coordinate the efforts of different individuals in an efficient manner. In order to organize the efforts of individuals, any of the following types of organization structures may be set up: (i) Line organization, (ii) Line and staff organization, (iii) Functional organization, (iv) Committee organization, (v) Project Organization and (vi) Matrix organization. The nature, merits and demerits of these are discussed below.

### Line Organization

The line organization represents the structure in a direct vertical relationship through which authority flows. It is the simplest form of organization structure and is also known as scalar or military organization. Under this, the line of authority flows vertically downward from top to bottom through out the organization. Under this, the line of authority flows vertically downward from top to bottom throughout the organization. The quantum of authority is highest at the top and reduces at each successive level down the hierarchy. Every person in the organization is in the direct chain of command as shown Figure 5.

In line organization, the line of authority consists of an uninterrupted series of authority steps and forms a hierarchical arrangement. The line authority not only becomes the avenue of command to operating personnel, but also provides the channel of communication, coordination and accountability in enterprise.

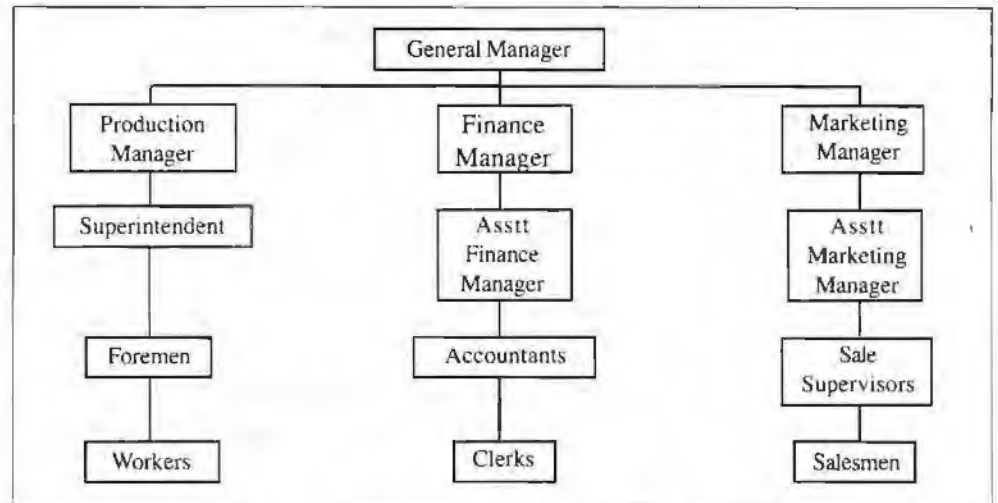

Figure 5: Line organization

### Advantages of Line Organization

The merits of line organization are as follows:

- (i) It is very easy to establish line organization and it can be easily understood by the employees.
- (ii) It facilitates unity of command and thus conforms to the scalar principle of organization.
- (iii) There is clear-cut identification of authority and responsibility relationship. Employees are fully aware of the boundaries of their jobs.
- (iv) It ensures excellent discipline in the enterprise because every individual knows to whom he is responsible.
- (v) It facilitates prompt decision making because there is definite authority at every level. An executive cannot shift his decision making to others, nor can the blame be shifted.

### Disadvantages of Line Organization

The demerits of line organization are as under:

- (i) With growth, the line organization makes the superiors too overloaded with work. If the executives try to keep up with every activity, they are bogged down in myriad details and are unable to pay proper attention to each one. It will hamper their effectiveness.
- (ii) There is concentration of authority at the top. If the top executives are not capable, the enterprise will not be successful.
- (iii) Line organization is not suitable to big organizations because it does not provide specialists in the structure. Many jobs require specialised knowledge to perform them.
- (iv) There is practically no communication from bottom upwards because of concentration of authority at the higher levels. If superiors take a wrong decision, it would be carried out without anybody having the courage to point to its deficiencies.

In spite of these drawbacks, the line organization structure is very popular particularly in small organizations where there are less number or levels of authority and a small number of people. A modification of this structure is line and staff organization under which specialists are attached to line executives to provide them specialised assistance on matters of great importance to the enterprise.

### **Line and Staff Organization**

The line executive is often described as the individual who stands in the primary chain of command and is directly concerned with the accomplishment of primary objectives. Line organization provides decision making authority to the individuals at the top of the organization structure and a channel for the flow of communication through a scalar chain of authority. Line executives are generalists and do not possess specialised knowledge which is a must to tackle complicated problems. With a view to give specialist aid to line executives, staff positions are created throughout the structure. Staff elements bring expert and specialised knowledge to provide advice to line managers so that they may discharge their responsibilities successfully.

In line and staff organization, the line authority remains the same as it does in the line organization. Authority flows top to bottom. The main difference is that specialists are attached to line managers to advise them on important matters. These specialists stand ready with their speciality to serve line men as and when their services are called for to collect information and to give help which will enable the line officials to carry out their activities better. The staff officers do not have any power of command in the organization as they are employed to provide expert advice to the line officers. Staff means a supporting function intended to help the line manager. In most organizations, the use of staff can be traced to the need for help in handling details, gathering data for decision-making and offering advice on specific managerial problems. Staff investigates and supplies information and recommendations to managers who make decisions. Specialised staff positions are created to give counsel and assistance in each specialised field of effort as shown in Figure 6.

Line and staff structure has gained popularity because certain problems of management have become very complex and, in order to deal with them, expert knowledge is necessary which can be provided by the staff officers. For instance, personnel department is established as a staff department to advise the line executives on personnel matters. Similarly, finance, law and public relations departments may be set up to advise on problems related to finance and accounting, law and public relations.

The staff officers do not have any power of command in the organization as they are employed to provide advice to the line officers. In most organizations, the use of staff can be traced to the need for help in handling details, gathering data and offering advice on specific managerial problems.

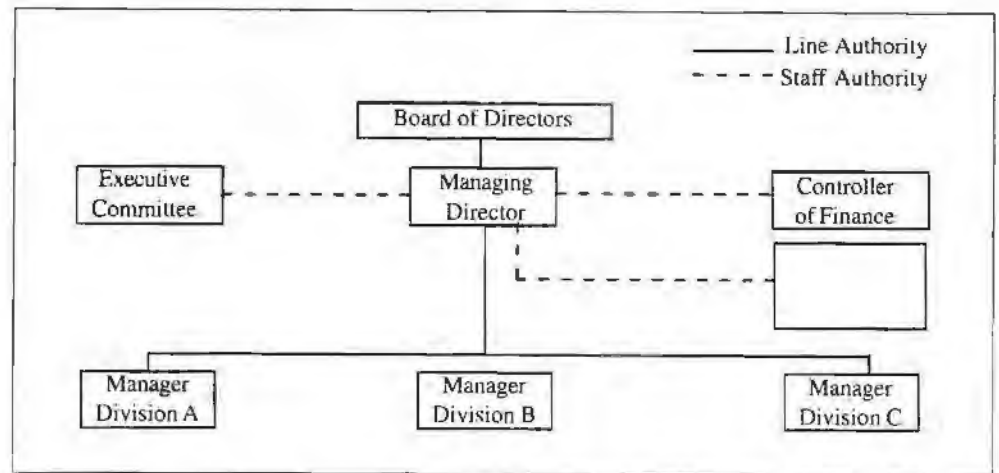

Figure 6: Line and staff organization

### Advantages of Line and Staff Organization

The line and staff organization has the following merits:

- (i) **Specialised Knowledge:** Line managers get the benefit of specialised knowledge of staff specialised at various levels.
- (ii) **Reduction of Burden:** Staff specialists relieve the line managers of the botheration of concentrating on specialised functions like accounting, selection and training, public relations, etc.
- (iii) **Proper Weightage:** Many problems that are ignored or poorly handled in the line organization can be properly covered in the line and staff organization by the use of staff specialists.
- (iv) **Better Decisions:** Staff specialists help the line executives in taking better decisions by providing them with adequate information of right type at the right moment and expert advice.
- (v) **Flexibility:** Line and staff organization is more flexible as compared to the line organization. General staff can be employed to help line managers at various levels.
- (vi) **Unity of Command:** Under this system, the experts provide special guidance without giving orders. It is the line manager who only has got the right to give orders. The result is that enterprise takes advantages of functional organization while maintaining the unity of command, i.e., one subordinate receiving orders from one boss only.

### Demerits of Line and Staff Organization

The line and staff organization suffers from the following drawbacks:

- (i) There is generally a conflict between the line and staff executives. There is a danger that the staff men may encroach on the line authority. Line managers feel that staff specialists do not always give right type of advice and staff officials generally complain that their advice is not properly attended to.
- (ii) The allocation of duties between the line and staff executives is generally not very clear. This may hamper coordination in the organization.



- (iii) Since staff men are not accountable for the results, they may not be performing their duties well.
- (iv) There is a wide difference between the orientation of the line and staff men. Line executives deal with problems in a more practical manner. But staff officials who are specialists in their fields tend to be more theoretical.

### Superiority of Line and Staff Organization over Line Organization

Line and staff organization is considered better than the line organization because of the following reasons:

- (i) Staff makes available expert advice to the line executives. This is necessary to deal with complex problems of management. For instance, personnel department is established as a staff department to advise the top executives and other line executives on personnel matters. Similarly accounts, law and public relations departments may be set up to advise on problems related to accounting, legal issues and public relations.
- (ii) Better decisions are ensured in line and staff organization as compared to a simple line organization.
- (iii) Line and staff structure is more suitable for large organizations as expert advice is always available. The line managers can make use of the knowledge of staff specialists to deal with complicated problems. Therefore, line and staff organization is certainly better than line organization.

Box 1

Line Organization vs Line & Staff Organization	
Line Organization	Line & Staff Organization
1. Line refers to those positions which have the responsibility of achieving the primary objectives of the organization.	1. Staff refers to those positions which have responsibility for providing advice and service to the line in attainment of organizational objectives.
2. There are no experts to assist and advise the line officials.	2. There are experts known as staff to assist and advise the line officials.
3. There is strict discipline.	3. There is loose discipline.
4. There is no scope of friction between line and staff.	4. There is always a risk of friction between line and staff people over their respective roles.
5. It is not based upon planned specialisation.	5. It is based upon planned specialisation.
6. Certain line men become key men as they occupy those positions on which the survival of the organisation depends.	6. This is not possible in case of line and staff organization as staff officials always share credit with line officials.

### Functional Organization

Functional authority occupies a mid-way position between line and staff authority. It is a means of putting the specialists in top positions throughout the enterprise. It confers upon the holder of a functional position a limited power of command over the people of various departments concerning their function. Functional authority remains confined to functional guidance of different departments. It helps in maintaining quality and uniformity of the performance of functional areas throughout the organization.

Under functional organization, various activities of the enterprise are classified according to certain functions like production, marketing, finance, personnel, etc. and

are put under the charge of functional specialists as shown in Figure 7. A functional incharge directs the subordinates throughout the organization in his particular area of business operation. That means that subordinates receive orders and instructions not from one superior but from several functional specialists. In other words, the subordinates are accountable to different functional specialists for the performance of different functions.

It was F.W. Taylor who evolved functional organization for planning and controlling manufacturing operations on the basis of specialization. But in practice, functionalisation is restricted to the top of the organization structure and is not carried down to the lowest level in the organization as recommended by Taylor.

The features of functional organization are as follows:

- (i) The entire organizational activities are divided into specified functions, such as operations, finance, marketing, personnel relations, etc.
- (ii) Each functional area is put under the charge of a functional specialist. The specialist has the authority or right to give orders regarding his function wheresoever that function is performed in the enterprise.
- (iii) If anybody in the enterprise has to take any decision relating to particular function, it has to be in the consultation with the functional specialist.

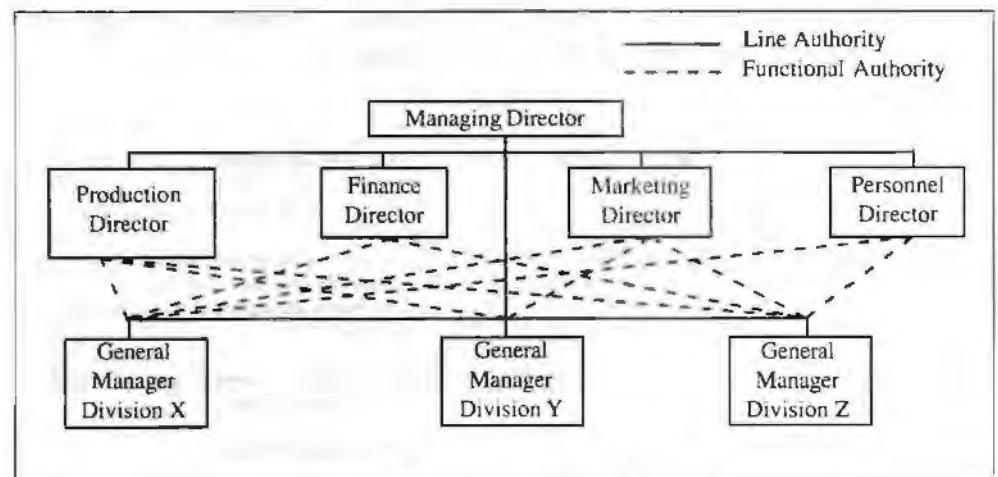

Figure 7: Functional Organization

### Advantages of Functional Organization

The merits of functional organization have been discussed below:

- (i) **Specialization:** Functional organization helps in achieving the benefits of specialization of work. Every functional incharge is an expert in his area and can help the subordinates in better performance in his area.
- (ii) **Executive Development:** A functional manager is required to have expertise in one function only. This makes it easy to develop the executives.
- (iii) **Reduction of Workload:** Functional organization reduces the burden on the top executives. There is joint supervision in the organization. And every functional incharge looks after his functional area only.
- (iv) **Scope for Expansion:** Functional organization offers a greater scope for expansion as compared to line organization. It does not face the problem of limited capabilities of a few line managers.

- (v) **Better Control:** The expert knowledge of the functional manager facilitates better control and supervision in the organization.

### **Demerits of Functional Organization**

The functional organization suffers from the following drawbacks:

- (i) Functional organization violates the principle of unity of command since a person is accountable to a large number of bosses.
- (ii) The operation of functional organization is too complicated to be easily understood by the workers. Workers are supervised by a number of bosses. This creates confusion in the organization.
- (iii) Functional organization develops specialists rather than generalists. This may create problem in succession of top executive positions.
- (iv) A functional manager tends to create boundaries around himself and thinks only in terms of his own department rather than of the whole enterprise. This results in loss of overall perspective in dealing with business problems.
- (v) There is generally a lack of coordination among the functional executives and delay in decision making when a decision problem requires the involvement of more than one specialist.

Jurisdictional conflicts often arise between the line and functional executives. Executives with functional authority sometimes issue instructions directly to personnel throughout the organization. This happens because of failure to define the exact nature of the functional authority which an executive may have. Therefore, it is essential that the functional authority of executives should be clearly laid down. As far as possible, the accountability of subordinates should rest with their line superiors and not with their functional.

### **Taylor's Functional Foremanship**

The functional organization design discussed above is somewhat different from F.W. Taylor's functional foremanship. The structure discussed earlier stands for functionalisation at the top whereas in Taylor's plan, the functional control went down to lowest level in the organization. Taylor felt that one foreman cannot manage the different aspects of production work for directing a group of employees as he cannot have varied knowledge and ability. So he advised the substitution of line authority by functional foremanship at the lower levels of the organization structure.

Taylor recommended that instead of the usual practice of putting one foreman in charge of 10 to 20 workers, there should be the following staff to guide the workers in various functional areas.

- i. Route clerk
- ii. Instruction card clerk
- iii. Time and cost clerk
- iv. Shop disciplinarian
- v. Gang boss
- vi. Speed boss
- vii. Repair boss
- viii. Inspector

There is functional relationship in the structure because every worker is responsible to the speed boss in the matter of discipline and so on. This is the extreme form of functional organization which is not found anywhere because it has been found to be unrealistic and it violates totally the principle of unity of command. In order to maintain unity of command in the organization, functionalisation is applied at the top structure and the functional authority is limited only to the first level that comes below the position of the functional manager.

### **Committee**

Committees, if not one of the poorest forms of organization ever designed, are certainly one of the most maligned. We often come across humorous definitions of committee such as: "A committee is a group of units engaged by their unwillingness to do the unnecessary". "It is a means of passing the buck. It is a group of persons who keep minutes and waste hours". "It is a group of six people – two to do the work, three to pat those two on the back and one to present a minority report". Nevertheless, committees exist in modern organizations because of certain advantages which are discussed later. A committee usually represents a modification in the existing line, line and staff and functional organization structures. It does not replace a significant part of the overall organization structure. It is an aid to the existing organization structure rather than an essential part of it.

### **What is a Committee**

According to Louis A. Allen, "A committee is a body of persons appointed or elected to meet on an organized basis for the consideration of matters brought before it". A committee is a group of persons performing a group task with the object of solving certain problems. The area of operation of a committee is determined by its constitution. A committee may formulate plans, make policy decisions or review the performance of certain units. In some cases, it may only have the power to make recommendations to a designated official. Whatever may be the scope of their activities, committees have come to be recognized as an important instrument in the modern business as well as non-business organizations. They help in taking collective decisions, coordinating the affairs of different departments and meeting communication requirements in the organization.

Committees exist both in business and non-business organizations. It is difficult to give a precise definition of the term 'committee' because there are many different kinds of committees and the concept of committee varies widely from one organization to another. In many organizations, committees contribute an important part of the organization structure. Committees are usually relatively formal bodies with a definite structure. They have their own organization. To them are entrusted definite responsibility and authority. A committee may review budgets, formulate plant for new products or make policy decisions. Or the committee may only have a power to make recommendations and suggestions to a designated official.

Generally, committees are constituted to achieve one or more of the following objectives:

- (i) To have consultation with various persons to secure their viewpoints on different aspects of business.
- (ii) To give participation to various groups of people.
- (iii) To secure cooperation of different departments.

- (iv) To coordinate the functioning of different departments and individuals by bringing about unity of direction.

## Types of Committees

According to the nature of their constitution and functions, committees can be classified as follows:

- (i) **Line and Staff Committees:** If a committee is vested with the authority and responsibility to decide and whose decisions are implemented invariably, it is known as a line committee. For example, board of directors of a company is a line committee of the representatives of its members which is authorized to take and implement policy decisions. On the other hand, if a committee is appointed merely to counsel and advise, it is known as a staff committee. For instance, a committee composed of the heads of various departments may meet at periodical intervals to counsel the chief executive.
- (ii) **Formal and Informal Committees:** When a committee is constituted as a part of the organization structure and has clearcut jurisdiction, it is a formal committee. But an informal committee is formed to advise on certain complicated matters on which the management does not want to set up formal committee which is a costly device. Informal committees do not form part of the organization structure.
- (iii) **Standing and Ad hoc Committees:** Formal committees which are of permanent character are known as standing committees. Ad hoc committees are temporary bodies which may be formal or informal. An adhoc committee is appointed to deal with some special problem and stops functioning after its job is over.
- (iv) **Executive Committee:** It is a committee which has power to administer the affairs of the business.
- (v) **Coordinating Committee:** Such a committee is generally constituted to coordinate the functioning of different departments. It consists of the representatives of different departments who meet periodically to discuss their common problems.

In addition, a business enterprise may have other committees like (a) Finance Committee, (b) Planning Committee, (c) Production Committee, (d) Workers' Welfare Committee and so on.

## Why are Committees Used

A committee almost invariably is used to carry out responsibilities which cannot be undertaken by a single person. Committee have certain inherent advantages because people in group react differently from people as individuals. The advantages or merits are discussed below:

1. **Pooled Knowledge and Experience:** A committee is an effective method of bringing the collective knowledge and experience of a number of persons to solve may intricate problems that are beyond the reach of a single person. In a committee, such members may be taken who are experts in their fields. This will help in concentrating knowledge and judgement of experts for the solution of the intricate problems.
2. **Enforces Participation:** A committee tends to enforce participation by different people in the organization. A major source of resistance to new policies and plans by those who are asked to carry them out is lack of participation on their



part at the planning stage. The management can give representation to the employees in various committee. This will motivate the employees for better performance as they feel that they have a say in the affairs of the organization.

3. **Facilitates Coordination:** When it is necessary to integrate varying points of view, which cannot conveniently be coordinated by individuals, the committee may be used to bring about coordination. A committee consists of representatives of different departments or persons who represent different points of view, who will sit around a table and discuss their common problems. The direct contact among various individuals will bring about proper understanding and coordination in the activities of various departments and individuals.
4. **Overcoming Resistance:** The committee is an important means of cooling off agitation and temper on the part of affected people. Establishment of committee is recognized as strategy for overcoming resistance, opposition or pressure from the affected parties. For purpose of strategy, committees have a wider application in Government, educational, and other non-business institutions.
5. **Check against Misuse of Powers:** It acts as a check and safeguard against the abuse and misuse of powers. Numerous boards and commissions are established by the Governments of all nations to circumscribe the executive authority and to hold it in balance. Even in business, the Board of Directors is a plural executive which reviews the operations of the chief executive of the company. Plural executives in the form of committees are more common in non-business organization than in business organizations.

### Limitations of Committees

Some people consider committee as an organized means of passing the buck. A committee is created when some top people can't make up their minds and they want a committee to do it for them. Though, use of committees brings about certain advantages, they have certain inherent drawbacks also which are discussed below:

1. **Evasion of Decision making Responsibilities:** If a manager has an opportunity to carry a problem to a committee, he may take it as a means of avoiding decision-making or to escape the consequences of an unpopular decision. Thus, managers who want to avoid the laborious and difficult process of logical thinking that leads to a sound decision and to escape responsibility, take resort to committee device.
2. **Slow Decision making:** Committees take more time on procedural matters before any decision is taken. In some cases, slowness seriously handicaps the administration of the organization. The delay in decision making often reduces the usefulness of the decisions. The delay is caused by many factors like giving sufficient membership and lack of preparation before meeting. That is why, committees are sometimes used by managements to cool off agitation by their employees which may create difficulties in the long run.
3. **Costly Device:** Committees are an expensive device both in terms of cost and time. Committee meetings take too much time which absorb the sum total of the salary of its member for that time. Sometimes, committee members deliberately tend to pass time in order to show that they have taken pains in reaching the decision.
4. **Lack of Definite Decision:** When the committee findings represent a compromise of different viewpoints, they may be found to be weak and indecisive.

They may cloud the real issues and get extraneous matters involved in decision making. In case of committee decisions, it is very difficult to fix responsibility on a particular person. So the committee members are apt to be irresponsible and indifferent.

5. **Incompetent Membership:** When a committee is formed, it is implied that the individual members of the committee will exert pressure on the ideas, suggestions, comments and judgements of other members. But this may not happen in practice. The chairman or any strong member of the committee may force the committee to come to a foregone conclusion on the basis of his own thinking and the incompetent members may keep silent. Thus, the decisions may be overshadowed by the force of strong personality.
6. **Source of Misunderstanding:** The committee meetings may prove to be a source of misunderstanding instead of providing a forum for team work and settlement of problems. The chairman of the meeting may not be effective in bringing about reconciliation of ideas of different individuals. Moreover, committee actions are characterized by voting and dissenting practices which may leave behind a legacy of bitterness, discontent and frustration.

### **Making Better Use of Committees**

Notwithstanding the dangers of committees mentioned above, committees are used by most organizations because their advantages far outweigh their disadvantages. Management can make committees a useful agency of administration rather than a doubtful and much bedevilled administrative gimmick. For the successful operation of the committees, the management should keep in mind the following points.

1. **The committee should have a clearly stated purpose:** The purpose should be put in black and white in unambiguous language. This will avoid confusion and wasteful efforts. For clear understanding, the committee members must be specific about the following facts:
  - (i) Functions and scope of the committee.
  - (ii) Responsibilities of the committee.
  - (iii) Authority of the committee.
  - (iv) Organizational relationships.
2. **Members of the committee should be carefully selected:** This is an important factor for the success of the committee. The members must be capable of understanding the real issues entrusted to the committee and taking part in the discussion. As far as practicable, members of the committee should be of similar organizational rank if they are expected to discuss and contribute on an equal basis. The choice of committee members requires a sound judgement as to personality differences, ability in expressions as well as their status.
3. **The committee should be of proper size:** The group should not be too large. If it is too large, many of its members will not have adequate opportunity to express their viewpoints. It may become chaotic if there are many vocal members. But if the group is too small, it is difficult to secure a well rounded viewpoint. The size of committee should depend on the purpose of forming it and the need to give representation to different viewpoints.

4. ***The committee should have a capable chairman:*** The chairman of the committee has to conduct the proceeding of the committee meeting. He should understand his role properly. His job is to encourage others to express themselves, to settle differences and to add a touch of humour when the going is tough. He is an arbiter, a peacemaker and an expeditor. He should not be an advocate of one point of view. His job is to get members of the group think and not to think for them.
5. ***There should be adequate preparation for the committee meeting:*** The major cause of not reaching any decision by the committee is lack of preparation by the committee members and the office. The office should keep all the details ready for use by the committee. The chairman should be provided with adequate clerical and staff assistance so that he can furnish all available factual data for each member before the meeting takes place. The agenda of the meeting and the concerned data, reports and notes should be circulated among the members of the committee well in time so that they get raw material for discussion in the meeting.
6. ***There should be adequate follow up:*** In order to encourage the proper functioning of committees, it is necessary that management should take adequate follow up measures to implement the intent of the committee. Minutes of the committee meeting should be prepared and distributed to each member and also to the top management so that it may evaluate the work done by the committee. This type of control is necessary to avoid committees becoming self-perpetuating or wasting time and delaying decision making.

### Student Activity 1

Select any kind of committee and explain the following:

- (a) Concept of committee
- (b) Name of the committee.
- (c) Type of the committee.
- (d) The reason for forming committee.
- (e) Benefits of forming committee.

### Departmentation

There is a limitation on the number of persons an enterprise can manage directly. This limitation will restrict the size of enterprise if it does not opt for the device of departmentation. Grouping activities and employees into departments makes it possible to expand the activities of enterprise. That is why, departmentation is an integral part of the process of organizing.

### Meaning of Departmentation

A department is a work group combined together for performing certain functions of similar nature. The process of division of the enterprise into different parts is broadly called departmentation or departmentalization. The various parts or divisions go by the name of departments. Departmentation leads to grouping of both functions and personnel who are assigned to carry out allocated functions.

The impact of departmentation is a delineation of executive responsibilities and a grouping of operating activities. Every level in the hierarchy below the apex is departmentalized and each succeeding lower level involves further departmental

differentiation. Grouping of activities into manageable units is necessary at all levels in the enterprise. The chief executive groups activities into major divisions such as production, marketing, finance, etc. These divisions are administered by senior executives who report directly to the chief executive. The senior executives further assign duties to their juniors. For example, the marketing manager may divide his activities on the basis of activities like advertising, marketing research, customer service and so on. At the lower level, there may be sales assistants, sales representatives, etc.

### Objectives and Significance of Departmentation

Objectives of departmentation are to: (i) specialize activities, (ii) simplify managerial tasks and (iii) maintain control by grouping employees within well-defined areas. Departmentation achieves systematic distribution of work among individuals. It facilitates proper supervision and control as the authority for making decisions is diffused to the managers of the departments. This increases the capacity of top management to concentrate on important managerial functions.

The main advantages of departmentalization are as follows:

1. **Increase in Efficiency:** The efficiency of management and enterprise increases because everyone knows precisely his duties and authority. Well-defined jobs and limitations of authority help the individuals achieve better performance.
2. **Fixation of Accountability:** Since jobs are well-defined and responsibilities are clearly mentioned, it is easy to fix accountability for the results.
3. **Development of Managerial Faculties:** Departmentation divides the entire enterprise into various departments. The departmental managers are given the opportunity to take initiative. Departmentation is a training device for them. They can learn new managerial skills which will help them to move higher in the hierarchy.
4. **Performance Appraisal:** Departmentation presupposes the existence of goals or standards of performance. This helps not only in fixing responsibility but also in evaluation of work carried out by an individual or a group or the department as a whole.
5. **Better Control:** Departmentation facilitates better control because standards of performance are well known. Budgets which are one of the control mechanisms can be prepared to control the income and expenditure of different departments. Periodical meetings of the departmental managers can be called to bring units of action in the enterprise.

### Methods of Departmentation

Departmentation is the process which is used to group the activities of the enterprise into various units for the purpose of efficient management. It divides the people and functions comprising an enterprise into various departments to achieve organizational goals. There are certain methods of creating departments in an enterprise which are discussed below:

#### Departmentation By Numbers

Departmentation by simple numbers has been an important method in organization of tribes and armies. It involves placing specific number of undifferentiated persons at the direction of an executive or a manager. The success of such departments depends



upon the quality manpower. This method is not used these days as it is not feasible to achieve the organizational objectives by dividing the entire manpower into certain groups. Labour skills have increased and, moreover, groups composed of persons from different fields are frequently more efficient than those based on mere numbers.

### Departmentation By Function

Under this method, the departments are created on the basis of specified functions to be performed. Activities related to a function are grouped in a single unit with a view to give a well defined direction to the whole group. For instance, in a big enterprise, the major functions like production, purchase, finance, marketing and personnel may be grouped into different departments as shown in Figure 8.

The function shown in the above figure will differ in non-industrial concerns or institutions. For example, in an insurance company, departmentalization may be achieved on the basis of these functions, viz., underwriting agency, claims adjustment and administration. Departmentalization may also go a step further. For instance, the marketing division may be divided into three subdivisions, namely, advertising, selling and marketing research.

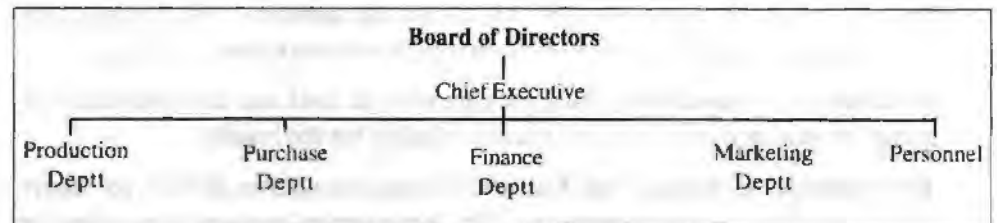

Figure 8: Departmentation of function

Functional departmentation is the most widely employed basis for organizing activities and is present in almost every enterprise at some level in the organization structure as it leads to improved planning and control of the key functions on which the survival and growth of the enterprise depends. Functional specialization leads to better performance in different areas. This type of departmentation is very helpful for the enterprises having a small number of products. It also leads to better results in big organizations producing a large number of products. For instance, activities relating to accounting and finance may be centralized in a separate department and cost and chartered accountants may be employed to provide services to different departments which may even be created on a different basis.

### Departmentation By Product

The grouping of activities on the basis of product or product lines is followed in multi-product large organizations. All the activities related to a particular product line may be grouped together under the direction of a semi-autonomous division manager. Departmentalization by product allows the top management to delegate a divisional manager extensive authority over production, sales, engineering and other functions that relate to a product line as is shown in Figure 9. Within the structure of each of the divisions, line and staff organization may also be used.

Product line is an important basis of departmentation because it creates product divisions each of which could be considered as a viable profit centre for accountability purpose. It places attention and efforts on product lines and fixes responsibility for profits at the



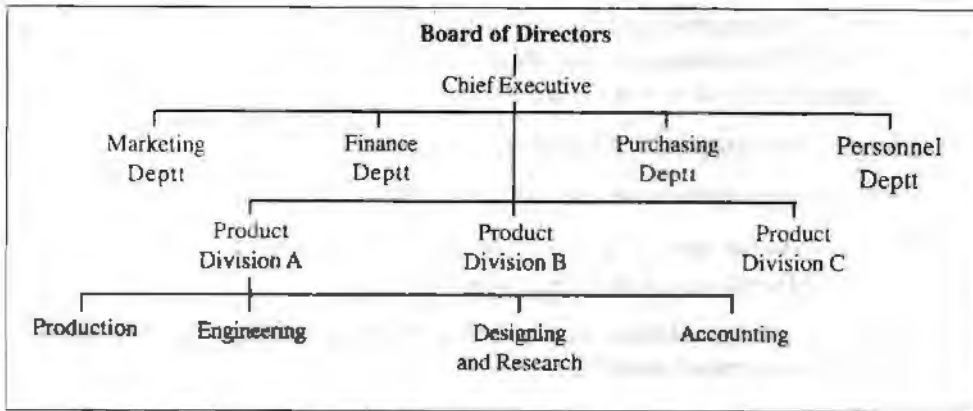

**Figure 9: Departmentation by product**

division level. Since the product divisions are semi-autonomous, it permits growth and diversity of products and services. Market-oriented long range growth strategies can be planned and implemented. The top management can evaluate the performance of different product divisions and pay greater attention to the product line which is less profitable as compared to others. This type of departmentation is useful where it is essential to coordinate the activities relating to a particular product. Besides better coordination, it will also improve customer service.

The advantages of product departmentation are as follows:

- (i) Product departmentation can reduce the coordination problems which are created under functional departmentation. There is integration of activities relating to a particular line of product. It facilitates product expansion and diversification.
- (ii) It focuses individual attention on each product line.
- (iii) It leads to specialization of physical facilities on the basis of products which results in economy.
- (iv) It is easier to evaluate and compare the performance of various product divisions.
- (v) It keeps problems of production isolated from those of others.

Departmentation by products is suitable only for large scale multi-product enterprises which have the capacity to produce and sell on a large scale. If the market of a product line is limited, the management will avoid creating a department for this product as there is duplication of efforts and equipment. Every product division has its own personnel to look after the different areas of the division. The services of certain experts may not be used fully in some departments. The management should resort to this type of departmentation only when it thinks that there will be proper use of personnel and various equipments in different departments. However, there will be problems in allocating overhead costs which are incurred for the entire enterprise.

### **Departmentation By Customer**

Departmentation by customer may be followed in enterprises engaged in providing specialised services to different classes of customers. Under this, customers are the guide for grouping the activities. The management groups the activities on this basis to cater to the requirements of clearly defined customer groups. For instance, a big automobile servicing enterprise may organize its departments as follows: heavy vehicle servicing division, car servicing division, and scooter surviving division. Many educational institutions usually follow this type of departmentation. They offer day courses, evening

courses and correspondence courses to meet the requirements of different types of students. Similarly, marketing organizations may be divided into wholesale, retail and export departments as shown in Figure 10.

The benefits of departmentation based on customers are as follows:

- (i) Customer departmentation can focus on the special customer needs.
- (ii) It focuses on the need to employ personnel with special abilities required for meeting different customer requirements.
- (iii) It leads to greater satisfaction of customers which enhances the reputation of the enterprise among the public.

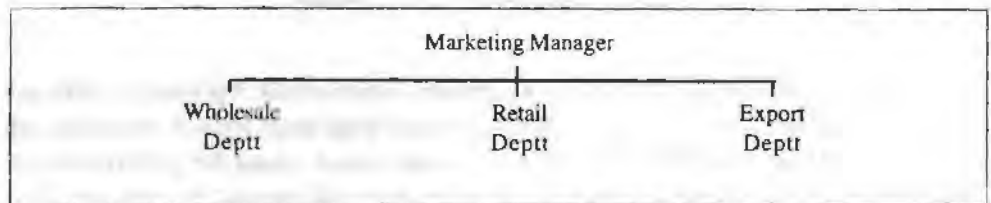

Figure 10: Departmentation based on customers

Customer departmentation is also not free from drawbacks. For instance, it creates the difficulty of coordination between the departments organized on this basis and those organized on other bases. Greater emphasis to the need of the customers may lead to less than optimum use of space, equipment and specialised personnel.

### Departmentation by Territory

Departmentation based on territory or geographical area is often used when several units of an enterprise are geographically dispersed in different locations. Under this, all activities in a given area or territory are grouped together. The best example of such a type of departmentation is that of Indian Railways which is divided into Northern Railways, Western Railways, Southern Railways, Eastern Railways and Central Railways. In business enterprises, this type of departmentation may be followed for production or/and sale in different areas.

Territorial departmentation has the following advantages:

- (i) It helps in achieving the benefits of local operations. The local managers are more conversant with their needs and those of their customers. They can adapt and respond to the local situation with speed and accuracy.
- (ii) A marketing division can meet the demands of various regions more effectively.
- (iii) There is better coordination of activities in a locality through the setting of a regional division.
- (iv) It facilitates the expansion of business in various regions.
- (v) The departments based on territories may function as autonomous units and provide better services to customers.
- (vi) Geographical departmentation enables a big enterprise to disperse its units physically to have advantages of locational factor like availability of raw materials or labour, cheap transport, market and other facilities.

Territorial departmentation may create the problems of coordination among various regional units. Top management which is not conversant with the problems of different areas may not be able to exercise effective control. It will have to depute able personnel to manage various divisions. This will increase the costs of operation. Moreover, the top management will also have some problems in providing economical central services to various divisions which are located at different places.

### Departmentation By Process or Equipment

The departmentation of a manufacturing enterprise having a number of production process may be done on the basis of production process or equipment involved. The manpower and materials are brought together in such a department in order to carry out a particular operation. For instance, production department of a textile mill may be divided on the basis of processes of production, like designing, spinning, weaving, dyeing, bleaching and calendering. A nut bolt manufacturing unit may group similar machines into separate workshops such as lathe machines, drilling machines and grinding machines. This sub-division is also used when the cost of capital equipment is very high. For instance, electronic computer is generally installed in a separate department so that its full use may be made by all other departments.

The advantages of process of departmentation are as under:

- (i) Process of departmentation facilitates coordination by grouping production facilities needed for the completion of each distinct phase of work.
- (ii) It provides for effective utilization of specialised equipments and skills.

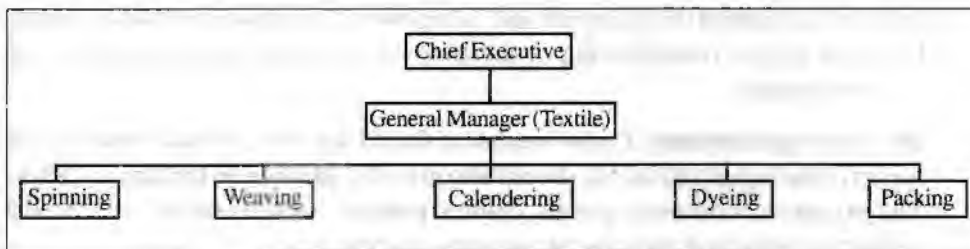

Figure 11: Departmentation based on process

- (iii) It puts full responsibility for the completion of each stage in the production process on the head of the process department.

Process departmentation requires that the volume of activity must be large enough to warrant a separate department. There may be difficulty in the coordination of the departments based on different processes. A breakdown in one process department may hinder the working of all the other process departments which follow the former in sequential workflow. Moreover, inefficient operations in one process department may adversely affect other process departments. There is also a duplication of general purpose equipment in various departments.

### Choice of a Method of Departmentation

We have discussed above the six methods of departmentation which are being used by different organizations. Whatever be the basis, the departmentalization should be directed to promote the attainment of overall organizational objectives. It should simplify coordination and help in achieving economies of specialization. It is significant to point out that in big enterprises no single basis is applied throughout the organization. A

combination of two or three bases is used at different levels in the organization. For instance, a company may adopt functional departmentation at the top, process departmentation in the production function and territorial departmentation in the marketing function and so on.

The choice of basis of departmentation is affected by the following factors:

- (i) **Degree of Specialization:** Specialization helps in raising efficiency and thereby productivity. Top management must create departments on the basis of those methods which facilitate specialization.
- (ii) **Adequate Attention to Key Areas:** Divisionalisation should ensure that sufficient attention is given to the key areas on which the survival and success of the enterprise depends. Separate divisions may be created for all the key areas.
- (iii) **Coordination:** Coordination is said to be the essence of management. The top managers should see that the method of departmentation chosen will ensure proper coordination not only in the departments but also in the entire enterprise.
- (iv) **Control:** The top management must be facilitated to exercise control effectively. The departmentation should not create problems for managerial control. For instance, as an enterprise expands, the functional form of organization becomes difficult to control and other patterns like product departmentation may be adopted.
- (v) **Cost Considerations:** The basis of departmentation chosen must be influenced by cost considerations. For instance, a company may not be in a position to afford departmentation on the basis of territory as it will involve duplication of equipment and manpower. Therefore, cost factor should be given proper consideration at the time of selection of basis or bases of departmentation.
- (vi) **Human Considerations:** Departmentation should not only consider the technical aspect of the organization, but should also give due attention to the human factor. The existence of informal groups, cultural patterns, value systems, etc., should not be lost sight of at the time of grouping the personnel.

### Conclusion

Whatever may be the basis, the departmentation should be directed to promote the attainment of organizational objectives economically and efficiently. Naturally, managers concerned with taking such decisions will consider the relative advantages and disadvantages of various types of departmentation in the light of needs of the organization. In practice, in many cases, it is not feasible to follow a single basis in grouping the activities throughout the organization. Most of the big organizations follow schemes of departmentation that are a composite of several bases as shown in Figure 12. Thus, there is no ideal pattern to suit all occasions and situations. Therefore, the management has to be very careful and use high degree of imagination at the time of choosing a pattern of departmentation. Once a pattern is chosen, it is very difficult and costly to switch over to another pattern.

The most commonly followed basis of departmentation at the top level of the organization is functional departmentation. At the intermediate and lower levels, other bases are used wherever further functionalisation is not feasible.



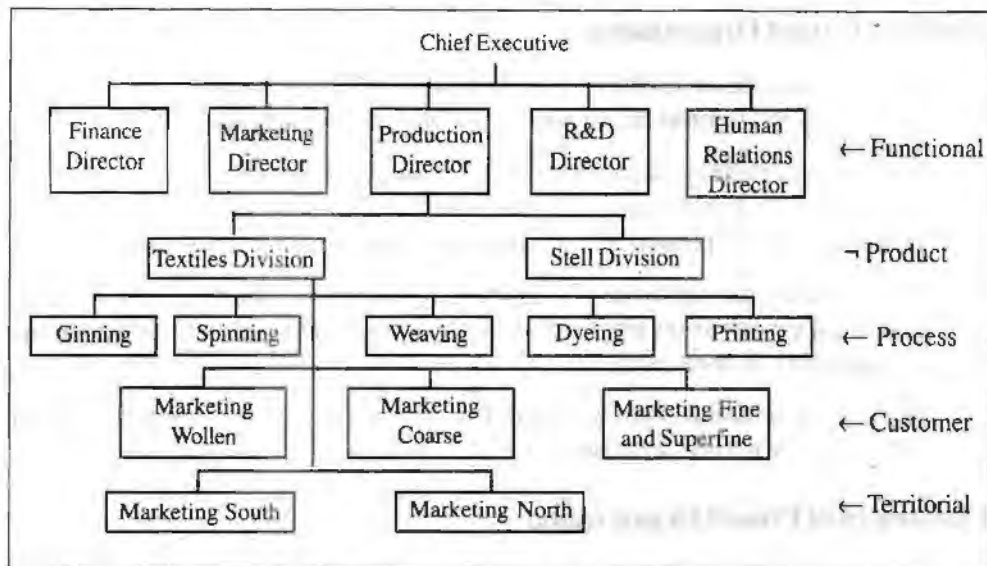

Figure 12: Composite structure

### Project Organization

Project organization is oriented towards the completion of a big project or a small number of big projects. Under this, a team of specialists from different areas is created for each project. Such a team is separate from and independent of functional departments. The size of the project team varies from one project to another. The activities of the project team are coordinated by the project manager who can obtain advice and assistance of experts both inside and outside the organization.

The project organization calls for creating a team of specialists to work on and complete a particular project. It has been developed to deal with situation where production and marketing strategies do not fit into a pure functional organization. Project organization is employed in aero-space, aircraft manufacture, construction and professional areas like management consultancy. In such cases, projects are subject to high standards of performance and there is a strong emphasis on horizontal relation among specialists. In industrial concerns, project teams may be structured to facilitate the designing and development of new products.

The need for project organization is felt when an organization is to execute a project or programme which is subject to high standards of performance as in case of aircraft companies. If the project organization is created for one time project, it will have temporary set up and will be disbanded when the project is completed. However, in practice, it takes a permanent form when the duration of the project is quite long and it may become a regular autonomous project division, functionally organized.

### Suitability of Project Organization

Modern organizations use project structure under the following circumstances:

- (i) The project is a one-time assignment with well-defined specifications and the organization wants to continue concentration on its regular activities.
- (ii) The assignment presents a unique or unfamiliar challenge.
- (iii) Successful completion of the project is critical for the organization.
- (iv) The project must be completed within the given time limit.



### **Merits of Project Organization**

- (i) Project organization facilitates concentrated attention on the complex project. It can be tailored to meet the requirements of a particular project.
- (ii) Project management requires specialists in various fields. Specialists get higher satisfaction while working on complex projects. Thus, project organization allows maximum use of specialised knowledge available with the organization.
- (iii) Project organization provides flexibility in handling specialised projects. It adopts a logical approach to any challenge in the form of a project with definite beginning, end and well-defined result.
- (iv) Project organization facilitates the timely completion of a project without disturbing the normal activities of the organization.

### **Limitations of Project Organization**

- (i) The job of a Project Manager becomes very difficult because of lack of clearly defined responsibility, lack of clear communication pattern and lack of standards of performance for various professionals.
- (ii) Uncertainty in project structure arises because the Project Manager has to deal with specialists from a number of diverse fields. The specialists often have different approaches and interests.
- (iii) Decision making gets highly complicated because there are unusual pressures from specialists from diverse fields. The Project Manager has to devise a decision process where information could be monitored quickly and decisions taken quickly.
- (iv) Motivation of specialists may pose another problem for the Project Manager. Moreover, there may be conflicts among the specialists quite often because of their different orientations.

### **Matrix Organization**

This is one of the latest types of organizational designs which has been developed to establish flexible structure to achieve a series of project objectives. Matrix organization, also known as grid, has been designed as an answer to the growing size and complexity of undertakings which require an organization structure more flexible and technically oriented than the traditional line and staff or functional structure.

Matrix organization is created by merging the two complementary organizations – the project and the functional. It represents a combination of functional and departmental organization. In it, projects cut across the functional lines. The project teams are composed of people from the functional departments who are assigned to the project for a specific period or for the duration of the project. When their assignment is complete, they return to the functional departments to which they belong.

1. Matrix organization is built around a specific project. The charge of the project is given to the project manager, who is given the necessary authority to complete the project in accordance with the time, cost, quality and other conditions communicated to him by the top management.
2. The project manager draws personnel from various functional departments. He assigns work to the various functional groups. Upon completion of the project, the functional groups return to their functional departments for reassignment to

other projects. The project manager himself is also available for reassignment by the divisional manager.

3. In matrix organization, the project and the functional managers have different roles. The project manager follows a general management viewpoint with regard to his project. Each functional manager is responsible for maintaining the integrity of his function. Project managers have to determine:

- (i) What efforts are required to accomplish the given project?
- (ii) When will it be performed?
- (iii) How much is budgeted?

Functional managers determine:

- (i) Who will perform the specific tasks?
- (ii) How will they be accomplished?
- (iii) How well are they accomplished?

The matrix organization structure has been illustrated in Figure 13. The Division X is composed of two projects each with specific objectives and a period of completion. The Division has four functional departments: Production, Engineering, Finance and Personnel which provide functional support to the projects. Each of project organization is composed of a project manager and functional work groups from various functional departments. The project manager achieves the project objectives with the help of the functional group who are assigned back to their respective departments when their assignment is over.

During the continuation of the project, the personnel assigned to the project have two bosses—first of the functional department and second of the concerned project. This violates the principle of unity of command which states that no person in the organization should report to more than one boss. This may create serious problems for the organization. In order to avoid problems, both bosses in the project should determine in advance the exact authority and responsibility each will have during the project's life. With such an arrangement, employees will be receiving orders about a specific subject only from one boss. If this is not done, it will create many human relation problems which are difficult to handle. Therefore, it is essential to demarcate the nature and extent of authority with each boss so that both the supervisors and their subordinates can operate smoothly.

**Suitability of Matrix Organization:** Matrix organization has been developed to meet the needs of large organizations for a structure which is flexible and technically sound. Temporary project teams are deputed for the successful completion of particular projects. For instance, in an industrial organization, chemical, mechanical, industrial and electronic engineers may work together with physicists, accountants and other professionals to develop a new product.

Matrix organization is used in industries with highly complex products as in aerospace industry where project teams are created for specific space or weapon systems. It is also highly useful when an organization has a number of projects ranging from small to large as in case of a construction company.

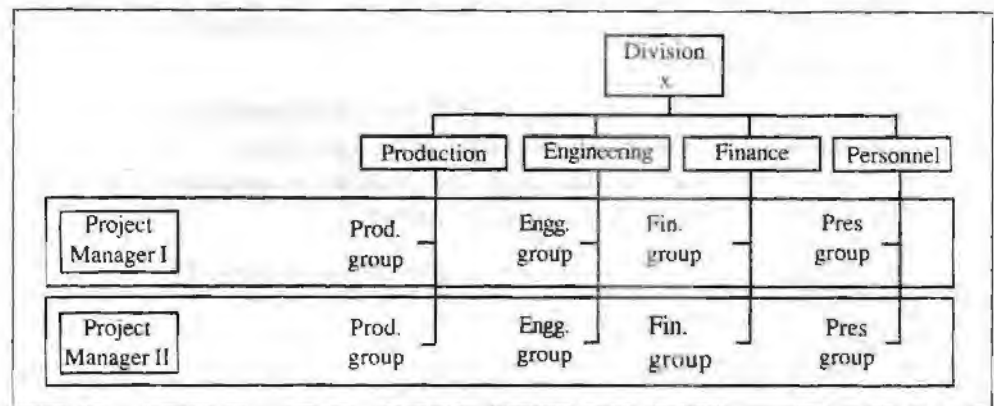

Figure 13: Matrix organization

### Project Organization vs Matrix Organization

There is a difference between the project organization and the matrix organization. In pure project organization, complete responsibility for the project as well as the resources needed for its completion are usually assigned to one person known as Project Manager. In case of a large project, its structure resembles a regular autonomous division. But in a matrix organization, the Project Manager has to share the resources with the rest of the enterprise. In other words, matrix structure requires two lines of authority to exercise shared influence over the same resources. It combines functional departmentation with the project structure. The individuals working on a project under a matrix structure have a continuing dual assignment to the project and their parent (functional) department.

Matrix organization is often desirable when an organization has variety of projects, ranging from small to large as in case of a construction company. But Project organization is employed by companies dealing with one or two big projects. A separate project team is created to handle each project.

### Merits of Matrix Organization

1. It focuses attention on resources of each project separately which facilitates better planning and control. It also helps in completion of projects in time.
2. It is more flexible than the traditional functional organization. It can be applied more usefully to an organization involved in projects ranging from small to large. It can better respond to the changes in technology, market conditions, etc. It can also respond to the needs of the client quickly.
3. Service of professionals are better utilised in case of matrix organization as more emphasis is placed on the authority of knowledge than rank of the individuals in the organizational hierarchy.
4. It provides motivation to the personnel engaged in a project. They can utilize their competence and make maximum contribution for the execution of the project. It also improves communication and coordination by facilitating direct contact between the project manager and the functional groups.
5. Functional departments provide the necessary personnel to each project. The personnel revert back to their parent department after the project is completed. This brings economy in the use of the specialised services of personnel from different functional areas.

## Limitations of Matrix Organization

1. It violates the principle of unity of command as personnel receive orders from the project manager and the functional boss. This may give rise to jurisdictional conflicts in the organization.
2. Apart from formal relationships, informal ones also operate in the matrix organization. Thus, organizational relationships become more complex and they create the problem of coordination.
3. Functional groups generally visualize the significance of their respective functions. This may lead to conflicts between the functional groups.
4. In matrix organization, personnel are drawn temporarily from different departments and the project manager does not have line authority over them. This may lead to lack of commitment to project objectives on the part of personnel. Moreover, morale of the personnel may also be low.
5. Matrix organization can't constitute a homogeneous and compact group. The multiplicity of vertical and horizontal relationships may impair organizational efficiency. The functional experts may try to emphasize their own specialization at the cost of the project because of lack of clarity of jurisdiction of the project and functional managers.
6. Deputation of personnel from functional departments to a number of projects over a period of time makes it difficult for the functional heads to appraise employee performance. It is quite likely that job requirements in projects are different from the jobs in functional departments. In some cases, the personnel may find it difficult to adjust to the requirements of the new project.

## Summary

Information technology revolution has forced the organization to change their traditional structures and many organizations have actually restructured themselves and changed their management styles to take full advantage of the information age. At AT&T from a large number of 1300 business tasks before the introduction of Information Technology applications in its Network Services Division with 16000 employees is now organized around 13 core business processes. Another example of change in the organization structure is of Eastman Kodak Company which has adopted 'Pizza chart' replacing the conventional organizational structure. In the light of the information age, the organizations are redefining the mission, objectives, strategies, critical success factors (CSFs), and restructuring the traditional pyramid type organization structures to the new organization structures like flat, networks, orchestras, spiderwebs, starburst, pizza, etc. Managers must learn to be pro-active in this fast moving world of today.

## Keywords

**Organization:** A group of people and the structure of relationship.

**Organizational structure:** Organizational structure denotes the authority and responsibility relationship between the various positions in the organization by showing who reports to whom.

**Activities Analysis:** First stage in building organization structure which involves finding out what activities are needed to attain the objectives.

**Decision Analysis:** What decisions are needed to obtain the performance necessary to attain objectives.



**Relation Analysis:** With whom will a manager in-charge of an activity have to work.

**Division of work:** The entire work in the organization should be divided into various parts so that every individual is confined to the performance of single job.

**Chain of command:** Line of authority running from the top to the bottom of the organization.

**Unity of Command:** Every one in the organization should report to one supervisor.

**Span of supervision:** The number of persons a manager or a supervisor can direct.

**Span of management:** Also known as 'span of control', 'span of supervision' and 'span of authority'. It represents a numerical limit of subordinates to be supervised and controlled by a manager.

**Graicunas' Theory:** Graicunas proved mathematically that a number of direct group and cross relationships exist between a manager and his subordinates.

**Committee:** A committee is a group of units engaged to solve certain problems.

**Departmentation:** Departmentation leads to grouping of both functions and personnel who are assigned to carry out allocated functions.

**Project Organization:** Project organization is oriented towards the completion of a big project or a small number of big projects.

**Matrix Organization:** It is a combination of functional and departmental organization.

## Review Questions

1. "Sound organization structure is an essential prerequisite of effective management", Comment.
2. "Organization is an important tool to achieve enterprise objectives". Explain this statement.
3. Explain the concept and nature of organization. Narrate, in brief, the steps in organizing.
4. Explain the concept of span of control. What factors influence the span of control in an organization?
5. What is meant by organizing? Explain the principles of organizing.
6. "Sound organization structure is an essential prerequisite of efficient management". Discuss the above statement and point out the various principles while establishing and developing organization structure.
7. Discuss the basic considerations to be kept in view while designing an organization structure. State the usefulness of organization charts in this context.
8. "Organization charts provide a broad picture of positions of authority and their relationships in the organization structure". Discuss and point out the important limitations of organization charts.
9. What do you understand by an organization manual? Discuss the contents it should contain.
10. Why are committees widely used in business management? What limiting factors make them expensive and ineffective? Give suggestions for better use of committees.



11. "A committee as a tool of management is excellent but only a few managers know how to use it". Comment.
12. Define departmentation. What are the basic factors to be considered while creating departments?
13. Suggest a scheme of departmentation for a large business enterprise with a field network of sales all over the country. Discuss its merits and demerits.
14. Rahul Steel and General Industries Ltd has decided to diversify its activities and undertake production of automobiles. The Chief Executive seeks your advice on whether to group the activities by product or by function. What advice would you tender and why?
15. "Project organization is not a panacea for overcoming all functional organization weaknesses. But it can be a great asset to those companies which possess the acumen to exploit its strengths". Indicate the various strengths of a project organization and suggest whether it should complement or supplement or replace the functional organization.
16. Explain the concept of Matrix Organization. How does it differ from Project Organization?

### **Further Readings**

Allen, Louis A., *Management and Organization*, McGraw-Hill.

Allen, Louis A., *Management and Organization*, McGraw-Hill Kogakusha Ltd.

Amitai Etzioni, *Modern Organizations*, Prentice-Hall of India, New Delhi.

Barnard, Chester I., *The Functions of the Executive*, Harvard University Press, Cambridge.

Brech, F.E.L. (ed), *The Principles of Practice of Management*, Longmans, Green & Co.

Chester I. Barnard, *The Functions of the Executive*, Cambridge Harvard University Press.

Dalton E. McFarland, *Management: Foundations and Practices*, New York, Macmillan.

Fred Luthans, *Organizational Behavior*, McGraw-Hill, New York.

## AUTHORITY AND ORGANISATIONAL RELATIONSHIP

### LEARNING OBJECTIVE

1. Authority Relationships: Line, Staff and Functional

### Authority Relationships: Line, Staff and Functional

Within the framework of the formal organization, there are three basic organizational relationships, namely, (i) authority, (ii) responsibility and (iii) accountability. Authority is the right conferred on an individual to make possible the performance of the work assigned. It includes the discretion to make decisions to issue instructions to the subordinates and to use organizational resources. Responsibility means to task or duties assigned to an individual in the organization. Entrustment of responsibility must be associated with the requisite authority for the accomplishment of the task. By accepting authority and responsibility, a subordinate becomes accountable for the use of authority to his boss. These relationships are designated as formal because they are predetermined by the management as a way of relating and combining the diverse functions of the enterprise. This chapter aims at providing an insight into these relationships.

#### Authority

Authority is the right to order or command and is delegated from the superior to the subordinate to discharge his responsibilities. Right to procure or use raw materials, to spend money or ask for the allotment of money, to hire or fire people, etc., has to be delegated to the individuals to whom the work has been assigned. For instance, if the chief executive of a plant assigns the production manager with the production of particular types of goods and service, he should also grant him the authority to use raw materials, money and machinery, hire workers and so on to fulfil the production schedules prescribed as his duty.

Louis A. Allen defined authority as the sum of the powers and rights entrusted to make possible the performance of the work assigned. Authority is basis to the job of managing. A manager must have adequate authority to get things done through the subordinates. The features of managerial authority are as under:

- (i) Authority is the right or power to command and control the subordinates.
- (ii) It is granted to a position (or manager) for the achievement of organizational objectives.
- (iii) The authority may be exercised through persuasion or sanctions. If the subordinate does not obey, the superior has a right to take disciplinary action.

#### Responsibility

The term 'responsibility' means the work or duties assigned to a person by virtue of his position in the organization. The person carrying the responsibility for the

performance of a given task has also the authority to perform it. For instance, if a project manager is responsible for the construction of a bridge, he has also the authority to command his subordinates, procure the needed materials, procure personnel and seek assistance from functional departments for the completion of the project. Responsibility should be distinguished from accountability which is the obligation of an individual to render an account of the fulfillment of his responsibility to the superior to whom he reports.

**Accountability**

Just as responsibility is a derivative of work to be performed and authority is derived from responsibility, accountability, in turn, is a logical derivative of authority. When a subordinate is given an assignment and is granted the necessary authority to complete it, the final phase in basic organization relationship is holding the subordinate responsible for results. In other words, the subordinate undertakes an obligation to complete the assignment by the fair use of authority and account for the discharge of responsibility assigned.

Accountability is the obligation to carry out responsibility and exercise authority in terms of performance standards. For accountability to be effective, the standards of performance should be determined before entrusting a task and should be understood and accepted by the subordinate. The extent of accountability depends upon the extent of authority and responsibility delegated. A person cannot be held answerable for the acts not assigned to him by his superior. Creation of accountability leads to justifying delegation authority to a subordinate.

**Kinds of Authority**

Louis A. Allen has classified authority into three categories namely, (i) Authority of knowledge, (ii) Authority of position, and (iii) Legal authority. According to him authority of knowledge is possessed generally by the staff specialists appointed by the company. They more often influence the actions of persons in line by virtue of their knowledge. Some persons acquire authority by virtue of their position in the organization. Legal authority is the authority which is entrusted to a person by the law of the land. For instance, a company is a legal person and has a right to sue others according to the provisions of the Companies Act.

**BOX 1**

<b>Authority vs Responsibility</b>	
<b>Authority</b>	<b>Responsibility</b>
1. Authority is the right of a manager to command his subordinates and use organizational resources.	1. Responsibility denotes the duties or tasks assigned to a subordinate by his boss.
2. Authority arises because of a formal position in the organization. Whosoever occupies a position, has the right to command the subordinates.	2. Responsibility arises from a superior-subordinate relationship. The subordinate is accountable since he owes an explanation to his superior for the performance of duties assigned.
3. Authority can be delegated to the subordinates.	3. Responsibility i.e., obligation to account for results, can't be delegated.
4. Authority always flows downward from a superior to his subordinate.	4. Accountability always moves in the upward direction as the subordinate is responsible to his superior.

### Sources of Authority

Management scholars are divided on whether authority originates at the top and flows down in traditional fashion or whether it originates at the bottom as a kind of consent of the subordinates. We can classify the views of various management writers under the three headings, namely, formal authority theory, acceptance theory and competence theory. These viewpoints are discussed below:

1. **The Formal Authority Theory:** According to this theory, authority is viewed as originating at the top of an organization hierarchy and flowing downward therein through the process of delegation. The ultimate authority in a company lies with the shareholders who are its owners. The shareholders entrust the management of the company to the Boards of Directors and delegate to it most of their authority. The Board of Directors delegates authority to the Chief Executive and the Chief Executive in turn to the departmental heads and so on. Every manager in the organization has some authority because of his organizational position. That is why, the authority is known as formal authority. Subordinates accept the authority of a superior because of his formal position in the organization. A manager in the organization has only that much of authority which is delegated to him by his superior.

The shareholders of a company have authority over the company because of the institution of private property in the society. Various social factors, laws, political and ethical considerations, and economic factors put certain limits on their authority and the organization has to function within these limits. In fact, the basic sources of authority can rest in the social institutions themselves. In a society, where private property does not exist as in the case of socialist economies, the origin of authority can be traced to the elements of basic group behaviour.

The concept of authority as being a right transmitted from the public through social institutions to business manager is the central theme of the formal authority theory. As shown by a schematic model given below, business and its management are influenced by changes in the country's environment (economic, political, social, educational, etc.) which in turn modify the public norms and attitudes.



Figure 1: Formal authority through social institutions

2. **The Acceptance Theory:** According to this theory, the authority is the power which is accepted by others. Formal authority has no significance unless it is accepted by the subordinates. The degree of effective authority possessed by a manager is measured by the willingness of the subordinates who accept it. "An individual will accept an exercise of authority if the advantages accruing to him from accepting plus the disadvantages accruing to him from not accepting exceed

the advantages accruing to him from not accepting plus the disadvantages accruing to him from accepting; and conversely, he will not accept an exercise of authority if the latter factors exceed the former". Thus, the acceptability of orders may be fully acceptable, may be fully unacceptable and others only partially acceptable. Barnard maintains that a subordinate will accept an order if he understands it will, if he believes it is consistent with the organizational objectives and compatible with his own interest.

**Zone of Indifference:** In addition to the above conditions, acceptance of authority is fostered by what Barnard called, the zone of indifference and Simon referred to as the area of acceptance. The 'zone of indifference' indicates the specific limits that are set by individuals themselves within which they will respond willingly to the exercise of authority over them. In fact, not all orders are obeyed with equal enthusiasm. The zeal or reluctance with which a subordinate carries out an order is the result of his weighing, often subconsciously, the effect which trying to carry out the order will have upon his personal career. Within this zone, the employees will not question the use of authority. But outside this zone, the superiors must earn the acceptance of the employees.

The acceptance theory of authority has certain limitations. According to it, a manager has authority if he gets obedience from the subordinates. But a manager is not able to know whether his order will be obeyed by his subordinates unless the order is carried out or disobeyed by them. Further, the theory emphasizes rewards and punishments a superior can use, but it overlooks the influence of social institutions like trade unions.

3. **The Competence Theory:** According to this theory, an individual derives authority because of his personal competence. Urwick identified formal authority as being conferred by organization, technical authority as being simplicity in a special knowledge or skill, personal authority as being conferred by seniority or popularity. Thus, a person may get his order or advice accepted not because he is having any formal authority, but because of his personal qualities. These qualities may be technical competence and social prestige in the organization. For example, a person is expert in a particular field and other people go to him for guidance and follow his advice as if that were an order.

From the analysis of theories of authority, it can be concluded that acceptance and competence theories suggest how and why an individual obeys the order of another. But the importance of formal authority cannot be undermined. The formal authority should be regarded as basic to managerial job and acceptance and competence authority as products of leadership. In some organizations like army and police, formal position is the most important source of authority.

### Limits of Authority

The authority of an organization is not absolute. It is subject to various economic, social, legal political and other factors. Similarly, the authority of a manager is restricted by various factors such as:

- (i) **Physical Limitations:** Physical laws, climate, geographical factors, etc., restrict managerial authority to a great extent. Thus, an order to make silver from aluminium would be meaningless.
- (ii) **Economic Constraints:** The authority of an executive is restricted by economic constraints. A chief executive would not like to ask his sales personnel to sell products at a high price in a highly competitive market or to ask the purchase



department to procure raw material for use in the next twelve months when capital and storage space are not available for this purpose.

- (iii) **Social Constraints:** The use of managerial authority is also subject to many social limitations. Thus, the task assigned to employees must conform to the group's fundamental social beliefs, values, customs and ethics.
- (iv) **Legal Constraints:** Various acts of the Central and State Governments impose restrictions on the exercise of authority by a manager. For instance, a manager can't ask the workers not to form or join a union.
- (v) **Biological Limitations:** A manager cannot ask a subordinate to do something which he is not capable of doing. For example, a manager cannot task a subordinate to climb the side wall of a building.
- (vi) **Internal Constraints:** A manager's authority is limited by the objectives and policies laid down by the top management of the organization. He can't go against the internal policies and rules of the organization.

### Power

The term 'power' may be defined as the capacity to exert influence over others. If a person has power, it means that he is able to influence the behaviour of other individuals. The essence of power is control over the behaviour of others. "In one's role as a supervisor, a manager's power may be seen as the ability to cause subordinates to do what the manager wishes him to do. A manager's power may be measured in terms of the ability to (1) give rewards, (2) promise rewards, (3) threaten to withdraw current rewards, (4) withdraw current rewards, (5) threaten punishment and (6) punish".

The term 'authority' on the other hand, denotes the right of a manager to decide and command. For example, a manager has a right to assign tasks to subordinates and expect and require satisfactory performance from them. But the manager may not have the means (or power) available to enforce this right. Thus, whether a manager can enforce his rights is a question of power. Similarly, there may be a situation where a person has a power to do something, but lacks authority to do it. Such situations may cause conflicts in organizations. Therefore, for organizational stability, power and right to do things should be equated. "When power and authority for a given person or position are roughly equated, we have a condition we may call legitimate power".

#### Student Activity 1

1. Recall some occasions in which you have exercised the different forms of power: legitimate, coercive, reward, expert, referent, and information.
  - a. Which forms of power do you use most frequently?
  - b. What prompts you to use those forms of power?
  - c. Which forms of power do you rarely or never use?
  - d. What keeps you from using some forms of power?

### Sources of Power

John French and Bertram Raven have identified five sources or bases of power which may occur at all levels of the organization. These are discussed below:

- (i) **Reward Power:** It is based on the influencer having the ability to reward the influencee for carrying out orders. The extent of reward power depends upon the extent to which one has control over rewards that are valued by another.
- (ii) **Coercive Power:** It is based on the formal rights one receives as a result of holding a position in an organization. It may also be called 'positional power' because of authority inherent in the position. It exists when an influencee acknowledges that the influencer is lawfully entitled to exert influence. It is also implied that the influencee has an obligation to accept this power.
- (iii) **Legitimate Power:** It is based on the formal rights one receives as a result of holding a position in an organization. It may also be called 'positional power' because of authority inherent in the position. It exists when an influencee acknowledges that the influencer is lawfully entitled to exert influence. It is also implied that the influencee has an obligation to accept this power.
- (iv) **Expert Power:** It is based on the perception or belief that the influencer has some relevant expertise or special knowledge that others do not have. For example, a doctor has expert power on his patients. It is a type of personal power.
- (v) **Referent Power:** It is based on the influencee's desire to identify with or imitate the behaviour of the influencer. It develops out of others' admiration for a person and their desire to model their attitudes and behaviour after that person. For example, a manager will have referent power over the subordinates if they are motivated to emulate his work habits.

These are potential sources of power only. Possession of some or all of them does not guarantee the ability to influence particular individuals in specific ways. The role of the influencee in accepting or rejecting the attempted influence is very important. It may also be noted that, normally, each of the five power bases is potentially inherent in a manager's position.

Some generalizations about the use of power and effectiveness of various bases of power are given below:

1. There is no evidence of power unless it is exercised. The purpose of power is influence over others for getting certain things done.
2. Power is stronger than influence. It is the ability to bring about potential acts by commanding or exerting influence. But influence is a psychological force. In exerting influence, one person tries to influence the behaviour of another.
3. The effect of power is reduced when it is exercised outside its perceived limits.
4. The stronger the power base, the greater is the power. The strongest power base is legitimacy (or formal authority) and the weakest is coercion.
5. A person difficult to be replaced has more power than others. If a low ranking employee has more knowledge than his superiors, he is likely to have more personal power.

### **Distinction between Authority and Power**

The terms 'authority' and 'power' are generally used interchangeably, but there is a clear-cut distinction between the two as discussed below:

- (i) **Nature:** Authority is the right to command; power is the ability to exercise influence. Authority usually resides in the position organization, but power is

exercised by the person. Authority includes the right to command which has been institutionalized. Thus, authority is always positional and legitimate and is conferred on the position. But power is not institutional, rather it is personal. It is acquired by people in various ways and exercised upon others. It is acquired through political means or by having certain personal attributes.

- (ii) **Association with Structure:** Authority of a person is associated with the position in the formal organization. It increases as one goes up the organizational hierarchy. But it need not necessarily be accompanied by more power. In actual practice, the power centres may be located at the lower levels in the organization. Thus, one cannot get any idea of power centres in an organization by merely looking at its organization chart.
- (iii) **Relationship:** The structure of an organization merely shows its authority relationships. In practice, these relationships are modified by power politics in the organization. Some individuals may have more power and less authority or more authority and less power. It is the operating mechanism of the organization which is relevant for studying organizational behaviour.
- (iv) **Flow:** Authority is a downward flowing concept whereas power flows in all directions. Authority can be delegated to the lower levels in the organization. The lower we go down the hierarchy, the lesser is the authority. But it is not so in case of power which has been defined as the ability or capacity to influence the behaviour of others. If a worker succeeds to influence the behaviour of a departmental manager, it is implied that the worker has exercised power over the departmental manager.
- (v) **Pervasiveness:** Authority rests with important positions in the organization whereas power is all-pervasive. For instance, an informal leader may be more powerful than even a departmental head.
- (vi) **Responsibility:** The extent of authority is limited to the amount of responsibility. Authority and responsibility are coextensive and balance each other. But in case of power, there is no such balancing factor. Persons wielding greater power may have only limited responsibility.
- (vii) **Formal/Informal:** Authority is inherent in official positions in the organization and so it is always formal. But power can be both formal and informal. Sometimes, informal power of a person exercises greater influence in the organization than is formal authority which is also called legitimate power.

### **Types of Authority Relationships**

Modern organizations make considerable use of line, staff, functional and committee authority and various combinations thereof. All the four types can be found in almost every big organization. The organization patterns that accompany the four types of authority have already been discussed in this chapter. Now we shall discuss the nature of various types of authority.

#### **Line Authority**

Line authority refers to those positions and elements of the organization which have responsibility and authority and are accountable for accomplishment of primary objectives. "Line authority, the basic authority in an organization, is the ultimate authority to command, act, decide, approve or disapprove - directly or indirectly - all the activities of the organization. It is the authority to direct the work of others and to

require them to conform to decisions, plans, policies, systems, procedures and goals. Line authority is the heart of the relationship between superiors and subordinates”.

Line elements provide authority to decide and direct and a central means for flow of communication through a scalar chain of authority. Line officials are in the chain of command from the highest executive to the lowest position in the organization as shown in Figure 2. Each successive manager exercise direct line authority over his subordinates. However, line authority is not absolute. Managers are responsible for how they exercise authority and for its consequences. They must use judgement and discretion and stay within the limits of their delegated authority. They must apply authority reasonably to the performance of tasks and the proper execution of organizational policies. It should be remembered that the primary purpose of line authority is to ensure effective functioning of the organization. It does so in the following ways:

- (i) Line authority acts as a chain of command from chief executive to lower level workers. It also provides for the channel of communication.
- (ii) It provides the basic decisions required for operating the enterprise.
- (iii) It makes the leadership process effective by establishing authentic channels of communication.
- (iv) It provides points of reference for the approval or rejection of proposals.
- (v) It serves as a means of control by setting limits to the scope of managerial actions.

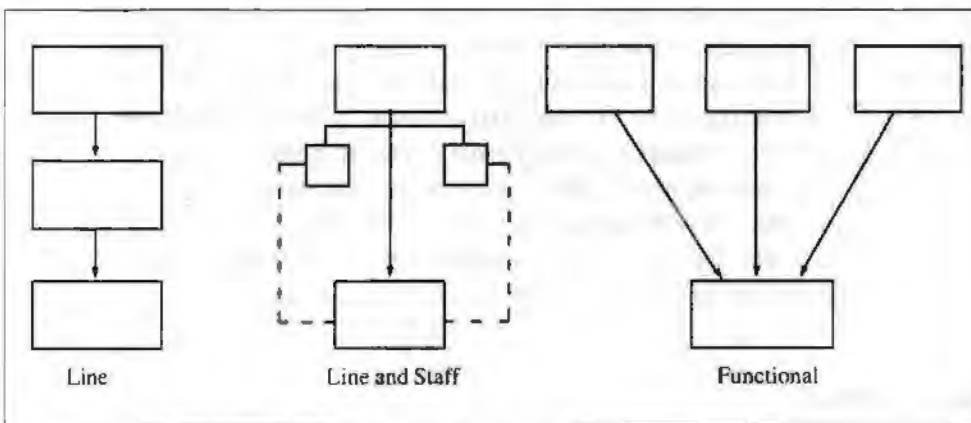

Figure 2: Types of authority relationships

### Staff Authority

Staff refers to those elements which have responsibility and authority for providing advice and services to line in attainment of objectives. Fayol described staff as an adjunct reinforcement and a sort of extension of the manager’s personality. Line managers make the salient decisions by exercising command authority, whereas staff officials advise and counsel, with no authority to command but within their own staff chain of command. According to McFarland, “Staff authority is best defined as authority whose scope is limited, by the absence of the right to direct or command, to such auxiliary and facilitating activities as planning, recommending, advising or assisting”.

The nature of staff authority is advisory as shown by broken lines in Figures 2 and 3. The use of staff to assist line came about because of the need to provide special



counsel and assistance to the line manager who is unable to carry out the demands of his position. Line authority alone becomes inadequate for large organizations whose managers face an increasing number of problems that can better be handled by staff specialists.

The basic criterion for distinguishing between line and staff functions is the degree of closeness of the function to the primary objectives of the organization. Basic activities such as production, finance and marketing are usually line departments. Activities such as industrial engineering and costing, which consist mainly of assistance, advice or services cutting across several units, are general set up as staff departments. However, the indirect relationship of staff to primary objectives does not necessarily mean any lack of importance.

Pure staff authority has no right to command except within the staff department itself. Staff managers cannot issue orders. They work by planning, thinking, studying, informing, recommending, persuading and suggesting. Thus, staff orientation is different from the line orientation which is concerned directly with the primary objectives of the enterprise. Staff men relieve the line men of the burden of details, often technical, which would otherwise be handled less ably. Staff managers possess specialized knowledge and skills. They can provide better solutions to organizational problems in their areas.

In practice, the distinction between line and staff gets blurred. Staff advice or service may be accepted by others much the same as the line authority is. Staff managers may make command decisions when line managers fail to act or decide. Moreover, staff managers may be delegated authority to command on certain matters by the line managers. The demarcation between line and staff may be possible during the initial stages of the organization; but when it grows, its functions become more and more complex and the demarcation between line and staff becomes progressively fuzzier. Another basic criticism of the line and staff concepts is that the distinction between them is based on the assumption that organizational activities can be segregated on the basis of their contribution in achieving the organizational goals. But all activities, whatever name they may be given, collectively contribute to the achievement of organizational goals. The segregation of expert knowledge from actual performance of the job is unwise and uncalled for in the present era of vast technological developments.

### Types of Staff

Staff may be divided into the following three categories:

- (a) **Personal Staff:** It refers to the positions created to help a manager in carrying out those parts of his responsibilities which he cannot or does not want to delegate to others. Personal staff is required by top managers because their responsibilities grow beyond their personal capacities. For instance, a general manager of a company may have a personal secretary to help him in carrying out his responsibilities.
- (b) **Specialized Staff:** It counsels, advises and helps all line and other staff elements in the organization. It consists of specialists in different areas like accounting, quality control, personnel, public relations, etc. Staff specialists generally provide both advice and service to the line departments of the organization.
- (c) **General Staff:** It consists of a group of experts in different areas who are attached to the central office of the organization. It is generally employed to provide advice on certain matters to the top management.



## Functional Authority

Functional authority occupies a midway position between line and staff authority. It is means of putting the staff specialists in top positions for the entire enterprise and it confers upon the holders a limited power to command over the people of their departments concerning their function. For empowering the persons in charge of various functional areas to maintain the quality and uniformity of the functions throughout the enterprise, functional authority is granted to them in addition to the line authority over his department and over the activities of other departments that pertain to his functional area.

Functional authority is subordinate to line authority and is a way of putting specialists to work in the organization. Functional authority differs from line authority in that its right to command is limited to a particular specialized area. It differs from staff authority in that functional authority confers upon its holders the right to command in matters pertaining to that function. The greatest weakness of functional authority is that it may subject subordinates to the conflict of multiple supervision. However, this multiplicity may not always be undesirable. Whenever functional authority is granted to some individual, it should be properly evaluated, whenever conflict arises. The scope of functional authority is limited. Suppose, for example, that the production control department found that supervisors were changing routing and scheduling of materials at will. The production control manager could issue final orders of routing and scheduling. Thus, functional authority assures that production policies would be properly followed in each workshop.

## Use of line, Staff and Functional Authority

An organization may follow a structure which makes use of line, staff and functional authority as shown in Figure 3. The Human Resources and Finance Managers act as staff advisors to the Managing Director.

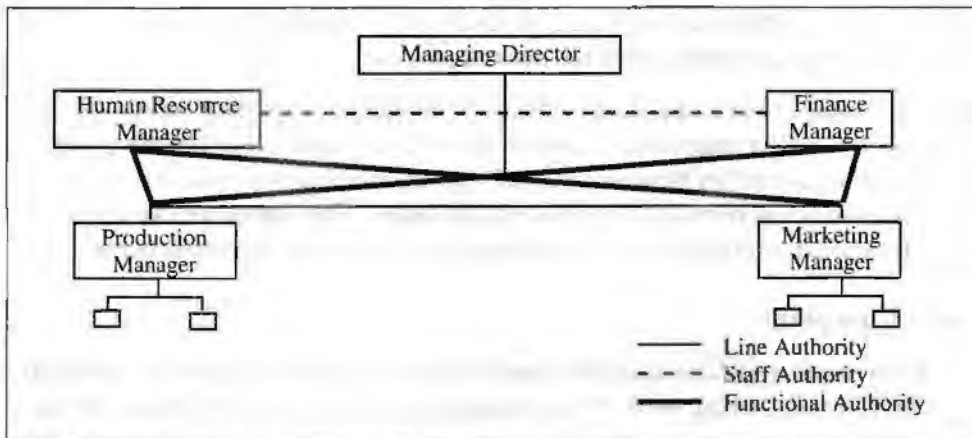

Figure 3: Line, Staff and Functional relationships in organization structure

But as far as production and marketing departments are concerned, they act as functional managers. The Managing Director has line authority over the Production and Marketing Managers represented by a bold vertical line. Similarly, Production and Marketing Managers have line authority over their respective subordinates.

## Conflict Between Line And Staff

Line and staff concept is based on the assumption that they should support each other and work unitedly for the achievement of enterprise objectives. But an unfortunate

Comparison of Line, Line & Staff and Functional Authority			
Basis	Line	Line & Staff	Functional
1. Nature	The line authority follows the principle of scalar chain. It flows from top to bottom in	The staff have advisory role. They don't have authority to get their advice accepted.	The functional authority is restricted to a function only and it flows diagonally. The line, functional manager has authority over his function wherever it is performed.
2. Specialisation	Line managers are generalists.	Staff officials are specialists in their respective areas.	Functional managers are specialists in their respective areas.
3. Unity of Command	There is unity of command. Each subordinate receives orders from his boss only.	Unity of command is observed to a great extent. The staff officials cannot give orders to the people in the chain of command.	Unity of command is not followed as each subordinate gets instructions from his line boss and the functional bosses.
4. Discipline	There is strict discipline.	More or less, there is strict discipline.	There is loose discipline because of multiplicity of command by various functional experts.
5. Suitability	It is suitable for small scale operations.	It is suitable for medium-scale operations.	It is suitable for large scale operations, where expert knowledge in certain fields is essential.
6. Economy	It is economical because a few line executives are required.	It is little costlier because of use of staff specialist alongwith line executives.	It is very costly because of placement of functional experts as heads of various departments.

result of this concept is the creation of status problems in the organization. Line members view themselves as important and first class members of the organization because they directly accomplish the objectives of the enterprise. And the staff members are often treated as second class members. The line members ignore staff advice and they often act according to their own thinking. Thus, line and staff arrangement has failed to achieve the desired purpose.

The major source of line and staff conflicts is the difference in their viewpoints and perceptions. Conflict arises when either of them fails to appreciate the viewpoints of the other. When a conflict between line and staff arises, each party tries to explain the causes of conflict in terms of behaviour of the other. The important causes of line and staff conflict as reported by line and staff executives are discussed below.

### Line's Viewpoint

1. **Undermining of Line Authority:** Staff officers encroach upon the line authority. They interfere in the work of line managers and try to tell them how to do their work. They undermine the role of line executives by trying to impose their ideas on the line executives.
2. **Academic Approach of Staff:** Staff specialists are too academic and do not understand the practical problems of the organization. Their ideas are often unrealistic and impracticable. They are armchair theoreticians living in their ivory towers and totally cut off from the realities of the situation. They are not well acquainted with operating problems of the company. They unnecessarily create paper work for the line managers.
3. **Lack of Accountability:** The staff men are not directly accountable for any result; they are generally overzealous and recommend a course of action which

is not practicable. It is also said that because of lack of accountability, the staff officials often given unsound advice.

4. **Limited Outlook of Staff:** The staff often thinks in a vacuum and fails to see the 'big picture' of the organization. Line is loyal to the overall objectives of the organization; staff is loyal to a narrow area of speciality. That is why, staff fails to relate its ideas to the organizational objectives.
5. **Stealing of Credit:** The staff specialists have the tendency to take credit for the decisions which prove successful and lay the blame on the line men in case the decisions do not prove successful. They are overambitious and want power without responsibility. Staff people usually have a strategic advantage because they are closer to the top executive and have more frequent access to him.

### Staff's Viewpoint

1. **Ignoring the Staff:** Line managers generally do not make a proper use of the services of the staff specialists. Their advice is often ignored. Sometimes, staff advice is sought only as a last resort as line executive feels that asking for the advice is admitting defeat.
2. **Resistance to New Ideas:** Line managers generally resist new ideas as they consider staff as a threat to their status and authority. They sabotage ideas and programmes of staff. Line managers do not 'look beyond their nose'. They are short-sighted and follow a 'wait and see' policy.
3. **Lack of Enough Authority:** A general complaint from the staff side is the lack of proper authority. Staff specialists feel that if they have arrived at the best solution to a problem, they should be able to put into action. But due to lack of authority, they are unable to do so.

### Suggestions for Improving Line-Staff Relationships

The conflict between line and staff is not in the interest of the organization and therefore, efforts should be made to resolve it. The following steps may be suggested to resolve conflict between line and staff:

**Box 3**

Line and Staff Conflict	
Line Managers	Staff Specialists
1. Are generalists having wide knowledge and experience of different areas of business.	1. Are specialists in particular areas and lack the experience of different areas of business.
2. Are ultimately responsible for decisions.	2. Lack authority to implement decisions.
3. Have short and long-range orientations.	3. Have long-range orientation.
4. Want simple, easy to use solutions.	4. Provide Scientific solutions.
5. Are action-oriented, they want to solve the problem now.	5. Are thought-oriented; they want to examine the problem in depth and solve it later.
6. Like to solve problems on the basis of experience, intuition and "gut feeling".	6. Like to solve problem using the latest and most sophisticated techniques.
7. Consider staff as theoreticians and irresponsible.	7. Consider line as over-confident and short-sighted.



1. The line of demarcation between line and staff authority should be clear. It must be understood by line and staff men that line has the ultimate responsibility for the implementation of the decisions and staff is responsible only for providing advice and service to the line departments.
2. Qualified and trained personal should be placed on staff positions. They must have the ability to explain their advice in concrete terms to the line managers and to convince them about the practicability of their advice.
3. The top management should take steps to educate the staff to be aware of line attitudes and sensitivities and to educate the line of the value of specialized skills of experts.
4. Line managers must give due consideration and serious thought on the advice of experts before taking the final decision. In case they do not accept the staff advice, sufficient reasons should be given for doing so.
5. Line and staff people should operate in terms of policies and objectives of the whole organization. They should try to understand as to how they can contribute to these objectives. The staff official should have the tolerance power because his ideas are likely to be resisted in the initial stages.
6. The staff men should appreciate the difficulties in implementing the new ideas. They should not consider it as a prestige issue if some of their suggestions are not implemented. They should understand that the ultimate accountability is that of the line managers.

### **Is Line and Staff an Obsolete Concept**

The division of organizational relationships on the basis of line and staff produces more conflicts than cooperation as it is very difficult, in practice, to demarcate the limits of their authority. Some writers, particularly G.G. Fisch and H.H. Logan, have argued that the concept of line and staff is of merely of academic interest and it has no practical applicability. But the concept of line and staff has become so popular in management literature that it is not so easy to eliminate it through it may not have any practical relevance. According to Logan; "The concept that all functions or departments of a business enterprise are either line or staff is now so firmly entrenched in management theory that any attempt to dislodge it may well seem doomed to failure. Yet it is certainly pertinent to ask, how applicable to business today is this seemingly immutable principle of organization".

Logan further emphasizes that demarcation between line and staff may be possible at the initial stage of the organization, but when it grows, its functions become more and more complex, the demarcation between line and staff functions becomes progressively fuzzier until, in large organizations, it is no longer possible to state unequivocally just who is directly engaged in furthering its objectives and who is not.

The basic criticism of the line and staff concept is that it is based on the assumption that organizational activities can be segregated on the basis of their contribution to the achievement of organizational goals. In the traditional way of classifying line and staff, production and marketing functions are treated predominantly line departments. There are many functional departments whose activities cannot be reconciled with the proposition that production and marketing are the only segments of the organization directly concerned with furthering its objectives. All activities, whatever name they may be given, collectively contribute to the achievement of objectives. The segregation of expert knowledge from the actual performance of the job is unwise.

It appears that line and staff distinction is based on the assumption that those who are good at thinking and planning are not good in doing and vice versa. This assumption has also gone wrong in the complex industrial world. In practice, three types of authority, namely, line, staff and functional, are not granted to three categories of persons. One person may be granted all the three types of authorities simultaneously. In order to avoid line and staff conflicts, it is essential to clearly define the various authority relationships. This will help in improving the working of the organization by avoiding the gap in and overlapping of authority and responsibility.

## Keywords

**Authority:** Authority is the right to order or command and is delegated from the supervisor to the subordinate to discharge his responsibilities.

**Responsibility:** Means the work or duties assigned to a person by virtue of his position in the organization.

**Accountability:** It is the obligation to carry out responsibility and exercise authority in terms of performance standards.

## Review Questions

1. (a) Define and distinguish between line, staff and functional relationships.  
(b) Write an explanatory note on line and staff conflict.
2. "Staff is supposed to be subsidiary to line, but in reality staff is more influential and powerful than line". Do you agree? Give reasons in support of your answer.
3. "The line manager's orientations differ considerably from those of expert staff advisers". Why? Suggest measures to resolve the conflicts between line and staff.
4. The chief executive of a large manufacturing enterprise is upset over frequent clashes and continuing conflicts between the production department and the personnel department. The enterprise is organised on line and staff pattern. What can be the possible causes of this conflict and what steps can be taken to reduce and overcome it?

## Further Readings

Allen, Louis A., *Management and Organization*, McGraw-Hill.

Allen, Louis A., *Management and Organization*, McGraw-Hill Kogakusha Ltd.

Amitai Etzioni, *Modern Organizations*, Prentice-Hall of India, New Delhi.

Barnard, Chester I., *The Functions of the Executive*, Harvard University Press, Cambridge.

Brech, F.E.L. (ed), *The Principles of Practice of Management*. Longmans, Green & Co.

Chester I. Barnard, *The Functions of the Executive*, Cambridge Harvard University Press.

Dalton E. McFarland, *Management: Foundations and Practices*, New York, Macmillan.

Fred Luthans, *Organizational Behavior*, McGraw-Hill, New York.